

# Supplement to Instruction Manual

HL 1004 RF-PLUS EX

 II 2G IIB T4

 II 2D T4

For operation in  
explosive atmospheres

- zone 1 (Gas)

- zone 21 (Dust)

Characterised by the product mark

 Zone 1

 Zone 21

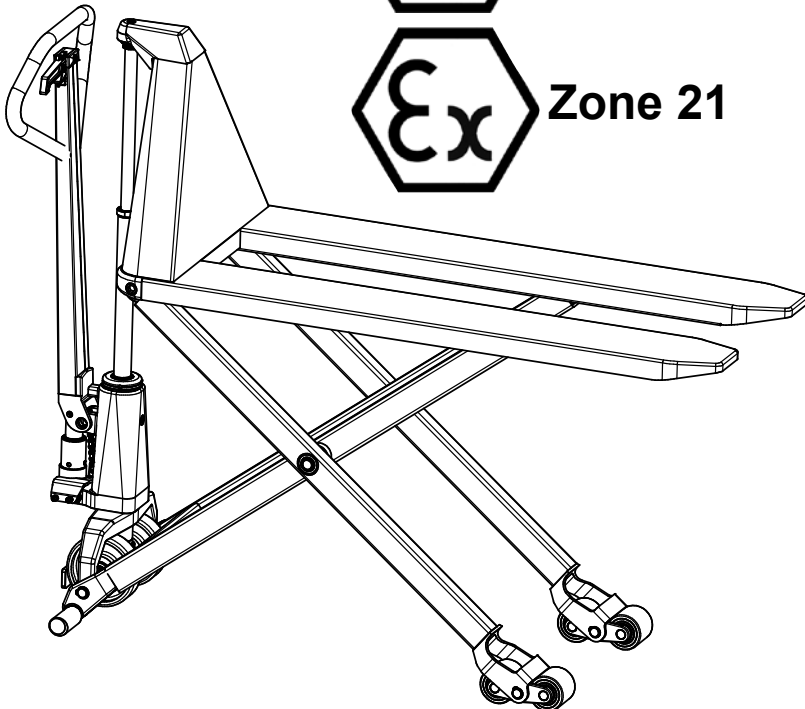

This supplement for the instruction manual of the basic product indicates that the construction of the product is in accordance with the safety precautions and that the product is suited for operation in explosive atmospheres - zone 1, generated by gases, vapours or mist in apparatus group IIB and in temperature class T4.

Or - zone 21 concerning dust in the temperature class T4.

The explosion proved construction is characterised by the following product mark:

 II 2G IIB T4 (Gas)

 II 2D T4 (Dust)

**Safety precautions:**

Dust, dirt, painting, acid, washout, overload and impacts can lead to a reduction or a total breaking of the earthing of electric/electrostatic energy. The permanent compliance with the safety-related and technical stipulations, such as e.g. control of the wheel(s) with conductance concerning the above functional disturbances, is the responsibility of the user exclusively.

**Additional wheels:**

The explosion proved highlifter will have at least one anti-static wheel with a separate item no.

When reordering an anti-static wheel, please state product type and whether the wheel is used as steering or fork wheel.



## EU DECLARATION OF CONFORMANCE

Manufacturer: **Logitrans A/S**  
**Hillerupvej 35**  
**DK-6760 Ribe**  
**Denmark**



It is hereby declared that:

Machine: Product group: Highlifters - zone 1 and - zone 21

Type: HL 1004 RF-PLUS EX  **II 2G IIB T4 (Gas)**  
 **II 2D T4 (Dust)**

Type approval: **PTB 01 ATEX 4143 X**  
**Logitrans ATEX D129 (Dust)**

Year of manufacture/  
Serial No.:

- a)** Has been manufactured in conformance with the stipulations of the
- **Directive no. 2006/42/EC**
  - **ATEX Directive no. 94/9/EC**
- b)** Has been manufactured in conformance with the stipulations of the standards:
- **EN 1757-4** • **EN 1755**
  - **EN 50014** • **EN 1127-1**

Name: **Erling Pedersen**

Position: **Product manager**

Company: **Logitrans A/S**

Signature: 

Product type declaration of:  
01.10.2013

Distributor:

D100-5

The highlifter is further characterised by the following product mark:

When inserting and withdrawing into and out of pallets, avoid dragging the highlifter against sharp edges.

### **Periodic safety inspection**

Safety inspection should be performed by the supplier or other qualified persons at least once each year, unless local regulations state otherwise.

Such inspection shall be performed in accordance with the instruction manual. Test instructions and test forms are available from the distributor.