

# Instruction Manual

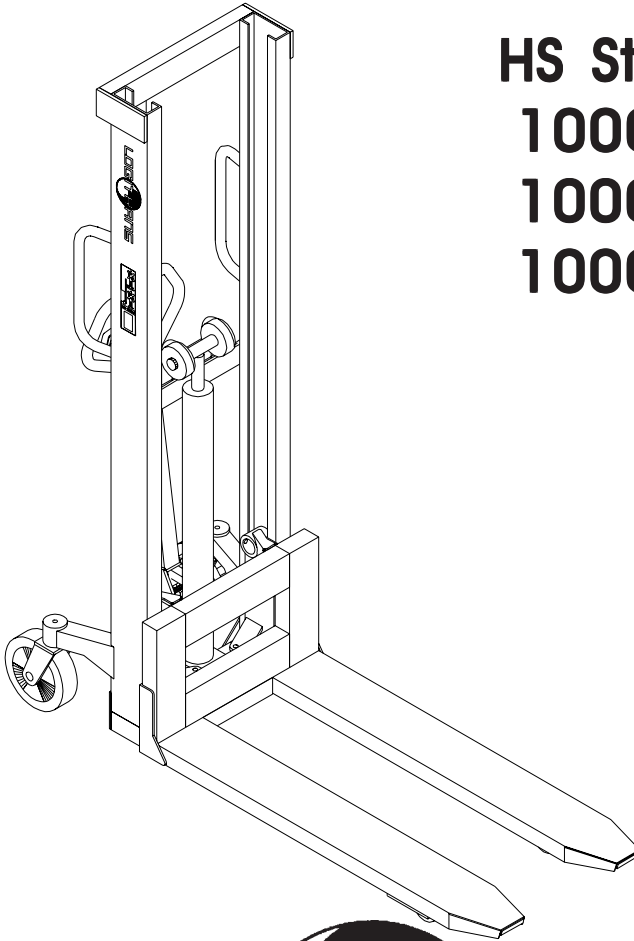

**HS Stainless**  
**1000/1200**  
**1000/1400**  
**1000/1600**

**LOGITRANS**

[WWW.LOGITRANS.COM](http://WWW.LOGITRANS.COM)

## EU DECLARATION OF CONFORMANCE

Manufacturer: **Logitrans A/S**  
**Hillerupvej 35**  
**DK-6760 Ribe**  
**Denmark**

It is hereby declared that:

Machine:           Product group:           Stackers

                          Type:                           HS 1000 RF

                          Year of manufacture/  
                          Serial No.:                   

- a)** Has been manufactured in conformance with the stipulations of the
- **COUNCIL DIRECTIVE no. 98/37/EC**
- b)** Has been manufactured in conformance with the stipulations of the standard:
- **EN-1757-1**

Name:           **Erling Pedersen**

Position:       **Product manager**

Company:       **Logitrans A/S**

Signature:      

Product type declaration of:  
15.11.1999

Distributor:

# 1.0 Before the first lift...

The **Logitrans** Stacker is manufactured in accordance with safety directives.

Among the subjects dealt with in this **Instruction Manual** are:

- *Proper application*
- *Physical limitations of the product*
- *Risks with improper use*

**- Therefore please read this Instruction Manual carefully!**

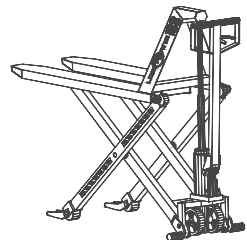
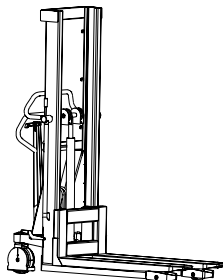
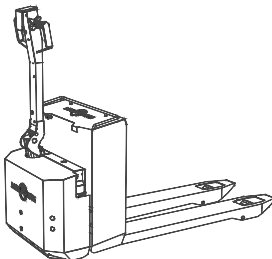
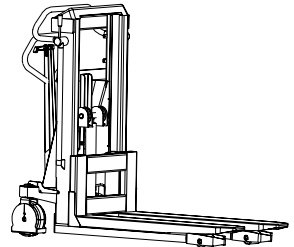
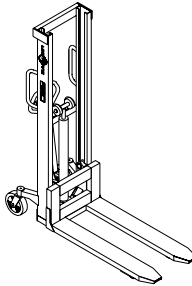
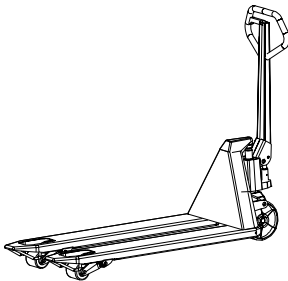

# 2.0 How to operate the stacker

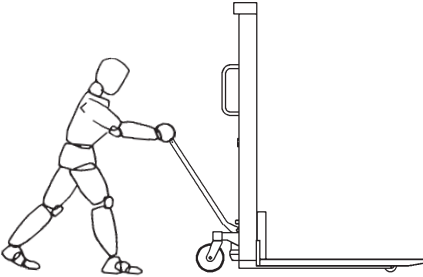

## STACKER APPLICATION - PALLET HANDLING -

For proper operation,  
stand behind the handle.

Push/pull - pump

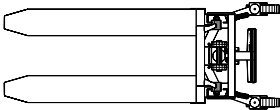
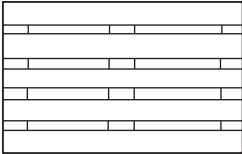
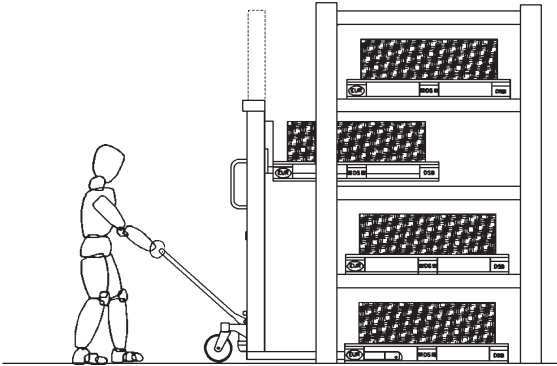

HS

## 2.1 The three release lever positions

1. Quick Lift
2. Normal Lift
3. Lowering

### 2.1.1 Quick Lift

0 - ca. 300 kg

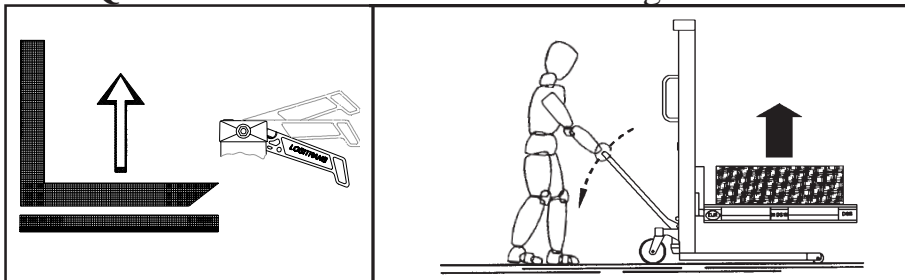

### 2.1.2 Normal Lift

ca. 300 - 1000 kg

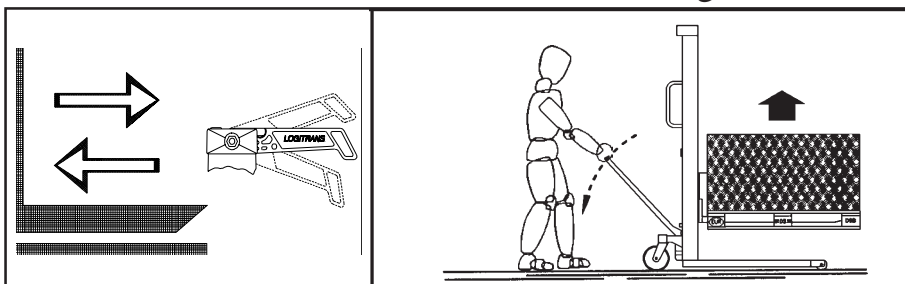

### 2.1.3 Lowering

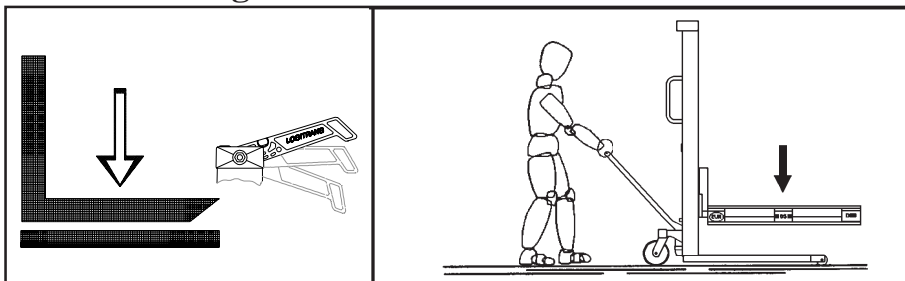



## 3.0 Optimum safety

### 3.1 Avoid overloads

The maximum load must not be exceeded. Remember, the stacker is designed for evenly distributed load, - goods on pallets etc. If the forks are point-loaded on one side there is a risk of bending.

### 3.2 Avoid offset loads

The load must be distributed **evenly** on pallets or similar, - with a maximum distance of 600 mm between centre of gravity and mast front. A greater distance reduces the level of safety and increases the risk of toppling.

Goods on pallets, etc. must be properly secured so that they cannot fall off during transport, when the truck is lifted, or when the truck must remain lifted for a time.

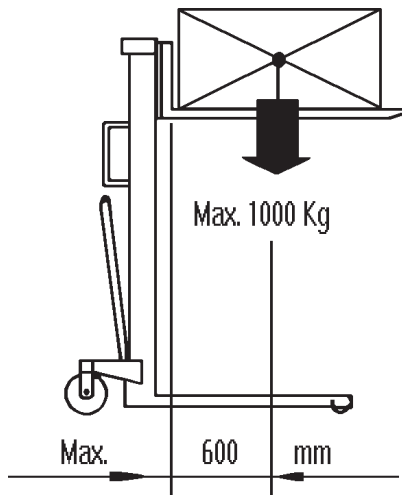

### 3.3 Safety valve/pressure relief valve

The pressure relief valve on the stacker is factory-set for the maximum design load (**1000 kg**). The setting protects the truck from overload so that it cannot be damaged by the inadvertent lifting of too high a load. - If the pressure relief valve is defective, replace the entire valve insert. When a valve insert is ordered from a distributor, replacement instructions accompany the replacement part.



### 3.4 Driving loaded

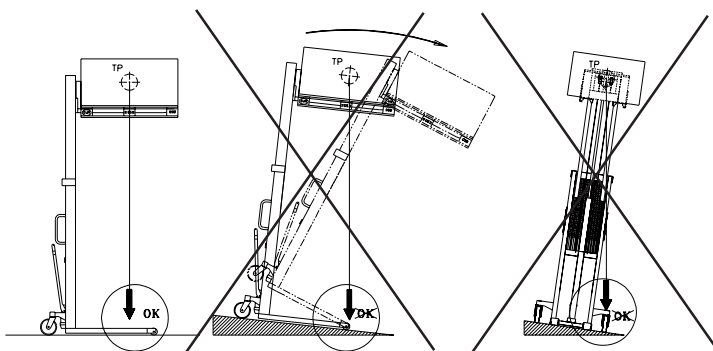

The stacker is designed for use on even and level floor. During transport the forks shall be raised as little as possible. Transport with raised forks should be made over the shortest possible distances and at low speed.

### 3.5 Emergency braking

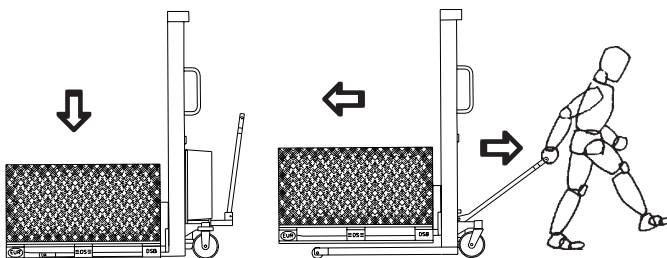
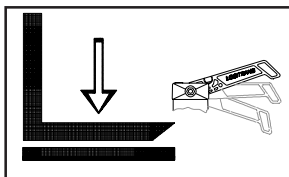

If the wish is to use the load as a brake to prevent the stacker from running away, quickly pull the release lever up to lower the load to the ground.



## ATTENTION MOVING PARTS

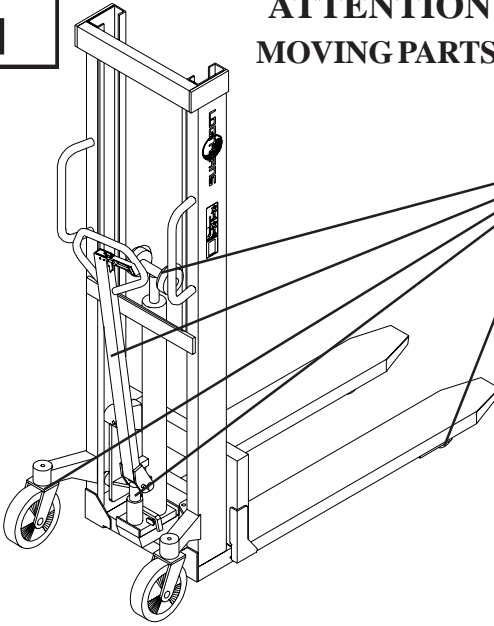

## Safety regulations

- Never walk under a raised load!
- Before lowering the forks, make certain that no foreign elements can hinder the free lowering of the forks.
- The stacker is designed for use on even and level floor.
- During transport the forks shall be raised as little as possible.
- Transport with raised forks should be made over the shortest possible distances and at low speed.
- Check that the chains lift equally. They shall be equally tight when the forks are loaded.
- Chains and chain bolts must not be damaged. Chains that have become permanently stretched (max. 2% of original length) must be scrapped.



## 4.0 Long live the stacker

Regular inspection and the replacement of worn or defective parts in good time will prolong the life of the pallet truck.

"Prevention is better than repair", therefore ensure:

- Correct usage
- Regular cleaning
- Oil changes at the correct intervals
- Periodic safety inspection

### 4.1 Lubrication and oil change

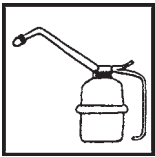

All ball bearings are lubricated with a lubricating grease for the food industry, and all moving parts are treated with a grease for the food industry. The hydraulic system is filled with hydraulic oil of viscosity class ISO VG15 and viscosity index 372 (TEXACO Aircraft 15). The oil is suitable for use in the temperature range -40°C to +50°C.

**The hydraulic oil must be changed every other year.**

### 4.2 Oil change

#### **Draining:**

The pallet truck has to be in lowered position.

Tip the truck over on its side and remove the plug No. 120.

Oil now runs out of the filling hole.

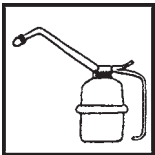

#### **Filling:**

Raise the truck again and pour about 0.25 litres of hydraulic oil.

The oil must be on level with the filling hole.

Pump the truck in top position.

Replace plug No. 120 again.

## 4.3 Replacement of valve insert(s)

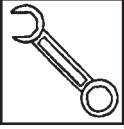

If all fault remedy possibilities (See middle pages) have been tried without satisfactory results the entire valve insert must be replaced.

### Low-pressure valve insert 160094:

The insert contains both the valve control system and a pressure relief valve.

### High-pressure valve insert 400672E:

The insert is sealed and cannot be activated externally.

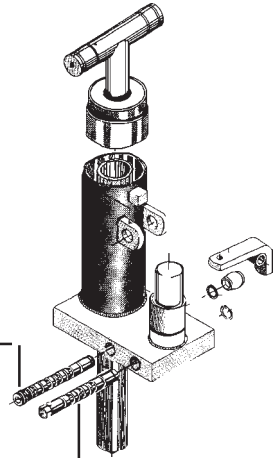

When a new valve insert is ordered from a distributor, **replacement instructions** accompany the replacement part. Therefore order before replacing!

After replacement, adjust the oil quantity in the tank, as described under **Oil change** (point 4.2). Then **bleed** the system (point 4.6).

## 4.4 Seal leakage



Locate the point at which oil leakage appears and then replace defective seals. (See spare parts list).

## 4.5 Valve cone does not seal completely



Pump quickly a few times so that oil quickly flows over the valve cone (best with a small load on the forks).

If this does not solve the problem, the valve insert must be replaced by a new one.

(Replacement instructions accompany the new valve insert).

## 4.6 Bleeding the hydraulic system

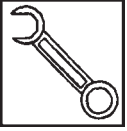

The pump will not operate throughout its whole pump stroke if there is air in the hydraulic system.

- The system can be bled as follows:

1. Pump the forks up to the top and sink them quickly or
2. loosen screw No. 130 and press the handle down until no more air comes out of the screwhole.
  - The handle must only be pressed **down** when screw No. 130 has been loosened. Tighten the screw again before raising the handle.

If the hydraulic system contains only a small amount of air, it will be bled automatically when the forks with load are pumped up to top position.

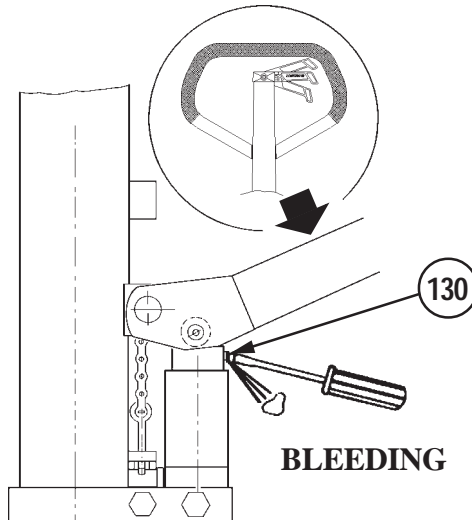

## 4.7 Cleaning

When cleaning the stacker, do not direct the jet onto bearings and seals. Otherwise the grease will be washed out and the life of the equipment shortened.

## 4.8 Adjustments of lowering mechanism



The lowering mechanism is adjusted correctly if:

- Quick lift = when the release lever is in bottom position (pos. 1)
- Normal lift = when the locking pawl of the release lever is engaged (pos. 2)

**If this is not the case, adjust as follows:**

1. Place the release lever in normal position - locking pawl engaged, (pos. 2)
2. Press the handle down (pos. P)
3. Tighten in this position the nut pos. 113, as much as possible - without the forks beginning to move down.

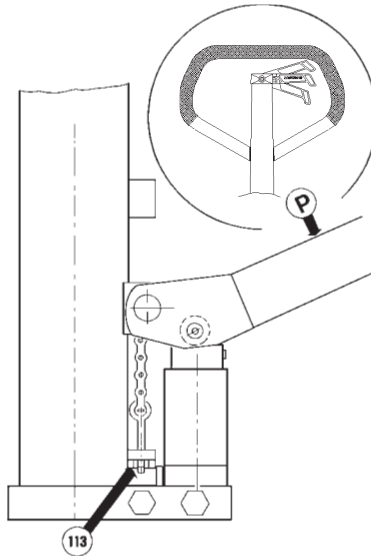

## 4.9 Adjustment of lifting chain



The chains shall be adjusted so that they lift equally.

- Shall be equally tight!

Adjustment are made on nuts, pos. 18  
(nut M12, key width 19 mm).

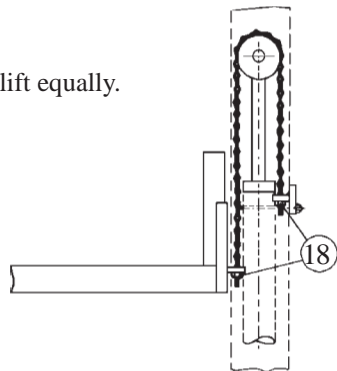

## 4.10 Fork adjustment

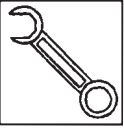

Two rollers on the fork bracket are mounted on eccentric pins so that they can be adjusted.

### Adjustment:

1. Loosen screws pos. 91 (5 mm).
2. Pin pos. 56 can now be turned to give the necessary adjustment.(8 mm)
3. To ensure the same load on all rollers, adjustment must be made on both sides.

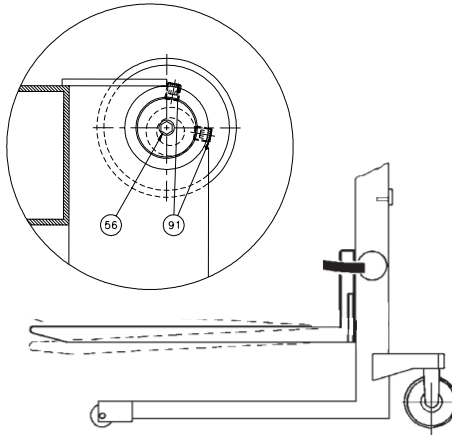

**Max 1000kg**

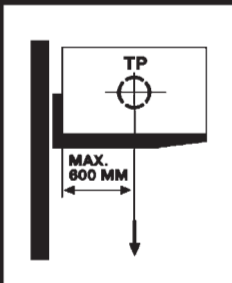

## Marking

The mast lifting capacity and the corresponding centre of gravity distance are given by the pictogram on the side of the mast.

The lifting capacity of the mast is the same as the max. lifting capacity of the product.

Max. lifting capacity is set on the safety valve in the product.

# 5.0 The advantages of stainless

## 5.1 Corrosion in HS Stainless

Details are contained in the spare parts lists.

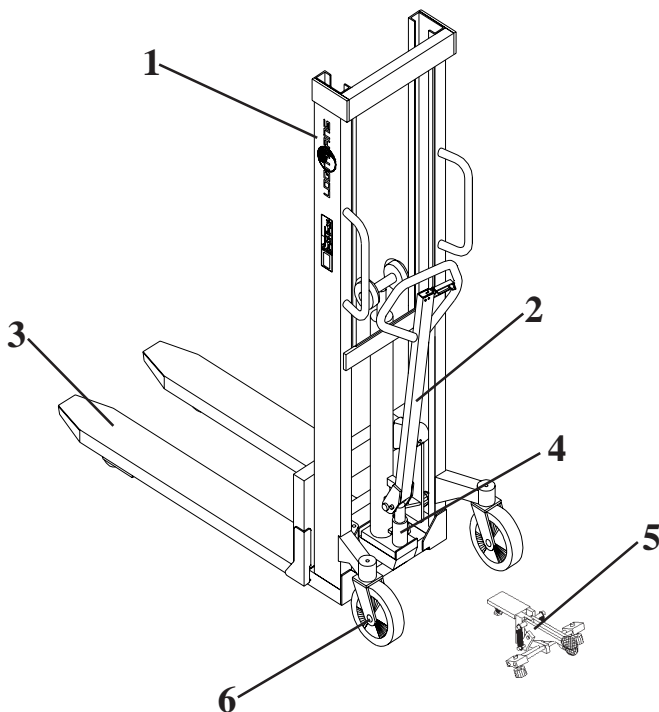

- 1. Chassis
- 2. Handle
- 3. Fork bracket
- 4. Pump (1)
- 5. Brake
- 6. Shafts

A	B	C	D
	X		
	X		
X			
			X
			X
X			

## Material code

<b>A</b>	Acid-resistant steel AISI 316
<b>B</b>	Stainless steel AISI 303/304
<b>C</b>	Hot-dip galvanised - coating thickness: min. 50 µm
<b>D</b>	Electrogalvanised + yellow chromated - coating thickness: 6-10 µm. - This surface treatment has good properties in respect of wear, water and chemical resistance. However, it is important to be aware that if certain parts are subjected to shock and impact the coating can crack and thus allow corrosive substances to affect base materials.

- (1) The pump is not made of stainless material. The pump housing is surface treated (D).  
Special attention is drawn to the cylinder in which the piston rod is stainless.  
Under certain circumstances, corrosion can appear on parts of the pump.

## 5.2 Warranty for HS Stainless

Stain in the telescopic cylinder or pump and tarnishing on the highlifter because of the environment in which it is used or the way it is cleaned are not covered by warranty. See point 7.4 "Warranty conditions".

# 6.0 Fault location key

When the STACKER is used every day, adjustments and the replacement of worn parts might be necessary.

BEFORE ASKING THE DISTRIBUTOR FOR ASSISTANCE...

...TRY THE FAULT LOCATION KEY!

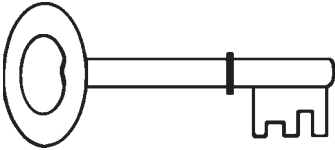

## SYMPTOMS AND SIGNS

- A** Forks move up and down with pump strokes-----
- B** Truck does not lift to maximum height-----
- C** The load is difficult to pump with the handle in its normal position-----
- D** The forks do not lift quickly when the handle is in its Quick position-----
- E** Forks cannot be lowered-----
- F** The forks sink after they have been raised-----
- G** The forks cannot be raised by repeated pumping attempts-----
- H** Forks do not raise at the first pump stroke, or-----  
the pump do not operate in the whole pump stroke
- I** Pump does not react when changing over the release lever (sluggishness)---
- J** Forks cannot be lowered completely-----
- K** Forks do not lift horizontally-----
- L** Truck unable to lift 1000 kg to top position-----



**Cause**

	<u>Load heavier than the max. permissible</u>	See point 3.4
	<u>Oil deficiency</u>	See point 4.1
	<u>Valve control system needs adjustment</u> Low-pressure valve insert No. 400083	See point 4.3
	<u>Seal leakage</u>	See point 4.4
	<u>Valve cone does not seal completely</u> Almost always due to high-pressure valve insert No. 400672	See point 4.5
	<u>Release pin jammed in control valve</u> (In rubber bush or in valve body)	Replace rubber bush. Whole valve insert might need replacing. See point 4.3
	<u>Air in hydraulic system</u>	See point 4.6
<b>A</b>		
<b>B</b>		
<b>C</b>		
<b>D</b>		
<b>E</b>		
<b>F</b>		
<b>G</b>		
<b>H</b>		
<b>I</b>		
<b>J</b>		
<b>K</b>		
<b>L</b>		
	<u>Low temperature</u> below freezing	See point 4.1
	<u>Mast needs adjustment</u>	See point 4.9/ 4.10
	<u>Pressure relief valve defective</u>	See point 4.3
	<u>Lowering mechanism needs adjustment</u>	See point 4.8
	<p>If the problem cannot be solved by using the fault location key... ...please contact your distributor!</p>	

## 7.0 Good service after purchase



### 7.1 Ordering spare parts

The correct spare parts are obtainable from your dealer.

When ordering, please state:

- Serial number of the product
- Type and width/length of the product
- Spare part no.

### 7.2 Warranty/Compensation

Spare parts delivered during the warranty period will be invoiced. A credit note will be sent immediately after we have received and tested the defective parts and found that the warranty conditions have been met.

### 7.3 Service and repair

You should be able to make adjustments and perform minor repairs on the spot. However, major repairs should be left to the dealer who has well-trained personnel and the necessary special tools. The manufacturer has an exchange system for pumps/cylinders. These are renovated and delivered with warranty.

### 7.4 Warranty

The warranty covers material and assembly defects which, subject to inspection by us or our representative, are deemed to be faults or deficiencies that prevent normal use of the parts concerned. Such affected parts shall be sent to us carriage paid within the warranty period in force at the time in question.

The warranty does not cover normal wear and adjustments.

The warranty period is based on singleshift working.

#### **The warranty shall no longer apply if**

- the product has been used incorrectly,
- the product is used in environments for which it was not designed,
- the product has been overloaded,
- replacements of parts have been made incorrectly or original parts have not been used and consequential damages have arisen,
- service checks in accordance with our specifications and regular maintenance have not taken place,
- the fulfilment of the required service intervals by a qualified technician can not be proved.

**Control list and specifications concerning service and safety check can be ordered from Logitrans dealers.**

### 7.5 Liability exemption

The manufacturer accepts no responsibility for personal injury or material damage arising from deficiencies, defects or improper usage. The manufacturer accepts no responsibility for lost earnings, operating losses, lost time, lost profits or similar indirect losses incurred by the purchaser or a third party.

### **Periodic safety inspection**

Safety inspection should be performed by the supplier or other qualified persons at least once each year, unless local regulations state otherwise.

Such inspection shall be performed in accordance with the instruction manual. Test instructions and test forms are available from the distributor.