



Supplement to Instruction Manual

HL 1004 RF-PLUS EX

 II 2G Ex h IIB T6 Gb
 II 2D Ex h IIB T85°C Db

For operation in
explosive atmospheres

- zone 1 and 2 (gas)
- zone 21 and 22 (dust)

Characterised by the product mark

 Zone 1 & 2

 Zone 21 & 22

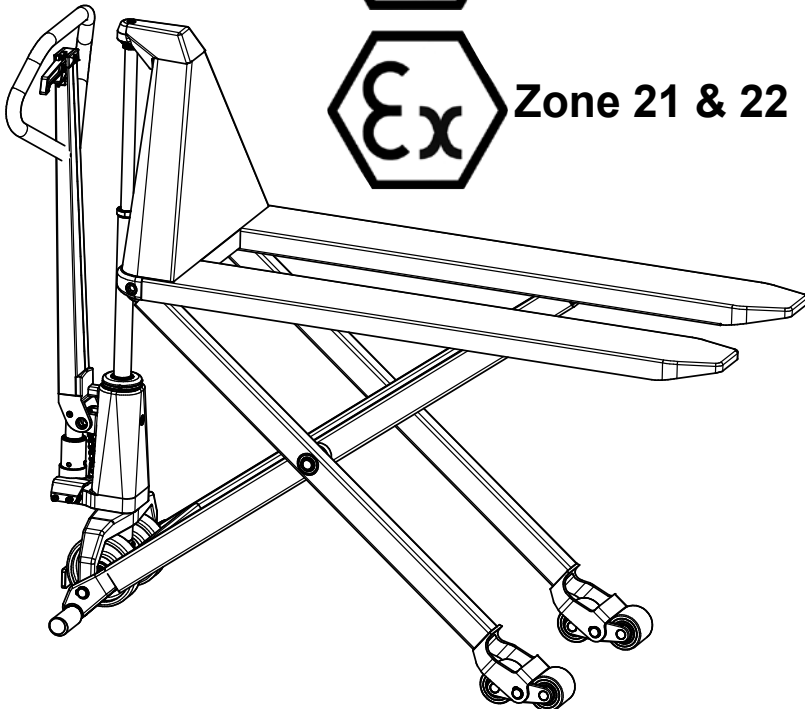

This supplement for the instruction manual of the basic product indicates that the construction of the product is in accordance with the safety precautions and that the product is suited for operation in explosive atmospheres - zone 1 and 2, generated by gases, vapours or mist in apparatus group IIB and in temperature class T6.

Or - zone 21 and 22 concerning dust in the temperature class T6.

The explosion proved construction is characterised by the following product mark:

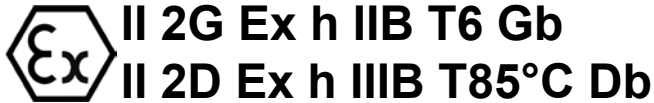

Safety precautions:

Dust, dirt, painting, acid, washout, overload and impacts can lead to a reduction or a total breaking of the earthing of electric/elektrostatic energy. The permanent compliance with the safety-related and technical stipulations, such as e.g. control of the wheel(s) with conductance concerning the above functional disturbances, is the responsibility of the user exclusively.

Additional wheels:

The explosion proved highlifter will have two anti-static wheels with a separate item no.

When reordering anti-static wheels, please state product type and whether the wheel is used as load roller or steering wheel.

EU DECLARATION OF CONFORMANCE

Manufacturer: **Logitrans A/S**
Hillerupvej 35
DK-6760 Ribe
Denmark



It is hereby declared that:

Machine: Product group: Highlifters - zone 1, 2 and zone 21, 22

Type:  II 2G Ex h IIB T6 Gb
II 2D Ex h IIIB T85°C Db
HL 1004 RF-PLUS EX

File no.: DTI 2017-1-0237A

Year of manufacture/
Serial No.:

- a)** Has been manufactured in conformance with the stipulations of the
- **ATEX Directive no. 2014/34/EC**
- b)** Has been manufactured in conformance with the stipulations of the standards:
- **EN 80079-36** • **EN 80079-37**

Name: **Gitte K. Berg**

Position: **CEO**

Company: **Logitrans A/S**

Signature: 

Product type declaration of:
09.02.2017

Distributor:

D100-8

The highlifter is further characterised by the following product mark:

The highlifter has to be empty when inserting into and withdrawing out of the load to be handled. Avoid dragging the highlifter against sharp edges.

Periodic safety inspection

Safety inspection should be performed by the dealer or other qualified persons at least once each year, unless local regulations state otherwise.

The safety inspection to be performed on the basis of form no. B278 and proved on form no. B284. Forms and instructions for the safety inspection are available at your dealer.