

Supplement to Instruction Manual

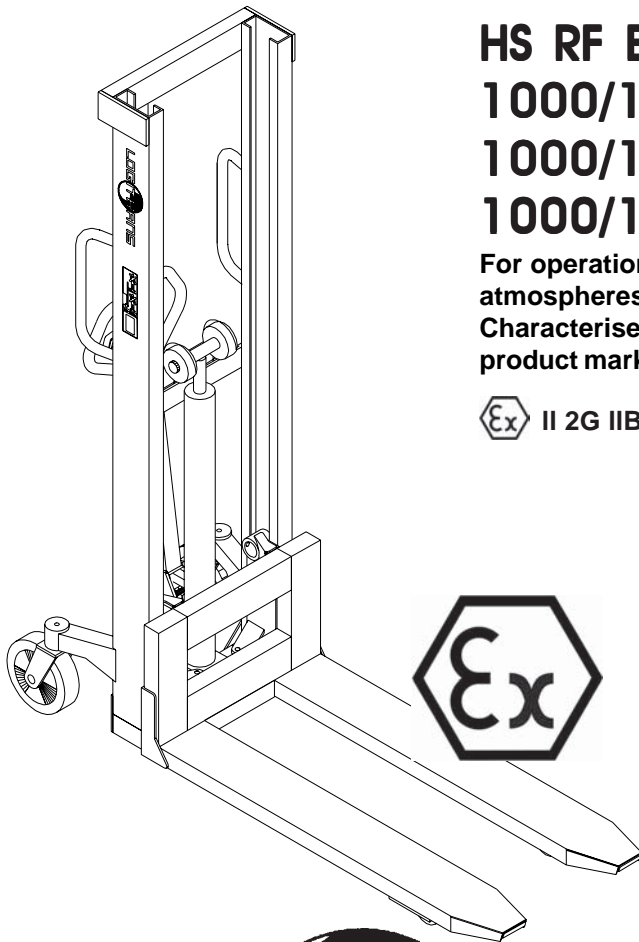

HS RF Ex
1000/1200
1000/1400
1000/1600

For operation in explosive
atmospheres - zone 1.
Characterised by the
product mark

 II 2G IIB T4



Zone 1

LOGITRANS

WWW.LOGITRANS.COM

This supplement for the instruction manual of the basic product indicates that the construction of the product is in accordance with the safety precautions and that the product is suited for operation in explosive atmospheres - zone1, generated by gases, vapours or mist in apparatus group IIB and in temperature class T4.

The explosion proved construction is characterised by the following product mark:



Safety precautions:

Dust, dirt, painting, acid, washout, overload and impacts can lead to a reduction or a total breaking of the earthing of electric/ elektrostatic energy. The permanent compliance with the safety-related and technical stipulations, such as e.g. control of the wheel(s) with conductance concerning the above functional disturbances, is the responsibility of the user exclusively.

Additional wheels:

The explosion proved stacker will have at least one anti-static wheel with a separate item no.

When reordering an anti-static wheel, please state product type and whether the wheel is used as steering or fork wheel.

EU DECLARATION OF CONFORMANCE

Manufacturer: **Logitrans A/S**
Hillerupvej 35
DK-6760 Ribe
Denmark



It is hereby declared that:

Machine: Product group: Stackers - zone 1

Type: HS 1000 Stainless Ex  II 2G IIB T4

Type approval: PTB 03 ATEX 5001x

Year of manufacture/
Serial No.:

- a) Has been manufactured in conformance with the stipulations of the
- **COUNCIL DIRECTIVE no. 98/37/EC**
 - **ATEX DIRECTIVE no. 94/9/EF**
- b) Has been manufactured in conformance with the stipulations of the standard:
- **EN-1757-1**
 - **EN-1755**
 - **EN-50014**

Name: **Erling Pedersen**

Position: **Product manager**

Company: **Logitrans A/S**

Signature: 

Product type declaration of:

01.08.2001

Distributor:

The stacker is further characterised by the following product mark:

When inserting and withdrawing into and out of pallets, avoid dragging the stacker against sharp edges.

Periodic safety inspection

Safety inspection should be performed by the supplier or other qualified persons at least once each year, unless local regulations state otherwise.

Such inspection shall be performed in accordance with the instruction manual. Test instructions and test forms are available from the distributor.