

LOGIFLEX SELF MAXI / SELFS MAXI

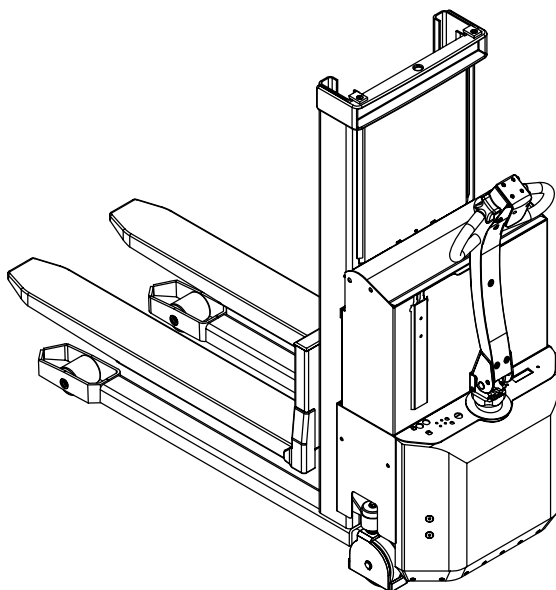
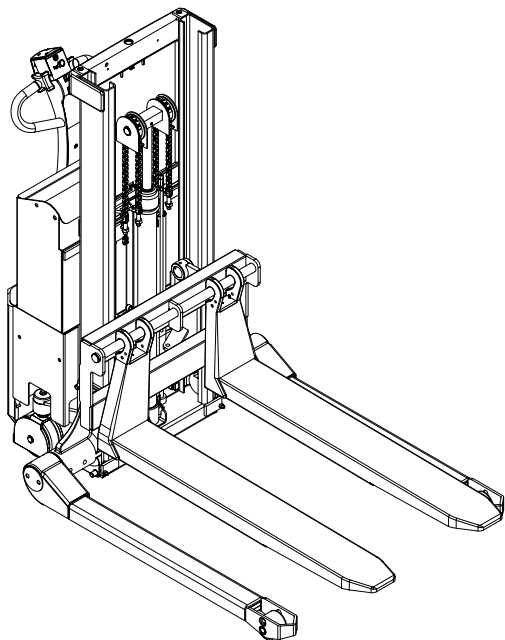

EU DECLARATION OF CONFORMANCE

Manufacturer: **Logitrans A/S**
Hillerupvej 35
DK-6760 Ribe
Denmark

It is hereby declared that:

Machine: Product group: Fully powered Logiflex

Type: SELF MAXI / SELFS MAXI

Year of manufacture/
Serial No.:

a) Has been manufactured in conformance with the stipulations of the

- **DIRECTIVE no. 2006/42/EC**
- **DIRECTIVE no. 2004/108/EC**
- **DIRECTIVE no. 2006/95/EC**

b) Has been manufactured in conformance with the stipulations of the standards:

- **EN ISO 3691-5**

Name: Erling Pedersen

Position: Product manager

Company: Logitrans A/S

Signature: 

Product type declaration of:
01.12.2010

Dealer:



Contents

| | |
|--|----|
| 1.0 Before the first lift... | 4 |
| 2.0 Functions and identifications | 5 |
| 3.0 How to operate the Logiflex Maxi | 6 |
| 3.1 Handling of pallets | 6 |
| 3.2 Handle functions | 8 |
| 3.3 Emergency stop | 9 |
| 4.0 Optimum safety | 10 |
| 4.1 Marking | 11 |
| 4.2 Personal safety | 12 |
| 4.3 Transport with load | 13 |
| 4.3 Avoid offset loads | 13 |
| 5.0 There must be a current supply... | 14 |
| 5.1 Fuses - replacement | 14 |
| 5.2 Wiring connections | 14 |
| 6.0 Long live the Logiflex Maxi | 15 |
| 6.1 Lubrication and hydraulic oil | 15 |
| 6.2 Oil change | 16 |
| 6.3 Hydraulic pump | 17 |
| 6.4 Cleaning | 17 |
| 6.5 Fork adjustment | 18 |
| 6.6 Adjustment of lifting chain | 18 |
| 6.7 Adjustment of side play | 19 |
| 6.8 Adjustment of speed and acceleration | 19 |
| 7.0 Fault location key | 20 |
| 7.1 Remedy | 22 |
| 8.0 Good service after purchase | 24 |
| 8.1 Ordering spare parts | 24 |
| 8.2 Warranty/Compensation | 24 |
| 8.3 Service and repair | 24 |
| 8.4 Warranty | 24 |
| 8.5 Liability exemption | 24 |





1.0 Before the first lift...

The **Logiflex Maxi** is manufactured in accordance with safety directives.

Among the subjects dealt with in this **Instruction Manual** are:



- Proper application
- Physical limitations of the product
- Risks with improper use

Therefore please read this **Instruction Manual** carefully!

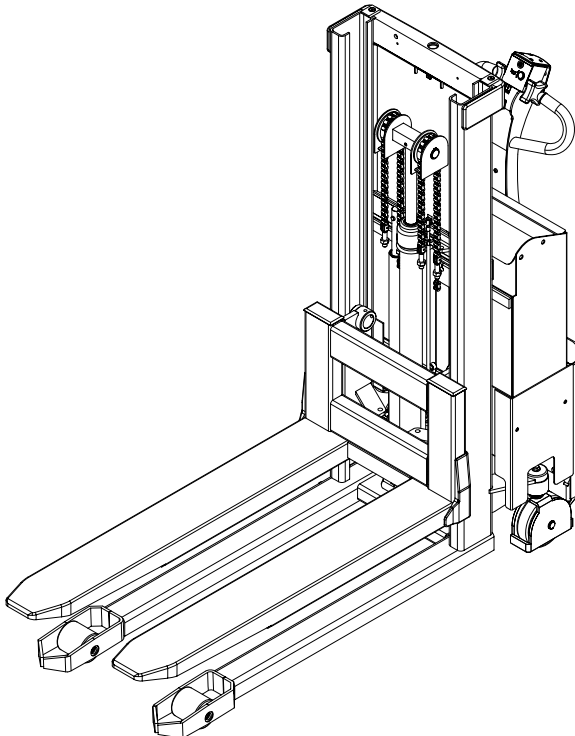



2.0 Functions and identifications

1. Safety Switch
2. Horn
3. Lift/Lower
4. Forward/Reverse
5. Multiflex Function
6. Handle
7. Battery indicator / hour counter
8. Emergency Stop
9. Ignition Key
10. Charger plug (external charger)
11. Charging Lamps (built-in charger)

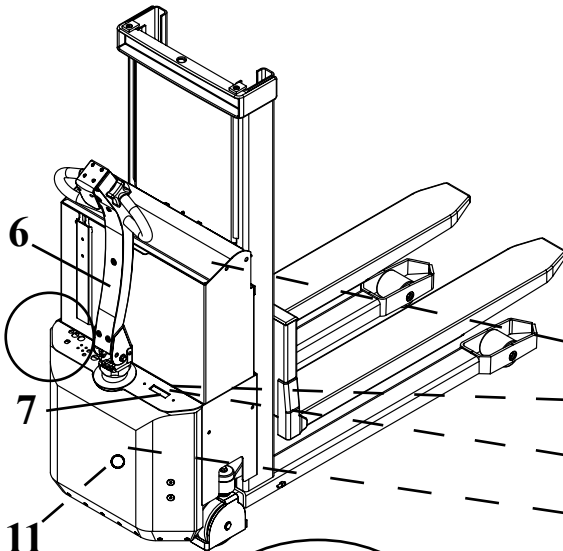
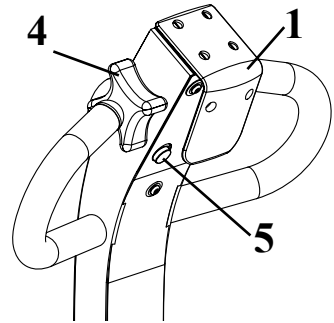
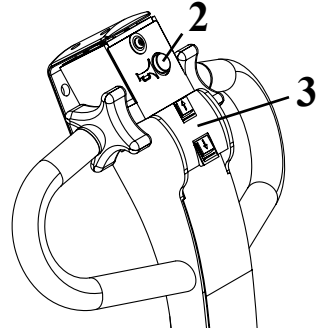

Identifications

— Battery label (below the cover)

— Name plate, serial number

— Capacity plate

— Truck number, stamped in chassis behind the rear cover.

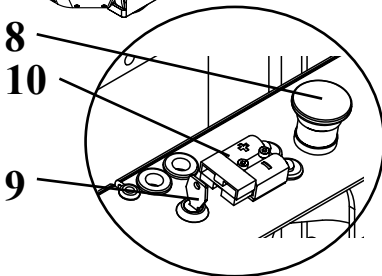



3.0 How to operate the Logiflex Maxi

3.1 Handling of pallets

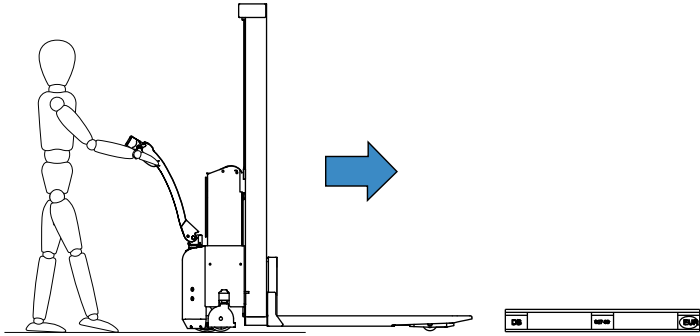

For proper operation,
stand behind the handle!

The forks will lift 190 mm
before the telescopic mast begins
to extend.

(SELF Maxi 2050 - 3300)

(SELS Maxi 2020 - 3270)

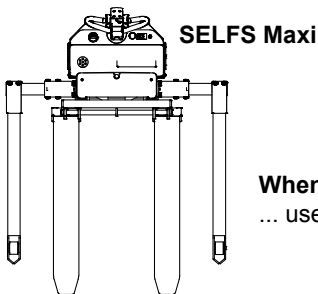
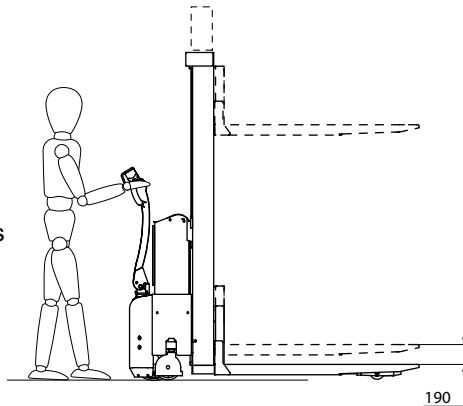

SELFS Maxi

When handling closed pallets...
... use straddle Logiflex.

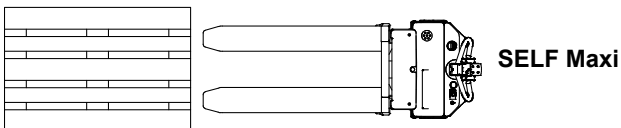

SELF Maxi

3.0 How to operate Logiflex Maxi

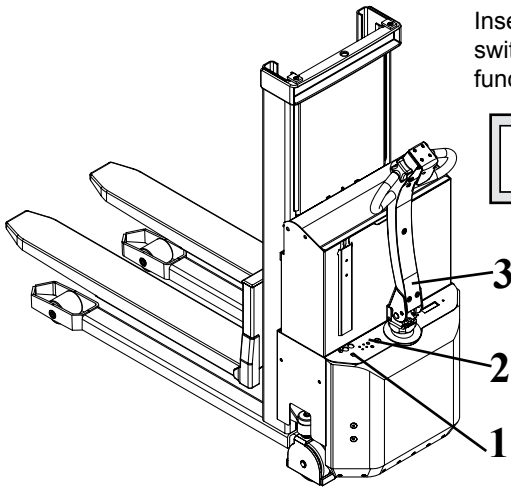

Insert key (1) and turn clockwise to switch on control current ready for function activation.

! Note!!! Emergency stop (2) must not be activated.

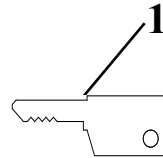

The control functions of the stacker are located in the handle (3).
- The functions are dependent on the positions of the handle!

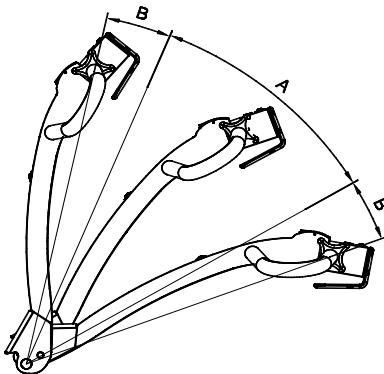

Position A: Drive position
Drive current on
Brake deactivated

**Position B: Stop/Brake/
Emergency Stop**
Drive current off
Brake activated

3.0 How to operate the Logiflex Maxi

3.2 Handle functions

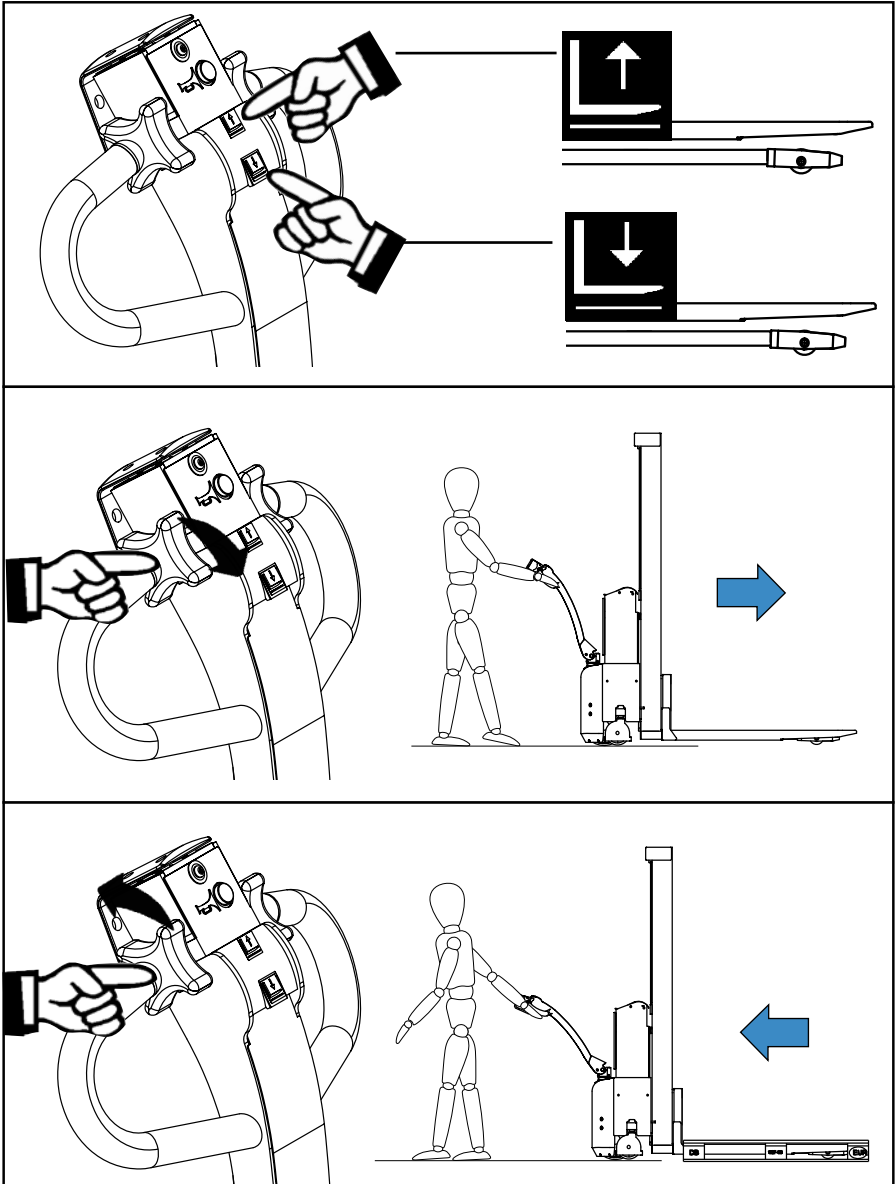

3.0 How to operate the Logiflex Maxi

3.2 Handle functions

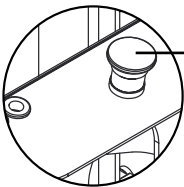
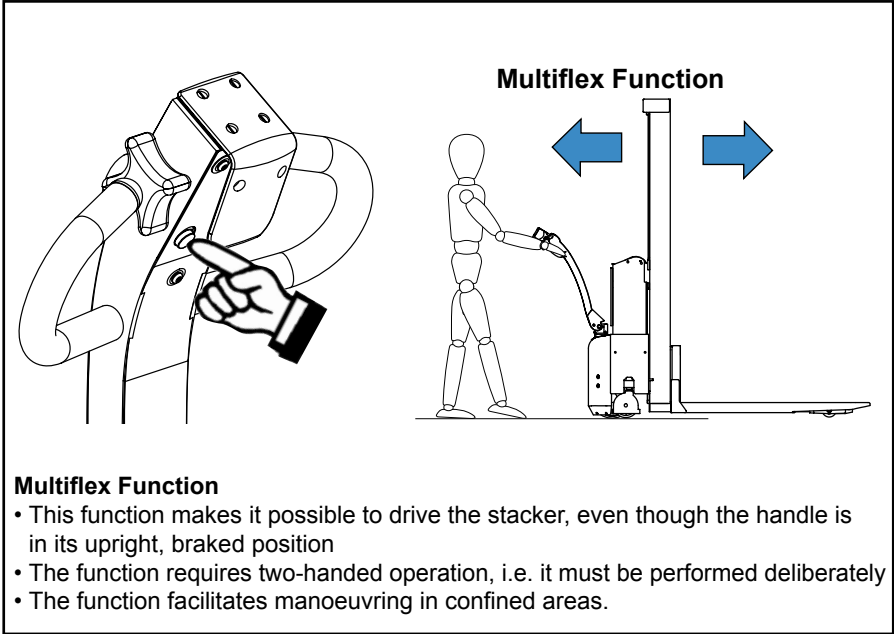

3.2 Emergency stop

The product has an emergency stop. When activating the emergency stop, the main current supply is switched off.

- The movement of the forks stops immediately
- Driving with the truck stops immediately
- The emergency stop is deactivated by turning the switch to the right



4.0 Optimum safety

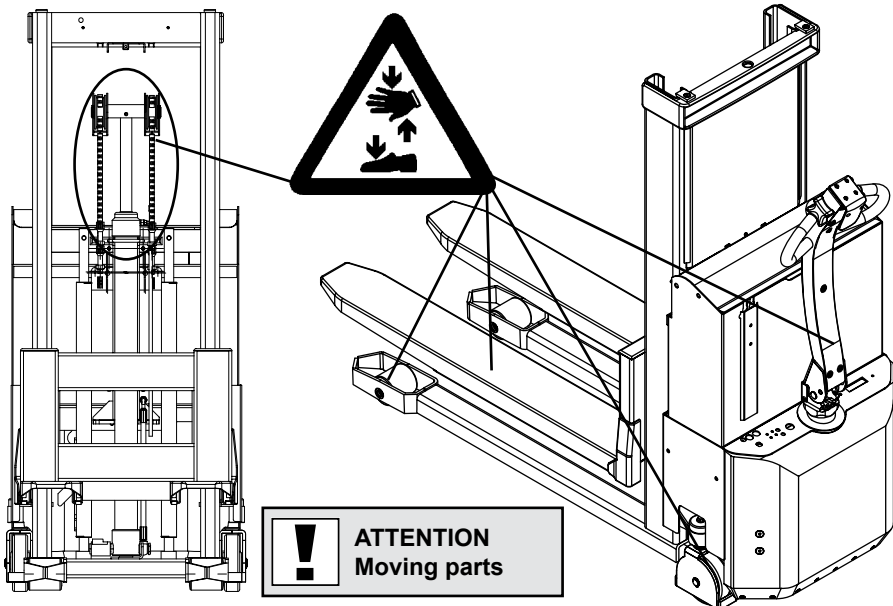

Safety regulations

- Never walk under a raised load!
- Before lowering the forks, make certain that no foreign elements can hinder the free lowering of the forks.
- Logiflex Maxi is designed for use on an even and level floor.
- During transport the forks shall be raised as little as possible.
- Transport with raised forks should be made over the shortest possible distances and at low speed.
- Check that the chains lift equally. They shall be equally tight when the forks are loaded
- Chains and chain bolts must not be damaged. Chains that have become permanently stretched (max. 2% of original length) must be scrapped.



4.0 Optimum safety

4.1 Marking

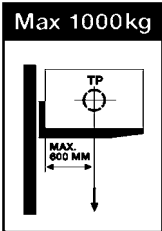

The mast lifting capacity and the corresponding centre of gravity distance are given by the pictogram on the side of the mast.

The lifting capacity of the mast is the same as the max. lifting capacity of the product.

Max. lifting capacity is set on the safety valve of the product.

Specific to Logiflex Maxi - with load limitation at significant lifting heights

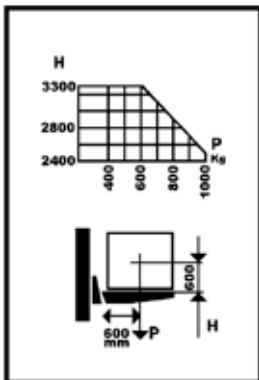

- The fork bracket loading is dependent on the lifting height and can be read on the load diagram.

- Load limitation at significant heights is incorporated to give greater stacker stability and operator safety.

NOTE! If the Logiflex Maxi is equipped with optional extras, the load limitation of the optional extras will be valid.

4.0 Optimum safety

4.2 Personal safety

The safety switch on the end of the handle ensures that the operator cannot be trapped when the stacker is reversed.

When the safety switch is activated, the stacker will change direction and move forwards.

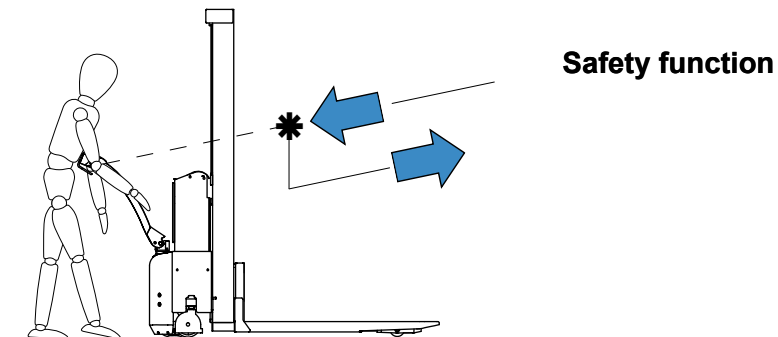

4.0 Optimum safety

4.3 Transport with load

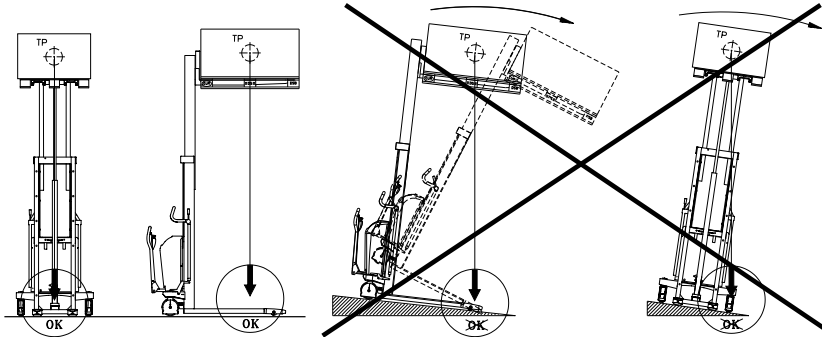

The load centre is never allowed to exceed the center line of the wheels.
The driving speed is reduced when lifting the forks above 400 mm.
The Logiflex Maxi is designed for use on even and level floor. During transport the forks shall be raised as little as possible. Transport with raised forks should be made over the shortest possible distances and at low speed.

4.4 Avoid overloads

The maximum load must not be exceeded.
Remember, the stacker is designed for evenly distributed load; - goods on pallets etc.
- If the forks are point-loaded on one side, there is a risk of bending.

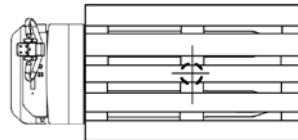

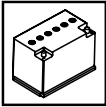

5.0 There must be a current supply..

5.1 Fuses - replacement

There are 5 fuses in the electrical circuit, located behind the plate with this pictogram.

- A) 40 Amp fuse (only when optional extras)
- B) 60 Amp fuse for lifting motor
- C) 80 Amp fuse for driving motor
- D) 5 Amp fuse in the control current circuit
- E) 15 Amp fuse for built-in charger

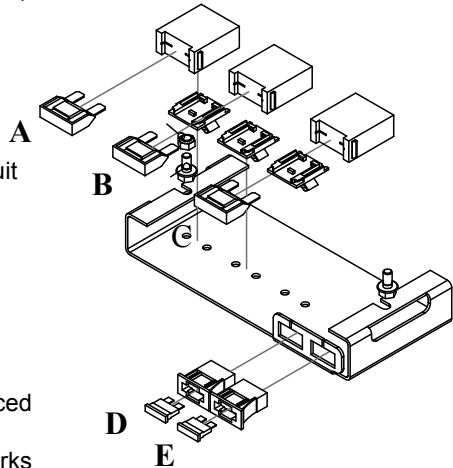

Replacement:

The old fuse is to be removed and replaced by a new one of the same size. Do not use a bigger fuse, as the fuse works as protection of the electric circuit.

Find out why fuses blow!

5.2 Wiring connections

Many operational disturbances are caused by bad connections in the electrical circuit. Make sure that the connections are in order.

Check connections regularly for damage at insulating caps or bad connections at plugs etc.

Verdigris must be removed from cable plugs. Keep all screw/nut connections tight.



6.0 Long live Logiflex Maxi

Regular inspection and the replacement of worn or defective parts in good time will prolong the life of the Logiflex Maxi. "Prevention is better than repair", therefore ensure:

- Correct usage
- Regular cleaning
- Periodic safety and service inspection (see the back page)
- Due to safety reasons, the below points have to be checked every 3 months:
 - Loose screws and nuts have to be tightened up.
 - Breaches, cracks or deformations are not allowed on the load-bearing parts.
 - Wearing parts, such as brakes, wheels and bearings, are to be adjusted or changed continuously
 - The lifting chains are to be checked, see 6.6

6.1 Lubrication and hydraulic oil



Under normal operation conditions the Logiflex Maxi requires no lubrication.

All ball bearings are sealed and lubricated for life, and moving parts have self-lubricating bearings or are treated with grease. The hydraulic system is filled with hydraulic oil of viscosity class ISO VG 15.

An additive is added to the oil. The concentrate reduces friction and wear and protects against corrosion. Pre-mixed hydraulic oil with additive is available from the dealer. To ensure that the cylinder pipe is lubricated and thereby protected against corrosion, it is important to lift the forks to top position frequently. The oil is suitable for use in the temperature range -10° to $+50^{\circ}$ C. A thinner oil is recommended for temperatures lower than -10° C (if necessary, contact your dealer).

6.0 Long live Logiflex Maxi...

6.2 Oil change

Draining the oil:

1. Bring the unloaded forks down to the lowest position.
2. Most of the oil can be drained by loosening the hydraulic hose union in the bottom of the cylinder. Activate the hydraulic pump by pressure on the switch. The oil will run out.
3. Take off the side plates.
4. Take off the cables of the battery and push the battery box to the right side. (Fig. A)
5. The remaining oil can be drained from the oil tank by taking off the oil tank.
6. Place the oil tank and the hydraulic hose again.
7. Oil is filled in by removing the angular hose nipple from the tank.
8. Oil quantity:

The oil level is measured from the upper edge of the tank and downwards

SELF Maxi 1001/920 - 1600

SELFS 1001/890 - 1570

approx. 3 litre 40 mm

SELF Maxi 1001/1910 - 2450

SELFS Maxi 1001/1880-2420

approx. 3,5 litre 32 mm

SELF Maxi 1001/2850 & SELFS Maxi 1001/2820

approx. 4 litre 25 mm

SELF Maxi 1001/3300 & SELFS Maxi 1001/3270

approx. 4,5 litre Metal tank
half full.

9. Refit the angular hose nipple and bleed the system (see 6.3)

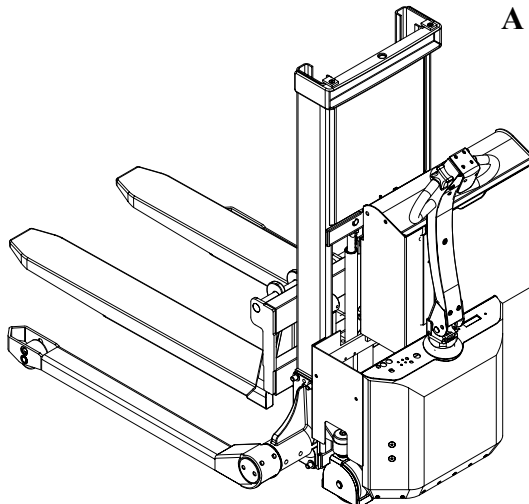

6.0 Long live Logiflex Maxi...

6.3 The hydraulic pump

The hydraulic pump has a S3 “periodic intermittent duty” of 10%. This means that the pump in total is allowed to operate 1 minute for a period of 10 minutes.

Note! If the pump operates more than 10%, the motor will be damaged due to superheating.

Bleeding the hydraulic system

With a load of 50-100 kg, the forks must be raised and lowered to top and bottom position 2-3 times.



6.4 Cleaning

When cleaning the Logiflex Maxi, do not direct the jet onto bearings and seals.

Otherwise the grease will be washed out and the life of the equipment shortened.

Cleaning of the plastic screen (polycarbonate)

The screen is to be washed with slightly warm water added a neutral cleaning material, and afterwards washed with clean water.

Use a soft sponge, a woollen cloth or a wash leather.



Never use sharp objects or solvent cleaners when cleaning.

6.0 Long live Logiflex Maxi...

6.5 Fork adjustment

Two of the rollers on the fork bracket are mounted on eccentric pins, so that they can be adjusted. The adjustable rollers are at the top.

1. Loosen screw (pos. 91)
(key width 5 mm).
2. Eccentric pins (pos. 56)
(key width 8 mm) can now be turned to give the necessary fork adjustment.
3. Adjustment must be made on both sides to ensure uniform loading of the rollers.

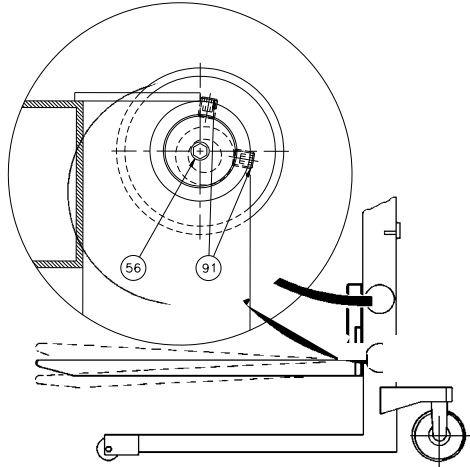

6.6 Adjustment of lifting chain

The chains shall be adjusted so that:

- they lift equally
- they are equally tight
- The lifting movement has to stop in the cylinder, before the mast rolls touch the top stop.
- mast rolls touch the top stop.

After adjusting, please check:

- a: Fork bracket: the forks have to be placed above the wheels
- b: Adjustable carriage: the forks are to be kept clear of the floor.

The nuts (pos. 18) are to be adjusted
(nut M12, key width 19 mm).

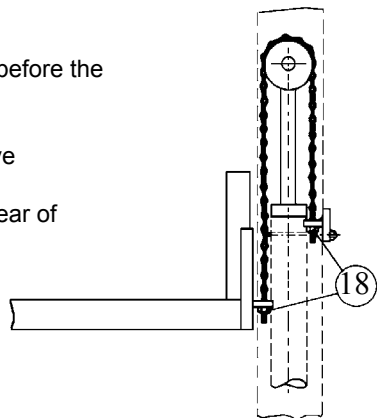

6.0 Long live Logiflex Maxi...

6.7 Adjustment of side play

(In the mast rolls of the right side of the fork bracket)

- 1: Screw (A) is loosened counter-clockwise, until resistance disappears.
- 2: Turn the screw clockwise, until resistance appears. The following 1.5 to 2.5 turns of the screw will be a tightening of the spring (C).
- 3: When a larger resistance appears, make 0.25 turn counter-clockwise, and the counter nut (B) will be tightened.
- 4: Pump the forks to its top position, and when lowering it has to slide to the bottom. If this is not the case, loosen screw A, make c. 0.5 turn counter-clockwise and repeat point 4.

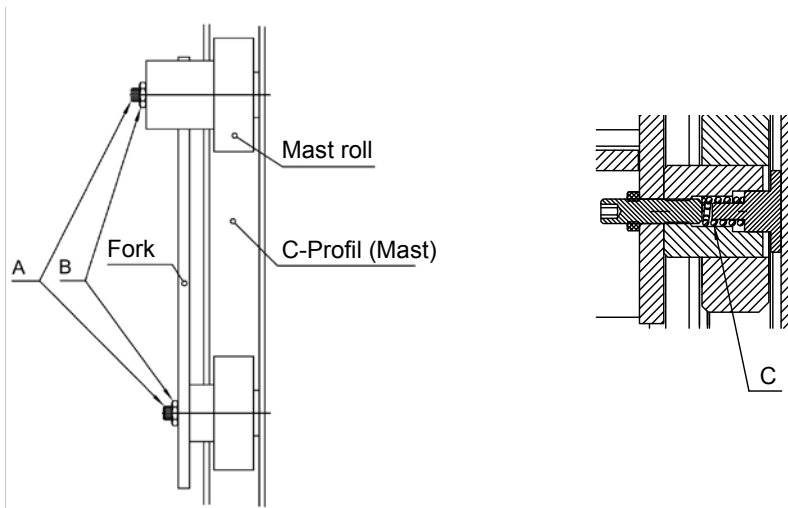

6.8 Adjustment of speed and acceleration

In the controller it is possible to reduce the driving speed.

The parameters for speed can be reprogrammed by contacting the dealer.



7.0 Fault location key

When the Logiflex is used every day, adjustments and the replacement of worn parts might be necessary.

Adjustments and minor repairs can easily be made on the spot. Major repairs should, however, be carried through by the dealer who has a well-trained staff and the necessary special tools.

| | |
|--|---|
| | Before asking the dealer for assistance... ...try the fault locations key! |
|--|---|

Symptoms and observations

- A** Stacker does not drive when the handle is tilted and drive grip turned!
 - no click can be heard from relays when the handle is tilted _ _ _ _ _
 - no click can be heard when the multiflex button is activated _ _ _ _ _
 - the motor makes a humming noise _ _ _ _ _
- B** Stacker drives slowly _ _ _ _ _
- C** Stacker brakes when drive grip is released (handle tilted) _ _ _ _ _
- D** Stacker does not brake when handle is tilted to upper or lower position _ _ _ _ _
- E** Stacker brakes too little/too much _ _ _ _ _
- F** Forks do not lift when "UP" is pressed _ _ _ _ _
- G** No click can be heard when "UP" is pressed _ _ _ _ _
- H** Forks lift only a little/not to max. height when "UP" is pressed _ _ _ _ _
- I** Forks do not sink when "DOWN" is pressed _ _ _ _ _
- J** Forks sink slowly _ _ _ _ _
- K** The battery is not charged (no light in charging lamp) _ _ _ _ _

Cause

Remedy

| | | |
|----------|--|-----|
| | Inadequate power supply | 1) |
| | Battery discharged | 2) |
| | Fault in on/off switch | 3) |
| | Fault in control current circuit | 4) |
| | Fault in main/power current circuit | 5) |
| | Too little current on battery | 6) |
| | No current on brake | 7) |
| | Brake needs adjusting | 8) |
| | Insufficient oil in tank. Load too heavy, safety valve is set wrongly | 9) |
| | No current on solenoid valve | 10) |
| | Oil circuit leakage | 11) |
| | Fault in charging circuit | 12) |
| A | | |
| - | ● ● ● ● ● | |
| - | ● ● ● ● ● | |
| - | ● ● ● ● ● | |
| B | ● ● ● ● ● | |
| C | ● ● ● ● ● | |
| D | ● ● ● ● ● | |
| E | ● ● ● ● ● | |
| F | ● ● ● ● ● | |
| G | ● ● ● ● ● | |
| H | ● ● ● ● ● | |
| I | ● ● ● ● ● | |
| J | ● ● ● ● ● | |
| K | ● ● ● ● ● | |

If the problem cannot be solved by using the fault location key...

...read the error code, see paragraph 7.1 and contact the dealer!



7.0 Fault location key

7.1 Remedy

- 1) Check to ensure that the key (A) is turned clockwise and that emergency stop (B) is not activated.
- 2) Charge battery - (see separate instruction manual for battery and charger)
Access to the battery is achieved by tipping the cover (C).
 - If necessary, check the liquid level in battery cells.
 - The remaining capacity of the battery can be checked with an acidometer
- 3) Check switch (D). Check cable connections on switch.
- 4) Check control current fuse (F).
 - If the fuse is intact and the stacker does not drive, contact the dealer.
- 5) Check main fuse (G) and pump fuse (I)
Check cable connections on drive motor and pump motor. If no fault can be found and the stacker does not drive, contact the dealer.
- 6) Check battery, (see point 2 above).
- 7) Check the wheel motor. The wire connection for the brake is checked.
These must be connected. If no fault can be found and the stacker still brakes, contact the dealer.
- 8) Brake needs adjustment.
The brake force is adjusted by turning the adjusting screw on the outside of the brake. The brake force is increased by tightening clockwise.
- 9) Remove battery and replenish oil (see point 6.2). Max. load (given on nameplate) If the stacker cannot lift max load contact the dealer.
- 10) Contact the dealer.
- 11) Locate the oil leak and contact the dealer.
To localise the leak it is necessary to remove the rear cover.
- 12) Check the fuse for the charger (J)
If the fuse is intact and the truck does not charge, contact the dealer.

7.0 Fault location key

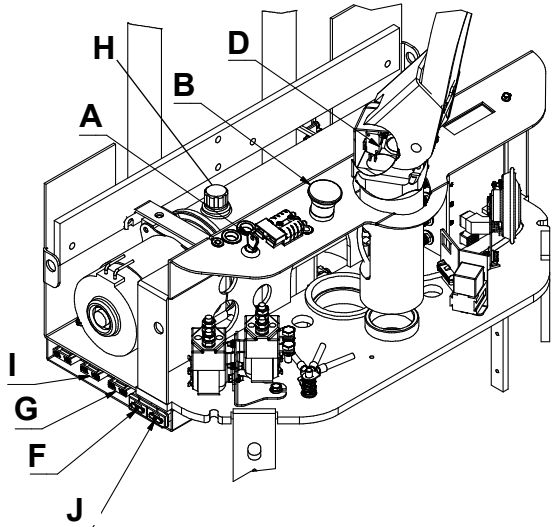
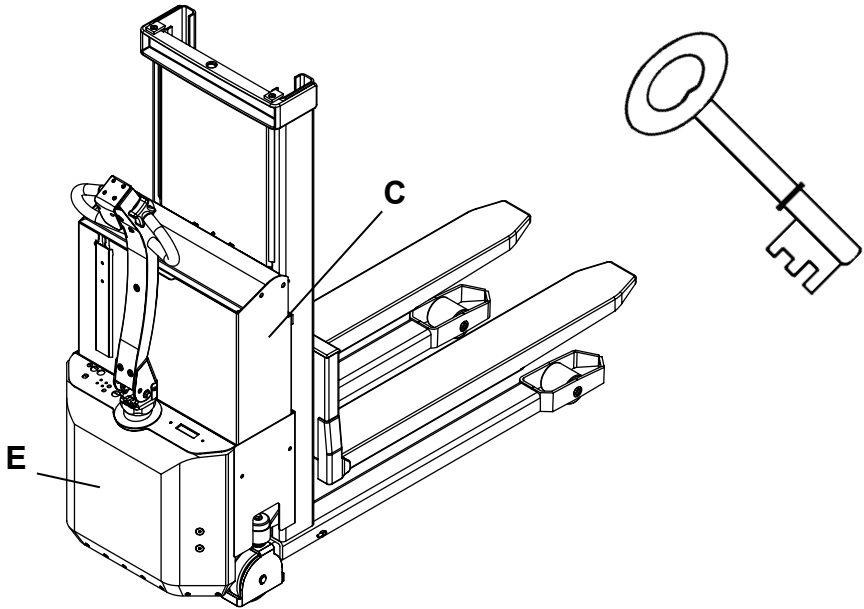



8.0 Good service after purchase

8.1 Ordering spare parts

The correct spare parts are obtainable from your dealer.

When ordering, please state:

- Serial number of the product
- Type and width/length of the product
- Spare part no. Please find spare part no. on www.logitrans.com.

8.2 Warranty/Compensation

Spare parts delivered during the warranty period will be invoiced. A credit note will be sent immediately after we have received and tested the defective parts and found that the warranty conditions have been met.

8.3 Service and repair

You should be able to make adjustments and perform minor repairs on the spot. However, major repairs should be left to the dealer who has well-trained personnel and the necessary special tools.

8.4 Warranty

The warranty covers material and assembly defects which, subject to inspection by us or our representative, are deemed to be faults or deficiencies that prevent normal use of the parts concerned. Such affected parts shall be sent to your Logitrans dealer carriage paid within the warranty period in force at the time in question, together with a copy of the documentation for the service performed (B284 - see the back page). The warranty does not cover normal wear and adjustments. The warranty period is based on singleshift working.

The warranty shall no longer apply if

- the product has been used incorrectly,
- the product is used in environments for which it was not designed,
- the product has been overloaded,
- replacements of parts have been made incorrectly or original parts have not been used and consequential damages have arisen,
- if the product is changed or accessories, not being approved by Logitrans, are used,
- it can not be proved that a qualified technician has performed the service check-according to the requirements stated in the instruction manual (see the back page).

8.5 Liability exemption

The manufacturer accepts no responsibility for personal injury or material damage arising from deficiencies, defects or improper usage. The manufacturer accepts no responsibility for lost earnings, operating losses, lost time, lost profits or similar indirect losses incurred by the purchaser or a third party.

Periodic service check

Service check is required once each year, or at least for every 500 hours of operation.

The service check is to be performed on the basis of form no. B280 and proved on form no. B284. Forms and instructions for the service check are available at your dealer.

Periodic safety inspection

Safety inspection should be performed by the dealer or other qualified persons at least once each year, unless local regulations state otherwise.

The safety inspection to be performed on the basis of form no. B278 and proved on form no. B284. Forms and instructions for the service check are available at your dealer.