

EHS 1000RF-SEMI

LOGIBOOK

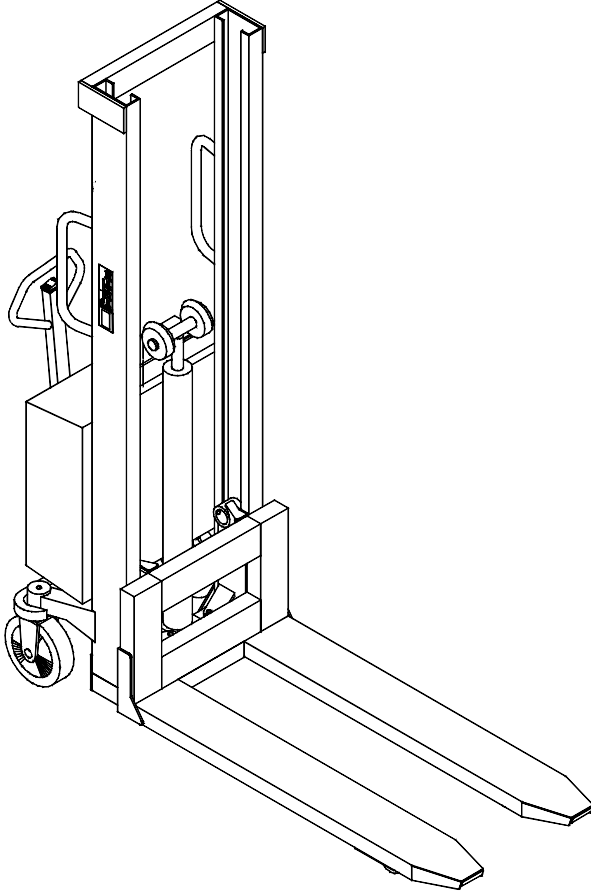

www.logitrans.com



Logitrans
lifting performance

EU DECLARATION OF CONFORMANCE

Manufacturer: **Logitrans A/S**
Hillerupvej 35
DK-6760 Ribe
Danmark

It is hereby declared that:

Machine: Product group: Stackers

 Type: EHS 1000RF-SEMI

 Year of manufacture/
Serial No.:

a) Has been manufactured in conformance with the stipulations of the

- **COUNCIL DIRECTIVE no. 98/37/EC**
- **COUNCIL DIRECTIVE no. 89/336/ECC**

b) Has been manufactured in conformance with the stipulations of the
standard:

- **EN-1757-1**

Name **Erling Pedersen**

Position: **Product manager**

Company: **Logitrans A/S**

Signature: 

Product type declaration of:
01.01.2000

Distributor:

1.0 Before the first lift...

The **Logitrans** Stacker is manufactured in accordance with safety directives.

Among the subjects dealt with in this **Instruction Manual** are:

- *Proper application*
 - *Physical limitations of the product*
 - *Risks with improper use*
- **Therefore please read this Instruction Manual carefully!**

2.0 How to operate the stacker

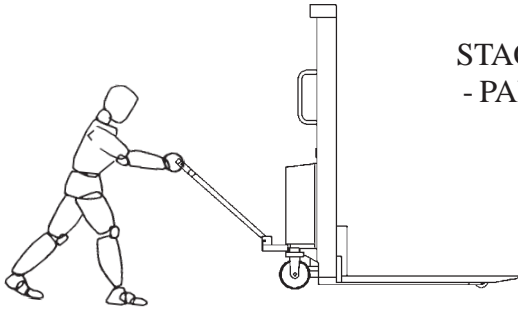

STACKER APPLICATION
- PALLET HANDLING -



For proper operation,
stand behind the handle.

Push/pull - raise/lower

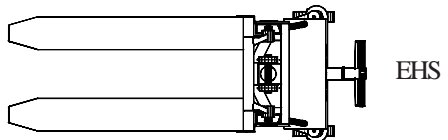
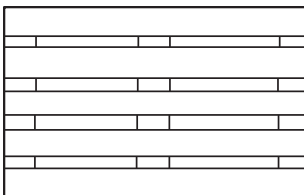
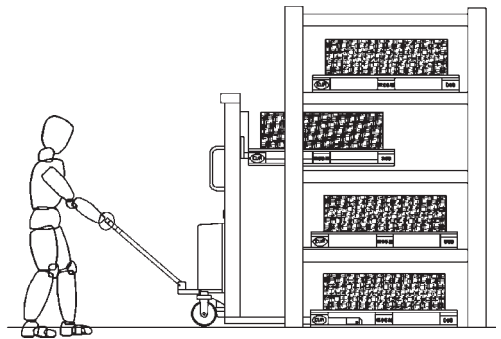

3.0 Optimum safety



3.1 Avoid overloads

The maximum load must not be exceeded. Remember, the stacker is designed for evenly distributed load, - goods on pallets etc. If the forks are pointloaded on one side there is a risk of bending.

3.2 Avoid offset loads

The load must be evenly distributed. The maximum centre-of-gravity distance from the front of the fork mast (given on the truck) must not be exceeded. A greater distance will impair safety and increase the risk of toppling.

Goods on pallets, etc. must be properly secured so that they cannot fall off during transport, when the truck is lifted, or when the truck must remain lifted for a time.

Marking

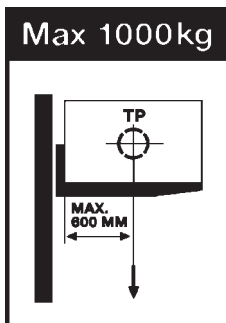

The mast lifting capacity and the corresponding centre of gravity distance are given by the pictogram on the side of the mast.

The lifting capacity of the mast is the same as the max. lifting capacity of the product.

Max. lifting capacity is set on the safety valve in the product.



3.3 Driving loaded

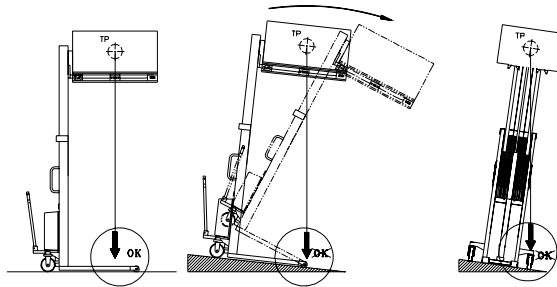

The stacker is designed for use on even and level floor. During transport the forks shall be raised as little as possible. Transport with raised forks should be made over the shortest possible distances and at low speed.

3.4 Emergency braking

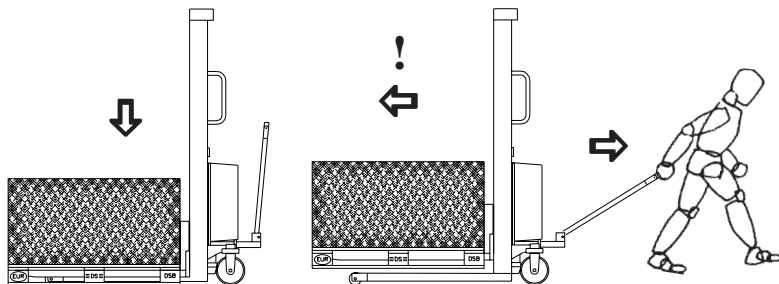
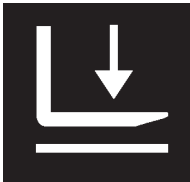

If it becomes necessary to use the load as a brake to prevent the stacker running loose, activate the DOWN button quickly until the load reaches the ground.

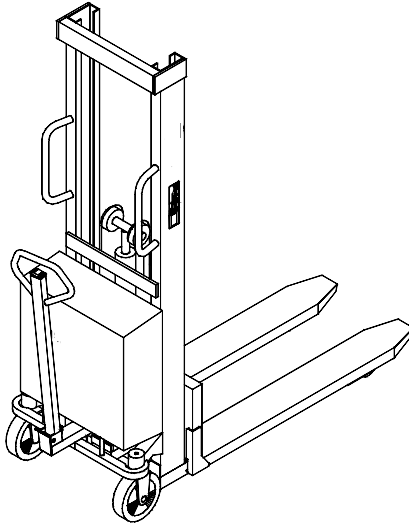

Safety regulations



- Never walk under a raised load!
- Before lowering the forks, make certain that no foreign elements can hinder the free lowering of the forks.
- The stacker is designed for use on even and level floor.
- During transport the forks shall be raised as little as possible.
- Transport with raised forks should be made over the shortest possible distances and at low speed.
- Check that the chains lift equally. They shall be equally tight when the forks are loaded.
- Chains and chain bolts must not be damaged. Chains that have become permanently stretched (max. 2% of original length) must be scrapped.



3.5 Safety system

- A:** **Fuses:** motor protector and protection against electrical overload.
- B:** **Safety/pressure relief valve:** protection against mechanical and hydraulic overload. Set by the manufacturer at the maximum design load (see product nameplate).
- C:** **Hose safety valve:** protection against load "falling" in the event of hose fracture.
- D:** (Pos. 1-4, see section 8.0)

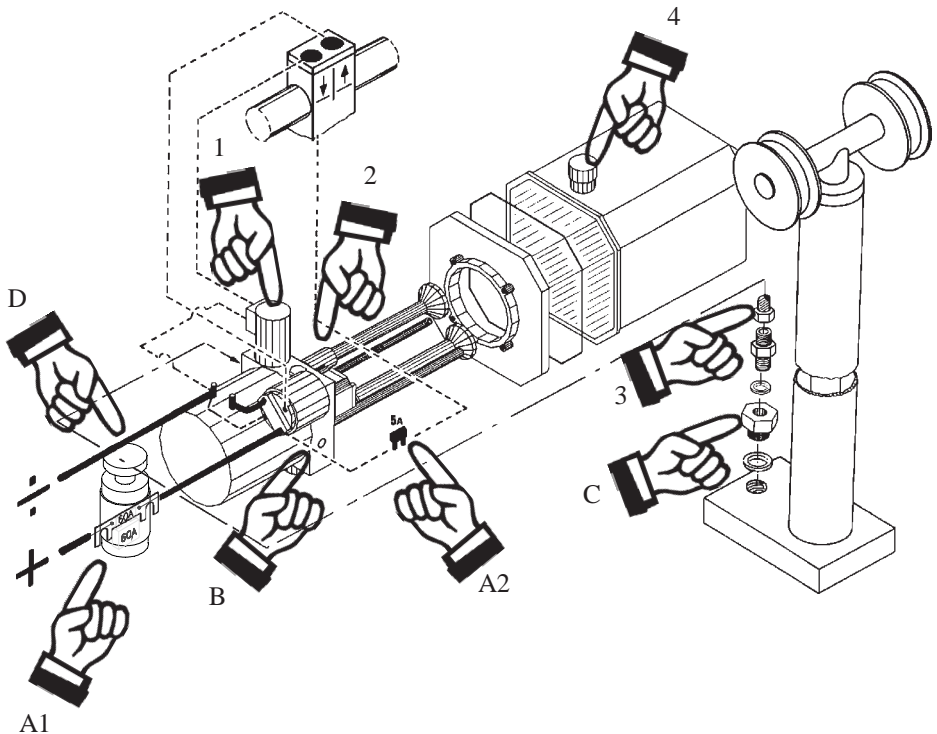

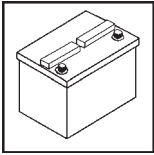

4.0 There must be a current supply

4.1 Battery specifications

The manufacturer offers two different battery types recommended for EHS 1000:

	Semi-trak 986034	Semi-trak 986036	Tubular cell 986014
Voltage	12V	12V	12V
Capacity	60Ah/5h	105Ah/5h	100Ah/5h
Recommended for	Normal use		Severe daily use
Life in cycles at 80% discharge	Approx. 300 - See note 1		Approx. 1200 - See note 2
MAINTENANCE Liquid inspection	Acid level must be min. 5 mm and max. 10 mm above cells. Add distilled water if necessary.		
MAINTENANCE Poles	Verdigris to be removed from poles regularly. Poles to be greased after cleaning.		
Charge condition to be measured with	Acidometre, voltmeter or battery condition tester		
Charging frequency	When needed, max once per day. - See note 1		At 80% discharged, max once per day. - See note 2
Charging voltage measured across poles during charging	15,2V		
Battery dimensions LxWxH	278x175x190	513x189x223	514x175x232
Battery weight	20 kg	40 kg	41 kg

Note 1: Battery life: 300 cycles at 80% = approx. 600 cycles at 50%

Note 2: Longest battery life obtained when the battery is charged on being 80% discharged. 1 charge = 1 cycle

Dry-charged batteries must be filled with battery acid 37.5% H₂SO₄ specificgravity 1.28 before they are used for the first time.

4.2 Checking the battery

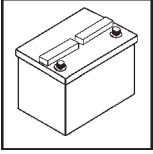

Method A for SEMI-TRAK and TUBULAR CELL:

Check acid density in the six battery cells with an acidometer.
Check each cell - max. difference between each cell 0.04 kg/l.

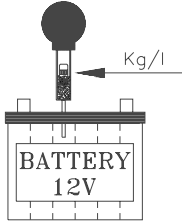

DENSITY

1.26 - 1.28 kg/l Fully charged
1.19 - 1.20 kg/l 1/2 charged
1.16 - 1.17 kg/l 1/4 charged
1.10 - 1.11 kg/l Discharged

Method B for all three battery types:

To measure the voltage, use a digital voltmeter (DC) on the battery poles. The truck must not have been in use for the previous 30 minutes.

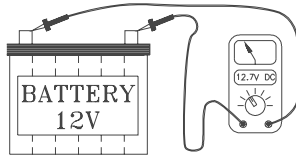

Approx. 12.7 V	Fully charged
Approx. 12.2 V	1/2 charged
Approx. 12.0 V	1/4 charged
Approx. 11.6 V	Discharged

4.3 Battery charging

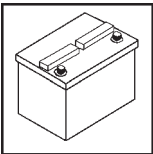

Charging must be performed with a charger correctly set with the charging voltage for the battery type, see point 4.1.

The manufacturer recommends a charger of 10-15 amp capacity.
During charging, the temperature in the battery must not exceed 50° C.

Charging simultaneously with truck operation is not advised.

4.4 Warnings and information on battery

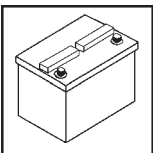

Avoid the use of naked flame in the vicinity of tubular cell and Semi-Trak batteries.

The charging of tubular cell and Semi-Trak batteries gives off gases that can be explosive. Therefore charging should be performed in a ventilated room.

At temperatures around freezing point, battery capacity is reduced by 30%.

4.5 Fuses - replacement

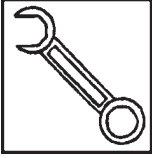

There are two fuses in the electrical circuit.
- See illustration under point 3.5:

80 amp fuse in main supply
from battery
(location: see A1, point 3.5)



5 amp fuse in control current
circuit
(location: see A2, point 3.5)

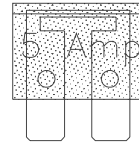

Replacement:

Before replacing fuse, disconnect battery + pole. The old fuse can then be removed and replaced by a new one of the same size. Do not insert a larger fuse; the fuse acts as a protector for the pump motor.

Find out why fuses blow!

4.6 Wiring connections

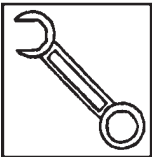

Much operational disturbance is caused by poor connections in the electrical circuit. Make sure connections are in order.

Check connections regularly for damage at insulating caps or looseness at plugs, etc.

Verdigris must be removed from lead plugs. Keep all screw/nut connections tight.

5.0 Long live the stacker

Regular inspection and the replacement of worn or defective parts in good time will prolong the life of the stacker. "Prevention is better than repair", therefore ensure:

- Correct usage
- Regular cleaning
- Oil changes at the correct intervals
- Periodic safety inspection

5.1 Lubrication and oil change



Galvanised, semi stainless and stainless electrical products:
Lubrication and oil change. All ball bearings are lubricated with a lubricating grease for the food industry, and all moving parts are treated with a grease for the food industry. The hydraulic system is filled with hydraulic oil of viscosity class ISO VG 32. An additive is added to the oil: - Wynn's Hydraulic Systems Concentrate. The proportion of concentrate is 2.5%, reducing friction and wear and protecting against corrosion. Ready-mixed hydraulic oil with the additive can be bought at the dealers. The oil is suited for use in the temperature range -10°C to +50°C. A thinner oil is recommended for temperatures below -10°C (please contact a dealer).

The hydraulic oil must be changed every other year.

5.2 Oil change



nose
with the

Draining the oil:

1. Bring the forks down to the lowest position.
2. Most of the oil can be drained by loosening the hydraulic union (216) and briefly activating the hydraulic pump switch(122).
3. Remaining oil can be drained from the oil tank by taking off the twelve clips on the pump and removing the tank.

Oil filling:

4. Fill oil through the filling hole (3.5, 4) on the tank.
5. Oil quantity:

EHS 1000/1200	approx. 3 litre
EHS 1000/1400	approx. 3 litre
EHS 1000/1600	approx. 3 litre
6. Refit the filling cap and bleed the system (5.6).

5.3 Fork adjustment

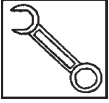

Two of the rollers on the fork bracket are mounted on eccentric pins so that they can be adjusted. The adjustable rollers are upper most.

1. Loosen setscrews pos. 91 (5 mm a/flats).
2. Eccentric pin pos. 56 (8 mm a/flats) can now be turned to give the necessary fork adjustment.
3. Adjustment must be made on both sides to ensure uniform loading of the rollers.

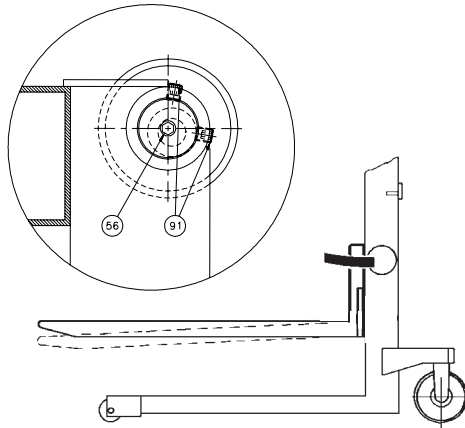

5.4 Adjustment of lifting chain



The chains shall be adjusted so that they lift equally. Shall be equally tight. Adjustment are made on nuts, pos. 18 (nut M12, key width 19 mm).

With straddle versions, chains keep the forks clear of the floor.

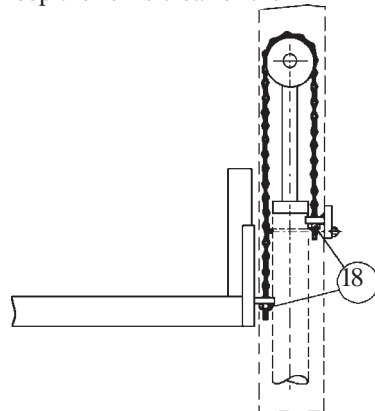

5.5 Adjustment of steer wheel chain



Access to the chain is gained by removing the chain guard.

-Remove the two screws (111) and two screws(110)

(4 mm Allen key).

-Set the handle in its mid position.

-Adjust nuts (1 and 2, 3 and 4) and bring the wheels into parallel.

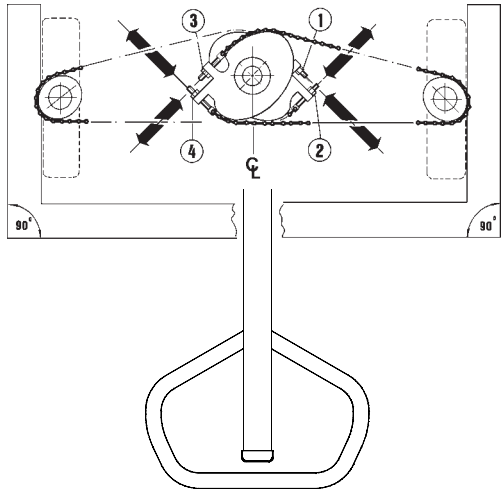
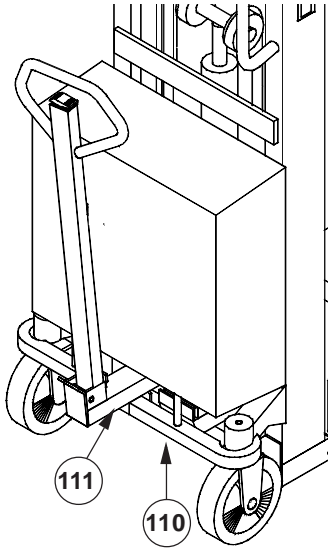

5.6 Bleeding the hydraulic system

With a load of 50-100 kg, the forks must be raised and lowered to top and bottom position 2-3 times.

5.7 Cleaning

The product should not be cleaned with cleaning materials too frequently, as this can lead to corrosion on the galvanised parts. The electric parts on these products are protected against moisture, but do not stand direct contact with water.

Switches and other external parts are enamelled, so that they can stand moisture.

When cleaning the stacker, do not direct the jet onto bearings and seals. Otherwise the grease will be washed out and the life of the equipment shortened.

6.0 Good service after purchase



6.1 Ordering spare parts

The correct spare parts are obtainable from your dealer.

When ordering, please state:

- Serial number of the product
- Type and width/length of the product
- Spare part no.

Please find spare part no. in the Instruction Manual or on [www. logitrans.com](http://www.logitrans.com) under Support.

6.2 Warranty/Compensation

Spare parts delivered during the warranty period will be invoiced. A credit note will be sent immediately after we have received and tested the defective parts and found that the warranty conditions have been met.

6.3 Service and repair

You should be able to make adjustments and perform minor repairs on the spot. However, major repairs should be left to the dealer who has well-trained personnel and the necessary special tools. The manufacturer has an exchange system for pumps/cylinders. These are renovated and delivered with warranty.

6.4 Warranty

The warranty covers material and assembly defects which, subject to inspection by us or our representative, are deemed to be faults or deficiencies that prevent normal use of the parts concerned. Such affected parts shall be sent to your Logitrans dealer carriage paid within the warranty period in force at the time in question, together with a copy of the documentation for the service performed (B284 - see the back page).

- The warranty does not cover normal wear and adjustments.
- The warranty period is based on singleshift working.

The warranty shall no longer apply if

- the product has been used incorrectly,
- the product is used in environments for which it was not designed,
- the product has been overloaded,
- replacements of parts have been made incorrectly or original parts have not been used and consequential damages have arisen,
- if the product is changed or accessories, not being approved by Logitrans, are used.
- it can not be proved that a qualified technician has performed the service check according to the requirements stated in the instruction manual (see the back page).

6.5 Liability exemption

The manufacturer accepts no responsibility for personal injury or material damage arising from deficiencies, defects or improper usage. The manufacturer accepts no responsibility for lost earnings, operating losses, lost time, lost profits or similar indirect losses incurred by the purchaser or a third party.

7.0 The advantages of stainless

7.1 Corrosion

Details are contained in the spare parts lists.

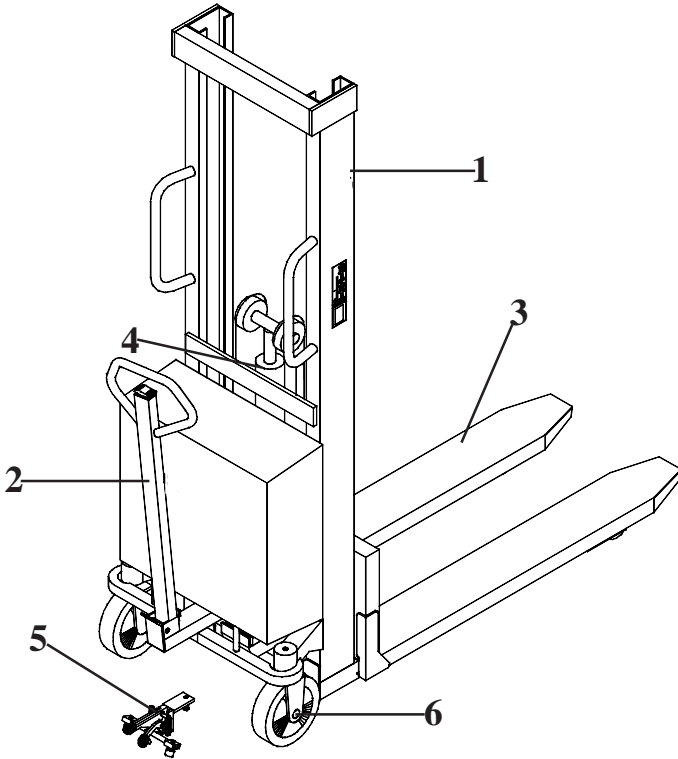

- 1. Chassis
- 2. Handle
- 3. Fork bracket
- 4. Cylinder (1)
- 5. Brake
- 6. Shafts

RF-SEMI

A	B	C	D
	X		
	X		
X			
			X
			X
X			

Material code

A	Acid-resistant steel AISI 316
B	Stainless steel AISI 303/304
C	Hot-dip galvanised - coating thickness: min. 50 µm
D	Electrogalvanised + yellow chromated - coating thickness: 6-10 µm. - This surface treatment has good properties in respect of wear, water and chemical resistance. However, it is important to be aware that if certain parts are subjected to shock and impact the coating can crack and thus allow corrosive substances to affect base materials.

(1) The cylinder is not made of stainless material, but is surface treated (D).

The Piston rod is stainless.

Under certain circumstances, corrosion can appear on parts of the cylinder.

7.2 Warranty

Rust damage in the cylinder, pump or electrical parts and tarnishing on the stacker caused by the environment in which it is used or the way it is cleaned are not covered by the warranty.

See point 6.4 "Warranty conditions".

8.0 Fault location key

When the STACKER is used every day, adjustments and the replacement of worn parts might be necessary.

If a fault appears during daily operation of the highlifter, first check:

- Oil supply
- Electricity supply
- Condition of leads and fuses

If faults cannot be traced to these sources, contact your distributor, but ...

BEFORE ASKING THE DISTRIBUTOR FOR ASSISTANCE...

...TRY THE FAULT LOCATION KEY!

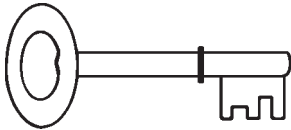

SYMPTOMS AND OBSERVATIONS

- A Pump does not run when the UP button is pressed
- B Truck does not lift when the UP button is pressed
- C Truck does not lift to max. height
- D Forks fall after being raised
- E Forks do not fall when DOWN button is pressed
- F Forks cannot be lowered fully
- G Truck unable to lift the max. load
- H Truck lifts slowly
- I Forks do not lift horizontally
- J Steer wheel does not drive evenly

Cause

Mending

	<u>Oil deficiency</u>	See point 5.1/ 5.2
	<u>Battery discharged</u>	See point 4.3
	<u>Fuse blown</u> Point 3.5 pos. A1/A2	See point 3.5/ 4.5
	<u>Leads defective</u>	See point 4.6
	<u>Max. load exceeded</u>	See point 3.1
	<u>Air in hydraulic system</u>	See point 5.6
	<u>Pressure relief valve incorrectly adjusted</u> Point 3.5 pos. B	Contact the distributor
	<u>Hyd. hose defective</u> Point 3.5 pos. 3	Contact the distributor
	<u>Mast needs adjustment</u>	See point 5.3/ 5.4
	<u>Valve damaged</u> (solenoid and check valve) Point 3.5 pos. 1 and 2	Contact the distributor
	<u>Defective valves in pump</u>	Contact the distributor
	<u>Steer wheel out of adjustment</u>	See point 5.5
A	● ● ●	
B	● — — — ● ● ●	
C	● — — — — — — —	
D	— — — — — ● ●	
E	● ● ● — — — — ●	
F	— — — — — — — ●	
G	— — — — — ● — — —	
H	● — — — — — — ●	
I	— — — — — ● — — —	
J	— — — — — — — ●	

If the problem cannot be solved by using the fault location key...
...please contact your distributor!

Periodic service check

Service check is required once each year.

The service check is to be performed on the basis of form no. B280 and proved on form no. B284. Forms and instructions for the service check are available at your dealer.

Periodic safety inspection

Safety inspection should be performed by the dealer or other qualified persons at least once each year, unless local regulations state otherwise.

The safety inspection to be performed on the basis of form no. B278 and proved on form no. B284. Forms and instructions for the safety inspection are available at your dealer.