

LOGIFLEX ELF / ELFS

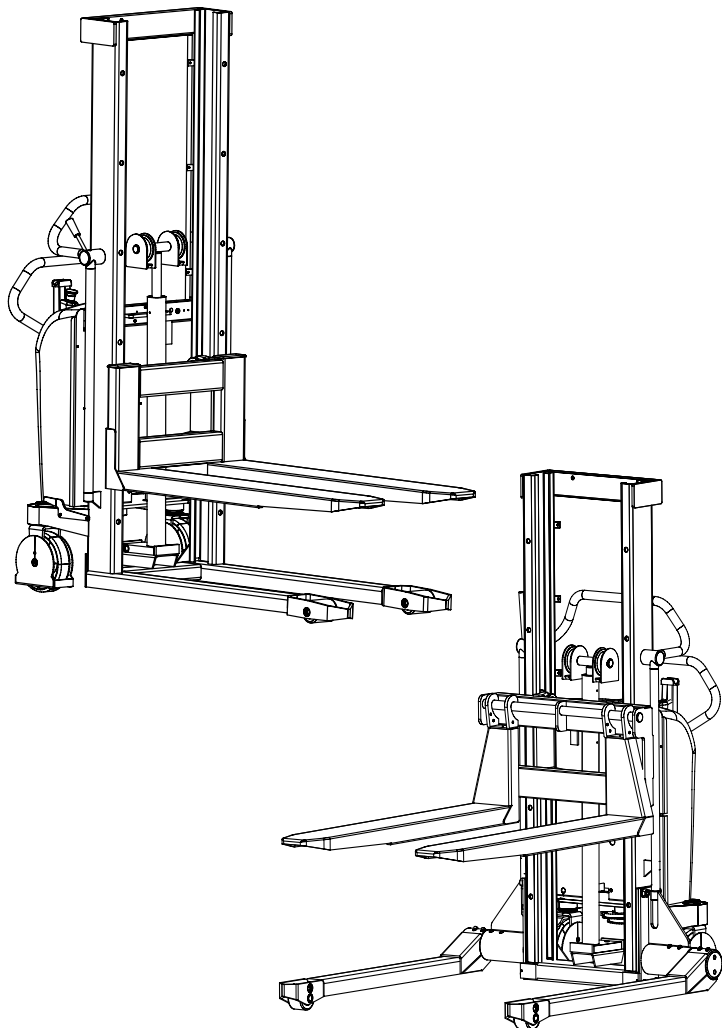

EU DECLARATION CONFORMANCE

Manufacturer: **Logitrans A/S**
Hillerupvej 35
DK-6760 Ribe
Denmark

It is hereby declared that:

Machine: Productgroup: Logiflex

 Type: ELF/ELFS

 Year of manufacture/
 Serial No:

a) Has been manufactured in conformance with the stipulations of the:

- **Directive no. 2006/42/EC**
- **Directive no. 2004/108/EC**
- **Directive no. 2006/95/EC**

b) Has been manufactured in conformance with the stipulations of the standard:

- **EN 1757-1**

Name: **Erling Pedersen**

Position: **Product manager**

Company: **Logitrans A/S**

Signature: 

Product type declaration of:
01.01.2010



Contents

1.0 Before the first lift...	4
2.0 Functions and identifications	5
3.0 How to operate the Logiflex	6
3.1 Handling of pallets	6
4.0 Optimum safety	7
4.1 Avoid overloads	8
4.2 Avoid offset loads	8
4.3 Driving loaded	9
4.4 Emergency braking and emergency stop	9
5.0 There must be a current supply...	10
5.1 Fuses - replacement	10
5.2 Wiring connections	10
6.0 Long live the Logiflex	11
6.1 Lubrication and hydraulic oil	11
6.2 Oil change	11
6.3 The hydraulic pump	12
6.4 Fork adjustment	12
6.5 Adjustment of lifting chain	12
6.6 Adjustment of steering wheel chains	13
6.7 Adjustment of side play	13
6.8 Cleaning	14
7.0 Good service after purchase	15
7.1 Ordering spare parts	15
7.2 Warranty/Compensation	15
7.3 Service and repair	15
7.4 Warranty	15
7.5 Liability exemption	15
8.0 Fault location key	16





1.0 Before the first lift...

The Logiflex is manufactured in accordance with safety directives.

Among the subjects dealt with in this **Instruction Manual** are:



- Proper application
- Physical limitations of the product
- Risks with improper use

Therefore please read this Instruction Manual carefully!

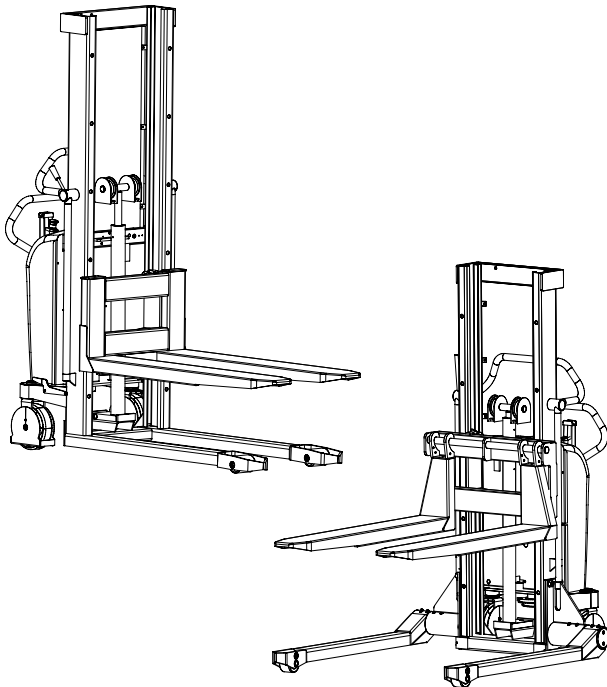



2.0 Functions and identifications

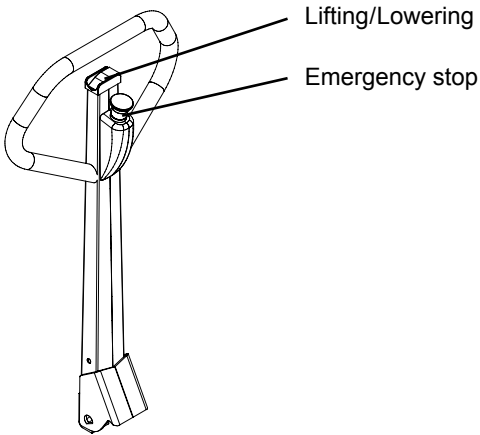

Released

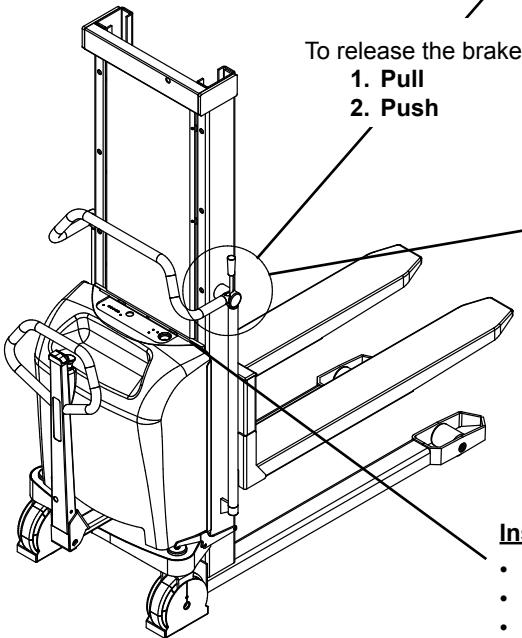
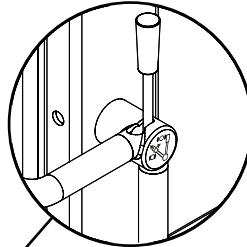

Braked position

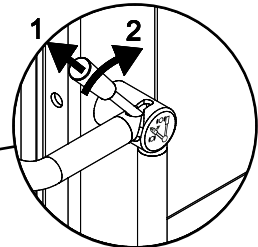

Instrument board:

- Battery indicator
- Type plate
- Charging plug (internal or external charger)
- Plug for extra equipment, 12V maximum 15 Amp



3.0 How to operate the Logiflex

3.1 Handling of pallets

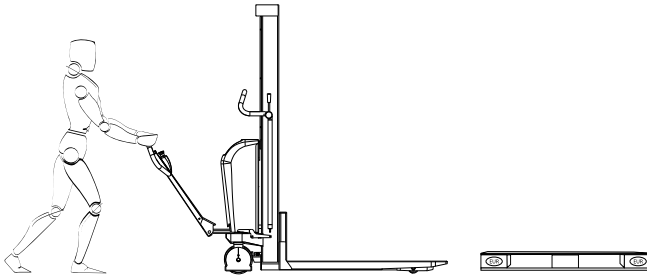

For proper operation,
stand behind the handle.

Push/pull - raise/lower.

The forks will lift 190 mm
before the telescopic mast begins
to extend.

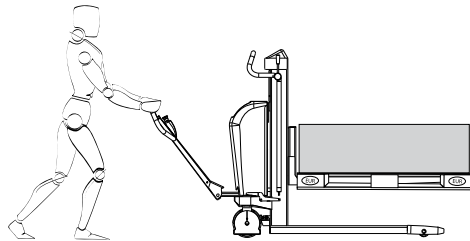

Applies to:

ELF 2050 - 3300

ELFS 2020 - 3270

ELFS

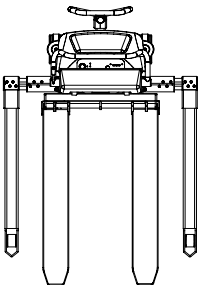

When handling closed pallets...

- Use the straddle Logiflex!

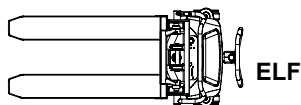
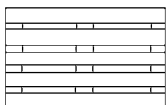



4.0 Optimum safety



ATTENTION
Moving parts

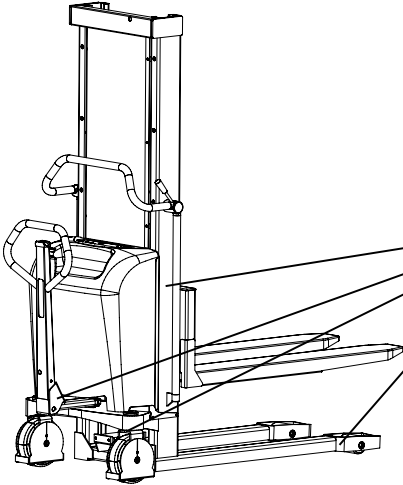

Safety regulations

- Never walk under a raised load!
- Before lowering the forks, make certain that no foreign elements can hinder the free lowering of the forks
- The Logiflex is designed for use on an even and level floor
- During transport the forks shall be raised as little as possible
- Transport with raised forks should be made over the shortest possible distances and at low speed
- Check that the chains lift equally. They shall be equally tight when the forks are loaded
- Chains and chain bolts must not be damaged. Chains that have become permanently stretched (max. 2 % of original length) must be scrapped.



4.0 Optimum safety

4.1 Avoid overloads

The maximum load must not be exceeded. **Remember**, that the Logiflex is designed for evenly distributed load, - goods on pallets etc. If the forks are point-loaded on one side, there is a risk of bending.

4.2 Avoid offset loads

The load must be evenly distributed. The maximum centre of gravity distance from the front of the fork mast (given on the truck) must not be exceeded. A greater distance reduces the level of safety and increases the risk of toppling.

Goods on pallets, etc. must be properly secured, so that they cannot fall off during transport, when the truck is lifted, or when the truck must remain lifted for a time.

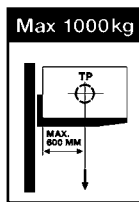
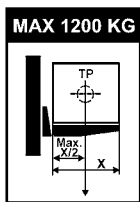

Marking

The mast lifting capacity and the corresponding centre of gravity distance are given by the pictogram on the side of the mast.

The lifting capacity of the mast is the same as the max. lifting capacity of the product.

Max. lifting capacity is set on the safety valve of the product.

NOTE! If the Logiflex is fitted with optional extras, the capacity of the optional extras will apply.

Specific to ELF 1001/3300 - with load limitation at significant lifting heights.

- The fork bracket loading is dependent on the lifting height and can be read on the load diagram.
- Load limitation at significant heights is incorporated to give *greater stability of the Logiflex and operator safety.*

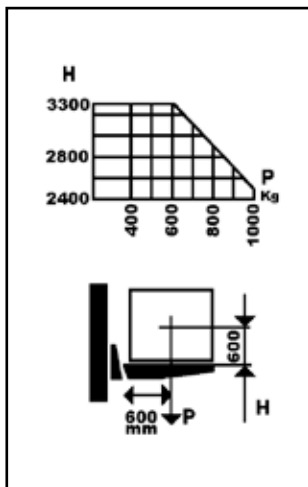

4.0 Optimum safety

4.3 Driving loaded

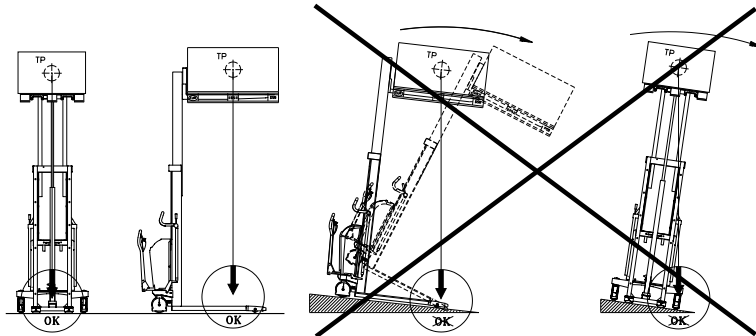

The Logiflex is designed for use on even and level floor. During transport the forks shall be raised as little as possible. Transport with raised forks should be made over the shortest possible distances and at low speed.

4.4 Emergency braking and Emergency stop

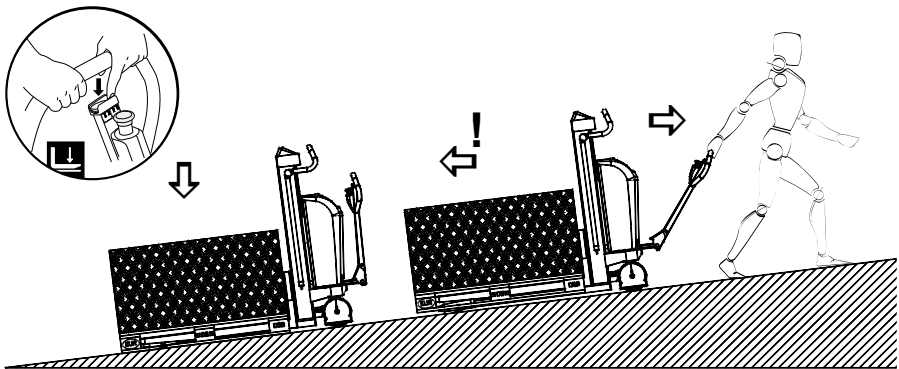

If it becomes necessary to use the load as a brake to prevent the Logiflex from running away, activate the DOWN button quickly, until the load reaches the ground.

The product has an emergency stop. When activating the emergency stop, the main current supply is switched off. The movement of the forks stops immediately when activating the emergency stop.

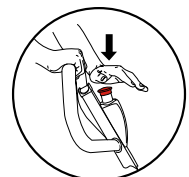

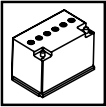

5.0 There must be a current supply...

5.1 Fuses - replacement

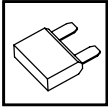

There are four fuses in the electrical circuit.

- 80 Amp fuse in the main supply from battery
- 5 Amp fuse in the control current circuit
- 15 Amp fuse (plug for extra equipment on the instrument board)
- 30 Amp fuse for built-in charger

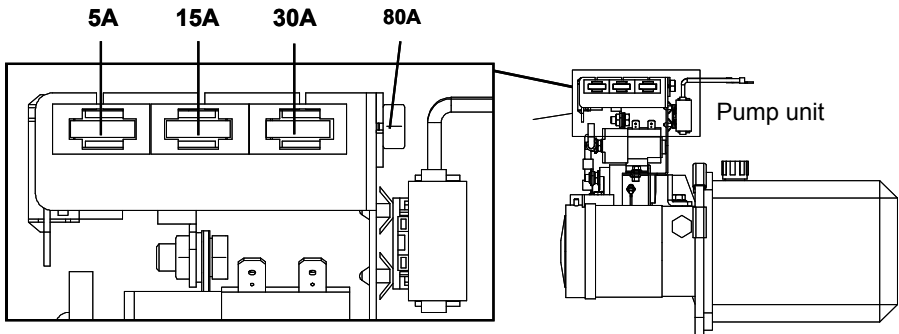

Replacement:

The old fuse is to be removed and replaced by a new one of the same size. Do not use a bigger fuse, as the fuse works as protection of the electric circuit.

Find out why fuses blow!

5.2 Wiring connections

Many operational disturbances are caused by bad connections in the electrical circuit. Make sure that the connections are in order.

Check connections regularly for damage at insulating caps or bad connections at plugs, etc.

Verdigris must be removed from cable plugs. Keep all screw/nut connections tight.



6.0 Long live the Logiflex

Regular inspection and the replacement of worn or defective parts in good time will prolong the life of the Logiflex.

“Prevention is better than repair”, therefore ensure:

- Correct usage
- Regular cleaning
- Periodic safety and service inspection

6.1 Lubrication and hydraulic oil



Under normal operation conditions the Logiflex requires no lubrication.

All ball bearings are sealed and lubricated for life, and moving parts have self-lubricating bearings or are treated with grease. The hydraulic system is filled with hydraulic oil of viscosity class ISO VG 15.

An additive is added to the oil. The concentrate reduces friction and wear and protects against corrosion.

Pre-mixed hydraulic oil with additive is available from the dealer. The oil is suitable for use in the temperature range -10 to +50° C. A thinner oil is recommended for temperatures lower than -10° C (if necessary, contact your dealer).

6.2 Oil change

Draining the oil:

1. Bring the unloaded forks down to the lowest position.
2. Most of the oil can be drained by loosening the hydraulic hose union and briefly activating the hydraulic pump with the switch.
3. The remaining oil can be drained from the oil tank by taking off the twelve clips on the pump and removing the tank.

Oil filling:

4. Fill oil through the filling hole on the tank.

5. Oil quantity:

ELF 920 & ELFS 890	Approx 1,5	Liter
ELF 1200 - ELF 1600 & ELFS 1170 - ELFS 1570	Approx 3,0	Liter
ELF 1910 - ELF 2850 & ELFS 1880 - ELFS 2820	Approx 4,0	Liter
ELF 3300 & ELFS 3270	Approx 4,5	Liter

6. Refit the filling cap and bleed the system (6.3).

6.0 Long live the Logiflex

6.3 The hydraulic pump

The hydraulic pump has a S3 “periodic intermittent duty” of 10 %. This means that the pump in total is allowed to operate 1 minute for a period of 10 minutes. If the pump operates more than 10%, the motor will be damaged due to superheating.

Bleeding the hydraulic system

With a load of 50-100 kg, the forks must be raised and lowered to top and bottom position 2-3 times.

6.4 Fork adjustment

Two of the rollers on the fork bracket are mounted on eccentric pins, so that they can be adjusted. The adjustable rollers are at the top.

1. Loosen screw (pos. 91) (key width 5 mm).
2. Eccentric pins (pos. 56) (key width 8 mm) can now be turned to give the necessary fork adjustment.
3. Adjustment must be made on both sides to ensure uniform loading of the rollers.

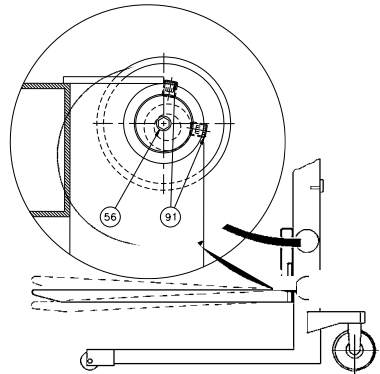

6.5 Adjustment of lifting chain

The chains shall be adjusted so that

- they lift equally
- they are equally tight
- The lifting movement has to stop in the cylinder, before the mast rolls touch the top stop.

After adjusting, please check:

- a: Fork bracket: the forks have to be placed above the wheels
- b: Adjustable carriage: the forks are to be kept clear of the floor

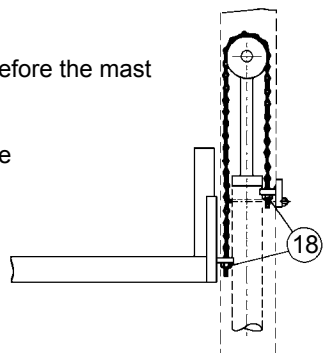

The nuts (pos. 18) are to be adjusted (nut M12, key width 19 mm).

6.0 Long live the Logiflex

6.6 Adjustment of steering wheel chains

- Set the handle in its middle position
Adjust the nuts (1, 2, 3 and 4) and bring the wheels into parallel.

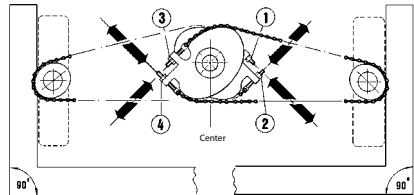

6.7 Adjustment of side play (In the mast rolls of the right side of the fork bracket)

1. Screw (A) is loosened counter-clockwise, until resistance disappears.
2. Turn the screw clockwise, until resistance appears. The following 1.5 to 2.5 turns of the screw will be a tightening of the spring (C).
3. When a larger resistance appears, make 0.25 turn counter-clockwise, and the counter nut (B) will be tightened.
4. Pump the forks to its top position, and when lowering it has to slide to the bottom. If this is not the case, loosen screw A, make approx. 0.5 turn counter-clockwise and repeat point 4.

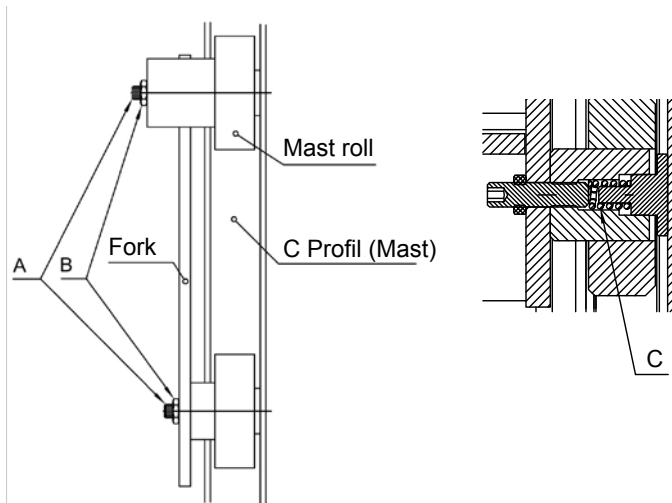

6.0 Long live the Logiflex

6.8 Cleaning



When cleaning the Logiflex, do not direct the jet onto bearings and seals. Otherwise the grease will be washed out and the life of the equipment shortened.

Cleaning of the plastic screen (polycarbonate)

The screen is to be washed with slightly warm water added a neutral cleaning material, and afterwards washed with clean water.

Use a soft sponge, a woollen cloth or a wash leather.



Never use sharp objects or solvent cleaners when cleaning.



7.0 Good service after purchase

7.1 Ordering spare parts

The correct spare parts are obtainable from your dealer.

When ordering, please state:

- Serial number of the product
- Type and width/length of the product
- Spare part no. Please find spare part no. on **www. logitrans.com**.

7.2 Warranty/Compensation

Spare parts delivered during the warranty period will be invoiced. A credit note will be sent immediately after we have received and tested the defective parts and found that the warranty conditions have been met.

7.3 Service and repair

You should be able to make adjustments and perform minor repairs on the spot. However, major repairs should be left to the dealer who has well-trained personnel and the necessary special tools.

7.4 Warranty

The warranty covers material and assembly defects which, subject to inspection by us or our representative, are deemed to be faults or deficiencies that prevent normal use of the parts concerned. Such affected parts shall be sent to your Logitrans dealer carriage paid within the warranty period in force at the time in question, together with a copy of the documentation for the service performed (B284 - see the back page). The warranty does not cover normal wear and adjustments. The warranty period is based on singleshift working.

The warranty shall no longer apply if

- the product has been used incorrectly,
- the product is used in environments for which it was not designed,
- the product has been overloaded,
- replacements of parts have been made incorrectly or original parts have not been used and consequential damages have arisen,
- if the product is changed or accessories, not being approved by Logitrans, are used.
- it can not be proved that a qualified technician has performed the service check according to the requirements stated in the instruction manual (see the back page).

7.5 Liability exemption

The manufacturer accepts no responsibility for personal injury or material damage arising from deficiencies, defects or improper usage. The manufacturer accepts no responsibility for lost earnings, operating losses, lost time, lost profits or similar indirect losses incurred by the purchaser or a third party.



8.0 Fault location key

When the Logiflex is used every day, adjustments and the replacement of worn parts might be necessary.

If a fault appears during daily operation of the LOGIFLEX, first check:

- Oil supply
- Electricity supply
- Condition of leads and fuses

If faults cannot be traced to these sources, contact your dealer, but...



**Before asking the dealer for assistance...
...try the fault location key!**

Symptoms and observations

- A** Pump does not run when the UP button is pressed _____
- B** Truck does not lift when the UP button is pressed _____
- C** Truck does not lift to max. height _____
- D** Forks lower after being raised _____
- E** Forks do not lower when DOWN button is pressed _____
- F** Forks cannot be lowered fully _____
- G** Truck unable to lift the max. load _____
- H** Truck lifts slowly _____
- I** Forks do not lift horizontally _____
- J** Steering wheel does not drive evenly _____

Cause

Mending

	Oil deficiency	See point 6.1/6.2
	Battery discharged	See separate manual
	Fuse blown 5Amp or 80Amp	See point 5.1
	Cables defective	See point 5.2
	Max. load exceeded	See point 4.1
	Air in hydraulic system	See point 6.3
	Pressure relief valve incorrectly adjusted	Contact the dealer
	Leakage in hydraulic system Visible oil leakage	Contact the dealer
	Fork bracket needs adjustment	See point 6.4/6.5/6.7
	Solenoid or check valve defective	Contact the dealer
	Defective valves in pump	Contact the dealer
	Steering wheel out of adjustment	See point 6.5
	Defective solenoid valve	Contact the dealer
	<p>If the problem cannot be solved by using the fault location key...</p> <p>...please contact your dealer!</p>	
A	● ● ●	
B	● ● ● ● ●	
C	●	
D		● ●
E	● ● ●	●
F		●
G		●
H	●	●
I		●
J		●

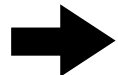

Periodic service check

Service check is required once each year.

The service check is to be performed on the basis of form no. B280 and proved on form no. B284. Forms and instructions for the service check are available at your dealer.

Periodic safety inspection

Safety inspection should be performed by the dealer or other qualified persons at least once each year, unless local regulations state otherwise.

The safety inspection to be performed on the basis of form no. B278 and proved on form no. B284. Forms and instructions for the safety inspection are available at your dealer.

S 612

ELF-L-EN

01012010