

## SPARE PARTS LIST

### Logitrans Mover LM1500

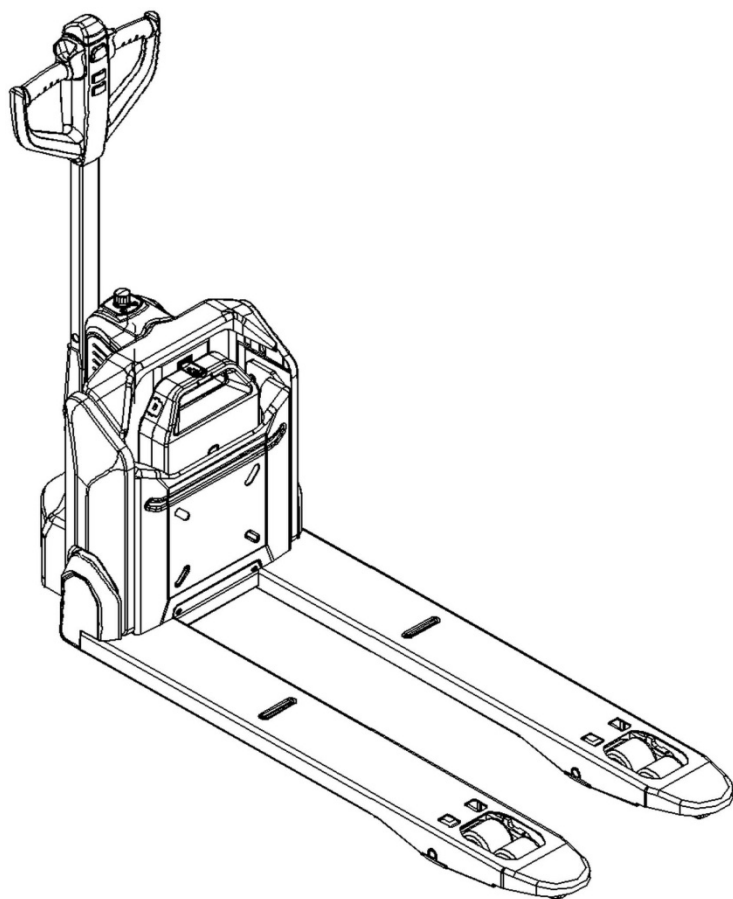

Version 05/2019

LM1500



# Index

Fig. 1 Chassis (540x1150).....	4
Fig. 2 Chassis (685x1220).....	6
Fig. 3 Load roller components .....	8
Fig. 4 Driving unit.....	10
Fig. 5 Driving wheel components .....	12
Fig. 6 Cylinder.....	13
Fig. 7 Power unit.....	14
Fig. 8 Hydraulic components .....	15
Fig. 9 Steering wheel components (with side rollers).....	16
Fig. 11 Tiller head.....	17
Fig. 12 Tiller arm components .....	19
Fig. 13 Truck components .....	20
Fig. 14 Power supply assembly.....	22
Fig. 15 Controller components .....	23
Fig. 17 Charger .....	25
Fig. 18 Wiring harness.....	26

Fig. 1 Chassis (540x1150)

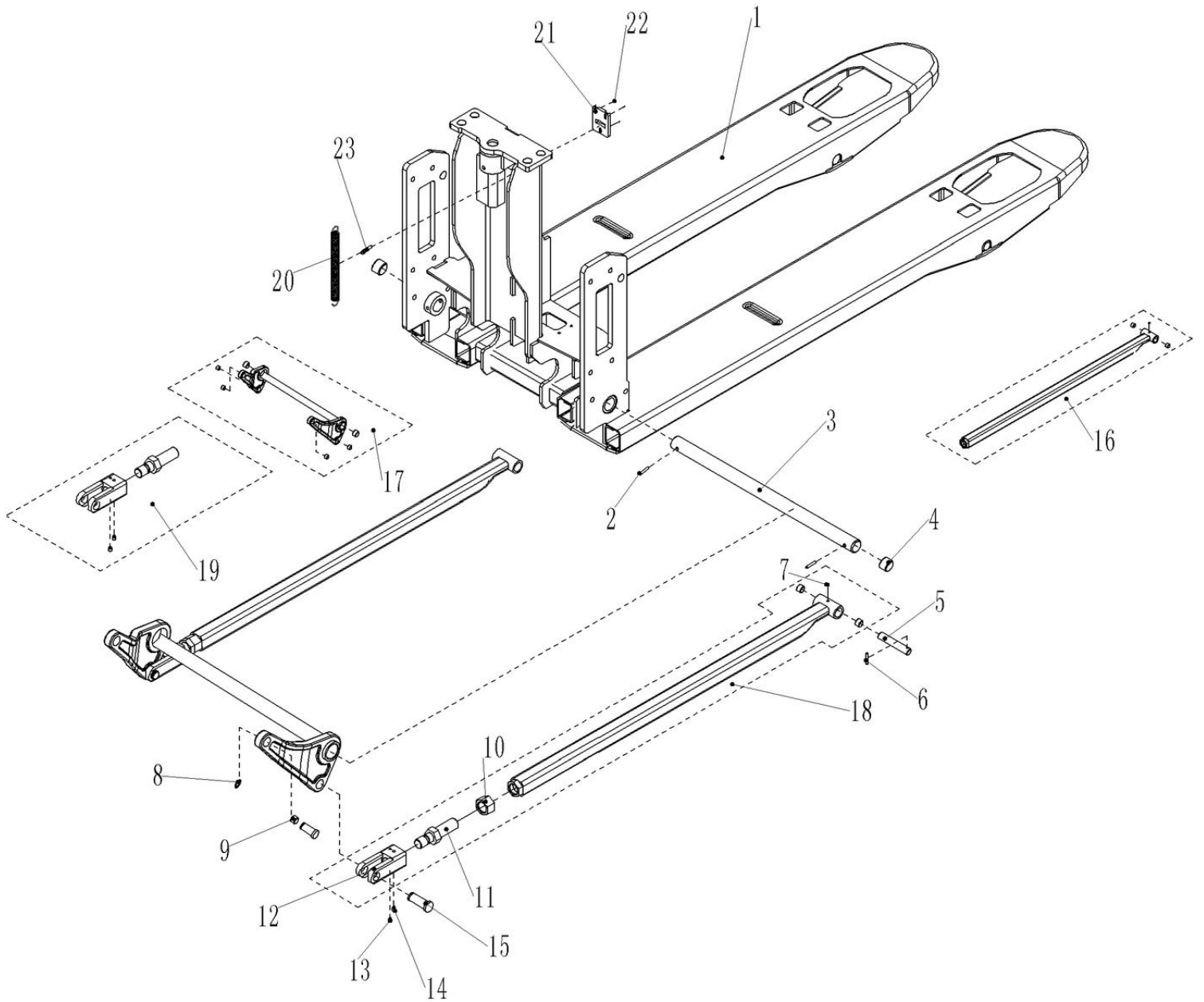

**Fig. 1 Chassis (540x1150)**

No.	Art No.	Description	Qty.	Note
1		Chassis welding (540x1150)	1	
2		Elastic cylindrical pin GB879.1-6x40	2	
3		Axle $\Phi$ 24.6x462	1	
4		Bushing $\Phi$ 24.6x $\Phi$ 29x25- SF-1(with grease hole)	2	
5	502338520030	Push rod axle $\Phi$ 16x82	2	
6		Elastic cylindrical pin GB879.1-5x28	2	
7		Grease nipple JB7940.4-6	2	
8		Circlip GB894.1-16	4	
9		Bushing $\Phi$ 16x $\Phi$ 18x15-SF- 1(with grease hole)	8	
10		Nut GB6173-M20x1.5-05	2	
11		Adjusting bolt	2	
12		Push rod fork	2	
13		Screw GB79-M6x8-45H	2	
14		Elastic cylindrical pin 4x30	2	
15	508038520041	Pin $\Phi$ 16x44	4	
16		Push rod components	2	1150
17		Rock arm components (540)	1	
18	508098510002	Push rod kits (1150)	2	1150
19		Push rod fork components	2	
20	380621520042	Spring $\Phi$ 10.4x $\Phi$ 1.6x160	1	
21		Lock catch	1	
22		Screw GB818-M4x8-4.8	3	
23		Bolt GB798-M6x20-5.6	2	

**Fig. 2 Chassis (685x1220)**

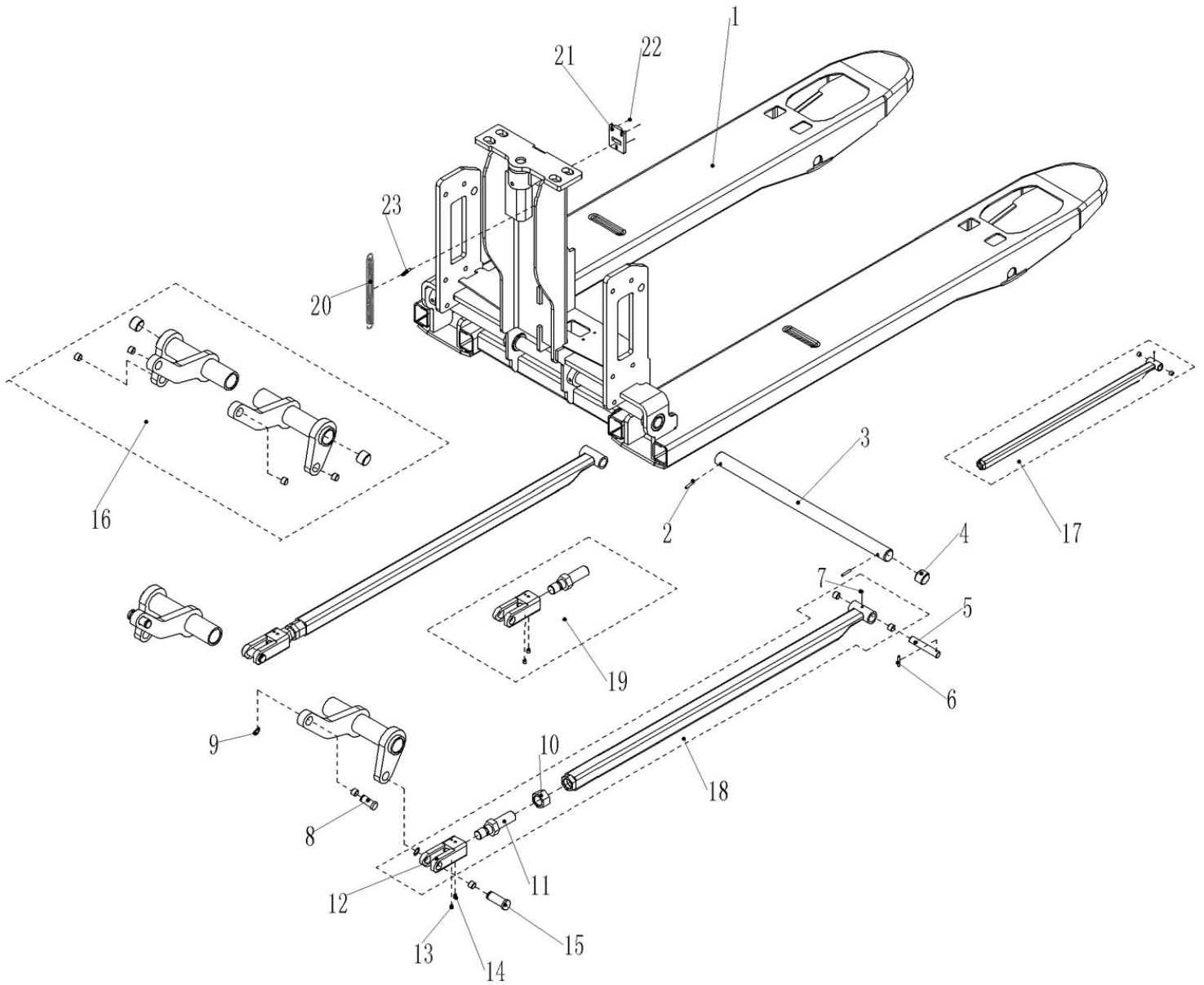

**Fig. 2 Chassis (685x1220)**

No.	Art No.	Description	Qty.	Note
1		Chassis welding (685x1220)	1	
2		Elastic cylindrical pin GB879.1-6x40	2	
3		Axle $\Phi$ 25x609	1	
4		Bushing $\Phi$ 24.6x $\Phi$ 29x25-SF-1(with grease hole)	4	
5	502338520030	Push rod axle $\Phi$ 16x82	2	
6		Elastic cylindrical pin GB879.1-5x28	2	
7		Grease nipple JB7940.4-6	2	
8		Bushing $\Phi$ 16x $\Phi$ 18x15-SF-1(with grease hole)	8	
9		Circlip GB894.1-16	4	
10		Nut GB6173-M20x1.5-05	2	
11		Adjusting bolt	2	
12		Push rod fork	2	
13		Screw GB79-M6x8-45H	2	
14		Elastic cylindrical pin 4x30	2	
15	508038520041	Pin $\Phi$ 16x44	4	
16		Rock arm components (685)	1	
17		Push rod components (1220)	2	1220
18	508098510044	Push rod kits (1220)	2	1220
19		Push rod fork components	2	
20	380621520042	Spring $\Phi$ 10.4x $\Phi$ 1.6x160	1	
21		Lock catch	1	
22		Screw GB818-M4x8-4.8	3	
23		Bolt GB798-M6x20-5.6	2	

**Fig. 3 Load roller components**

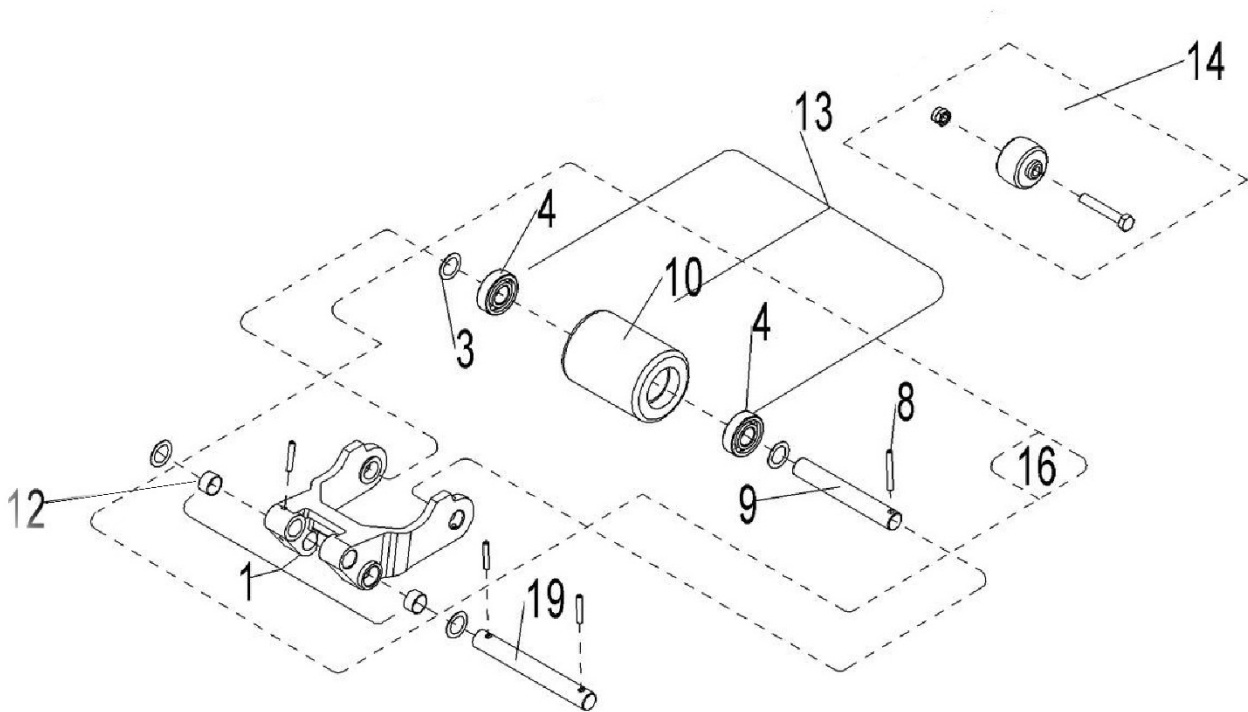
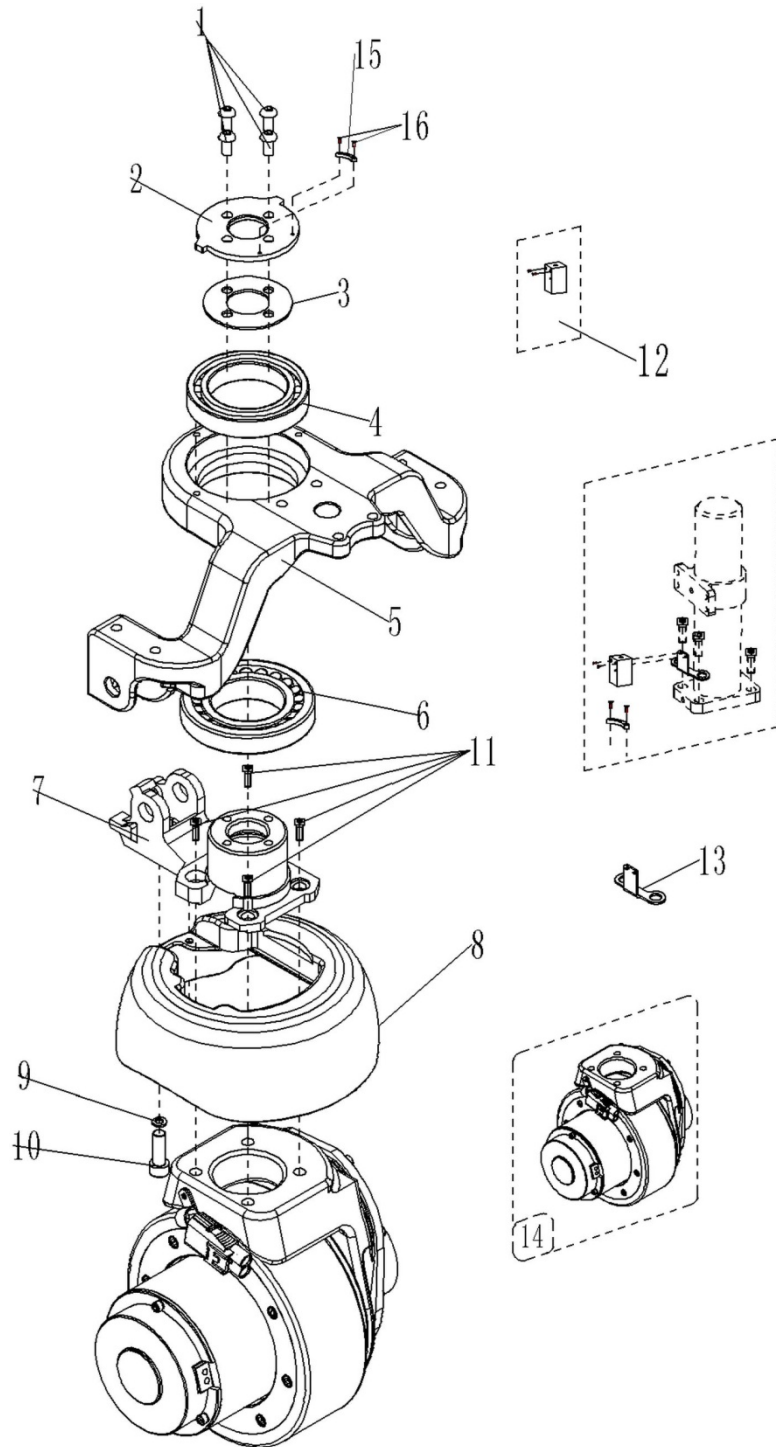



**Fig. 3 Load Roller Components**

No.	Art No.	Description	Qty.	Note
1		Arm block assembly(Single wheel)	2	
3		Washer $\Phi 25 \times \Phi 20.5 \times 1$	4 (Single)	
4		Bearing GB276-6204-2RS	4 (Single)	
8		Elastic cylindrical pin GB879.1-5x35	8	
9		Wheel axle $\Phi 20 \times 122$	2 (Single)	
10		Roller $\Phi 80 \times 93$ (Steel core PU)	2 (Single)	
12		Bushing $\Phi 20 \times \Phi 22 \times 12$ -SF-1(with grease hole)	4	
13	502398510014	Wheel set accessories(single)	2	
14	502398510003	Roller kit	2	
16	508098510050	Wheel accessories(single)	2	
19	508038520030	axle $\Phi 20 \times 158$	2	

Fig. 4 Driving unit



**Fig. 4 Driving Unit**

No.	Art No.	Description	Qty.	Note
1		Screw GB70.2-M8x16-8.8	4	
2		Bearing cap	1	
3		Washer	1	
4		Bearing GB276-6013-2RS	1	
5		Driving wheel seat	1	
6		Bearing GB297-32913	1	
7		Linking flange	1	
8		Round cover	1	
9		Washer GB97.1-6-200HV	2	
10		Screw GB70.1-M6x10-8.8	2	
11		Screw GB70.1-M10x25-8.8	4	
12		Proximity switch components	1	With speed reduction on curve
13		Frame	1	With speed reduction on curve
14		Driving components	1	
15		Induction block	1	
16		Screw GB820-M4x10-4.8	2	

**Fig. 5 Driving wheel components**

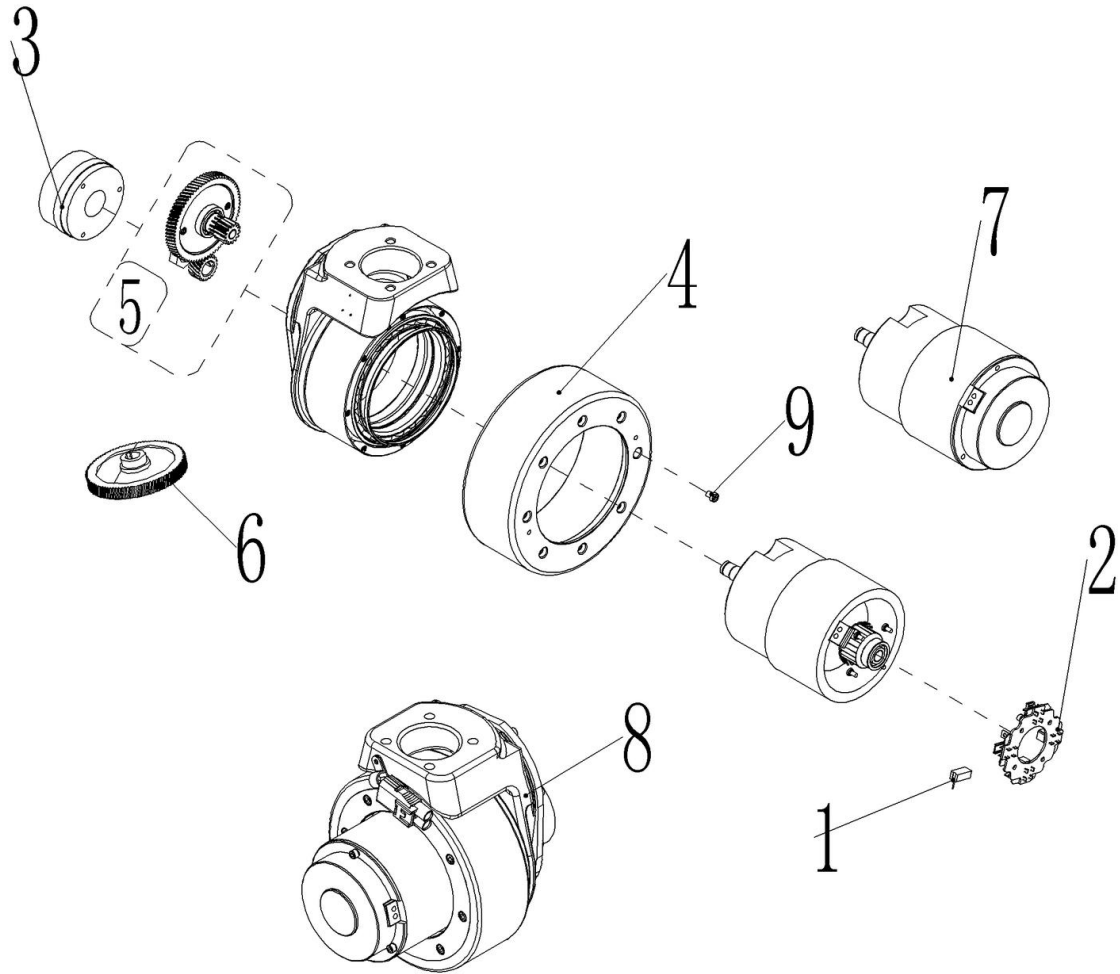

**Fig. 5 Driving Wheel Components**

No.	Art No.	Description	Qty.	Note
1	508098520000	Carbon brush	4	
2	508098520001	Carbon brush frame	1	
3	508098520002	Brake	1	
4	508098520003	Wheel	1	
5		Gearbox components	1	
6		Big gear ring	1	
7	508098510016	Motor components	1	
8		Driving components	1	
9	912620	Screw pad assembly M6	8	

**Fig. 6 Cylinder**

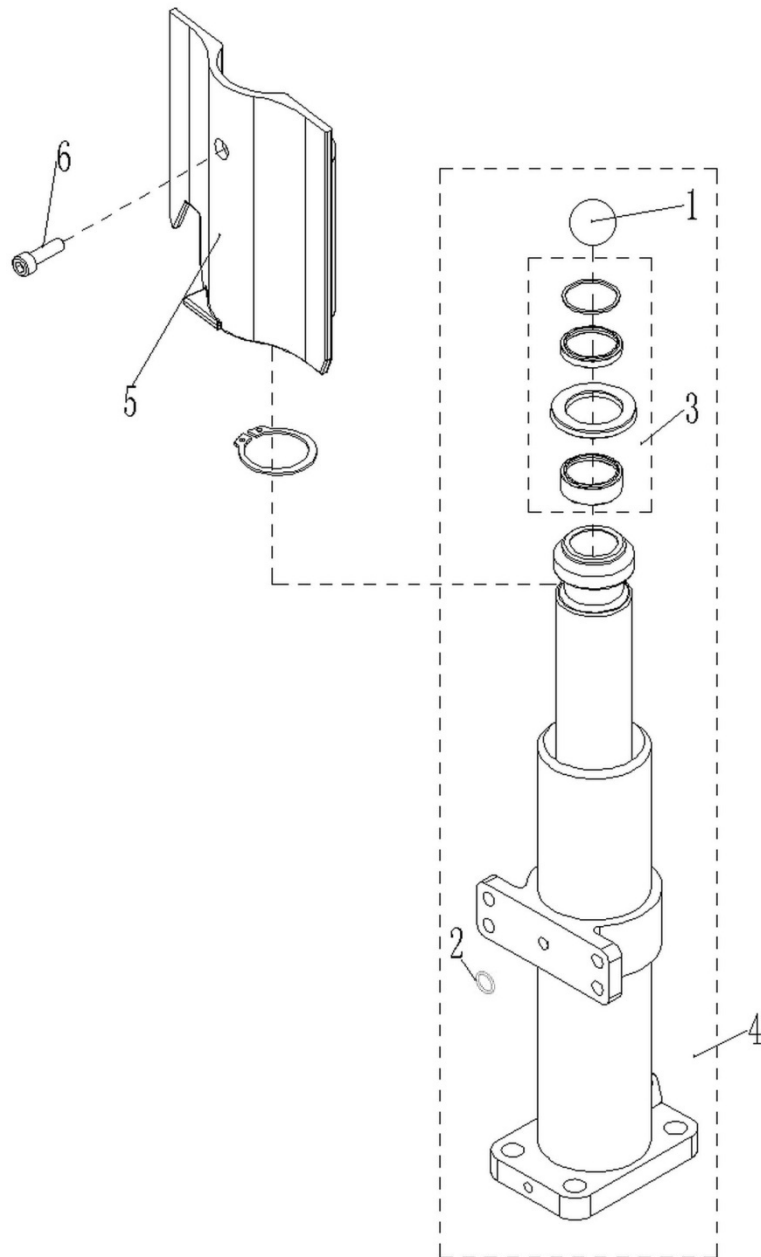

**Fig. 6 Cylinder**

No.	Art No.	Description	Qty.	Note
1	910701100019	Steel ball GB308-18	1	
2	910800100098	O ring	1	13.5x1.8
3	508098510018	Sealing components	1	
4	508098510019	Cylinder components	1	
5		Cover for cylinder	1	
6		Screw GB70.1-M6x12-8.8	1	

**Fig. 7 Power unit**

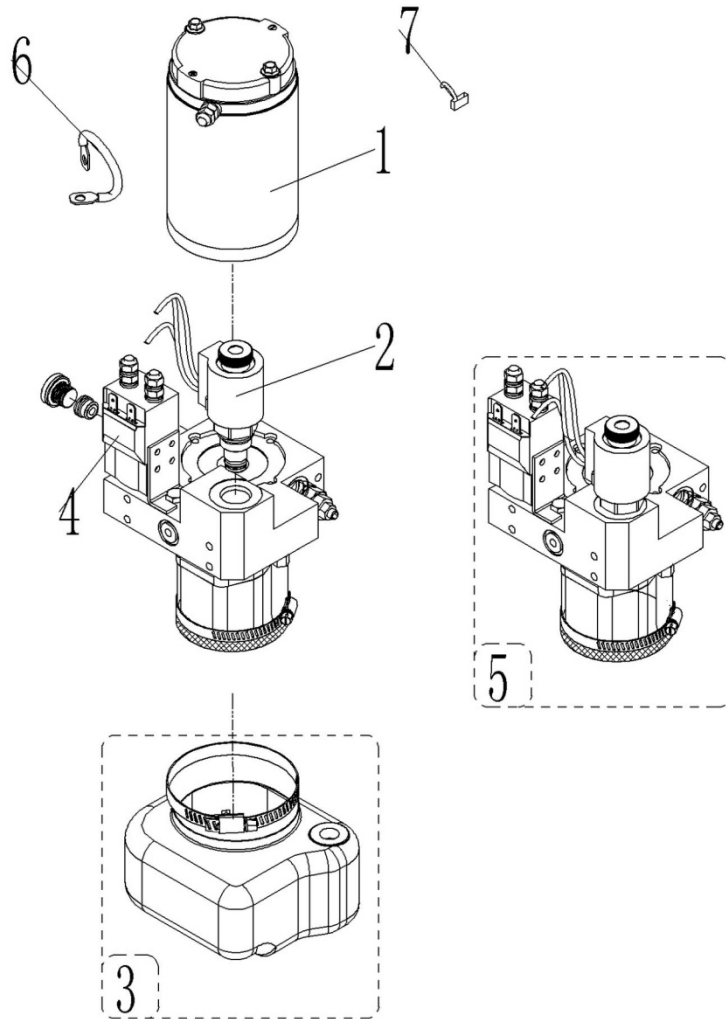

**Fig. 7 Power Unit**

No.	Art No.	Description	Qty.	Note
1	508098510020	DC Motor	1	MD24050
2	508098510034	Electromagnetic valve components	1	
3	508098510023	Oil tank components	1	
4	508098510021	Contactur	1	ZJWP80DE
5		Gear pump components	1	
6		Soft connection cable	1	RSWC-04
7	508098520008	Electric brush	1	

**Fig. 8 Hydraulic components**

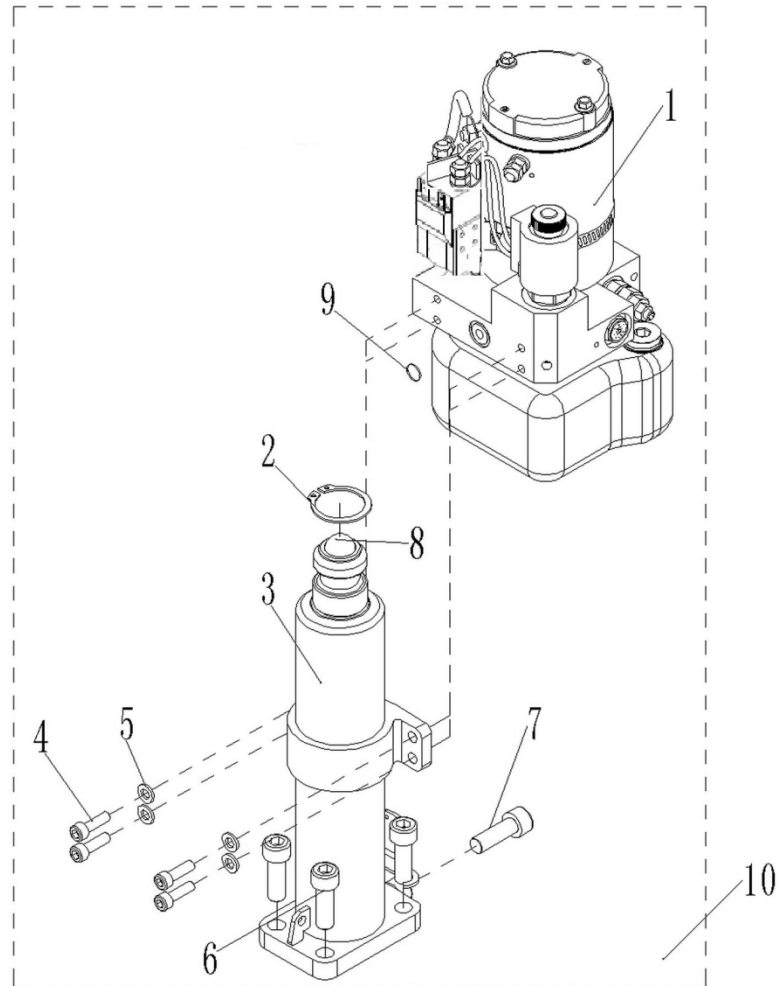

**Fig. 8 Hydraulic Components**

No.	Art No.	Description	Qty.	Note
1	950900100048	Hydraulic power unit 24V0.5KW0.38cc	1	
2	910401300017	Circlip GB894.1-32	1	
3	508024010000	Cylinder assembly	1	
4		Screw GB70.1-M6x20-8.8	7	
5		Flat washer GB97.1-6-200HV	7	
6		Screw GB70.1-M10x30-8.8	4	
7		Screw GB70.1-M6x6-12.9-c1B	1	
8	910701100019	Steel ball GB308-18	1	
9	910800100098	O ring	1	13.5x1.8
10		Hydraulic components	1	

**Fig. 9 Steering wheel components (with side rollers)**

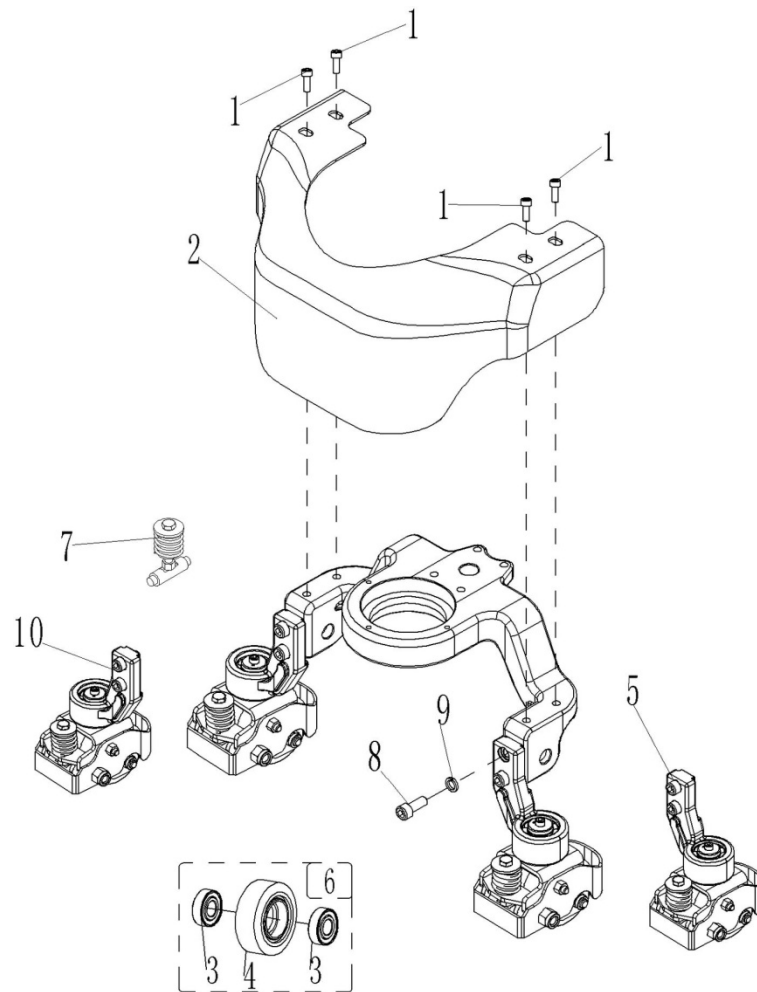
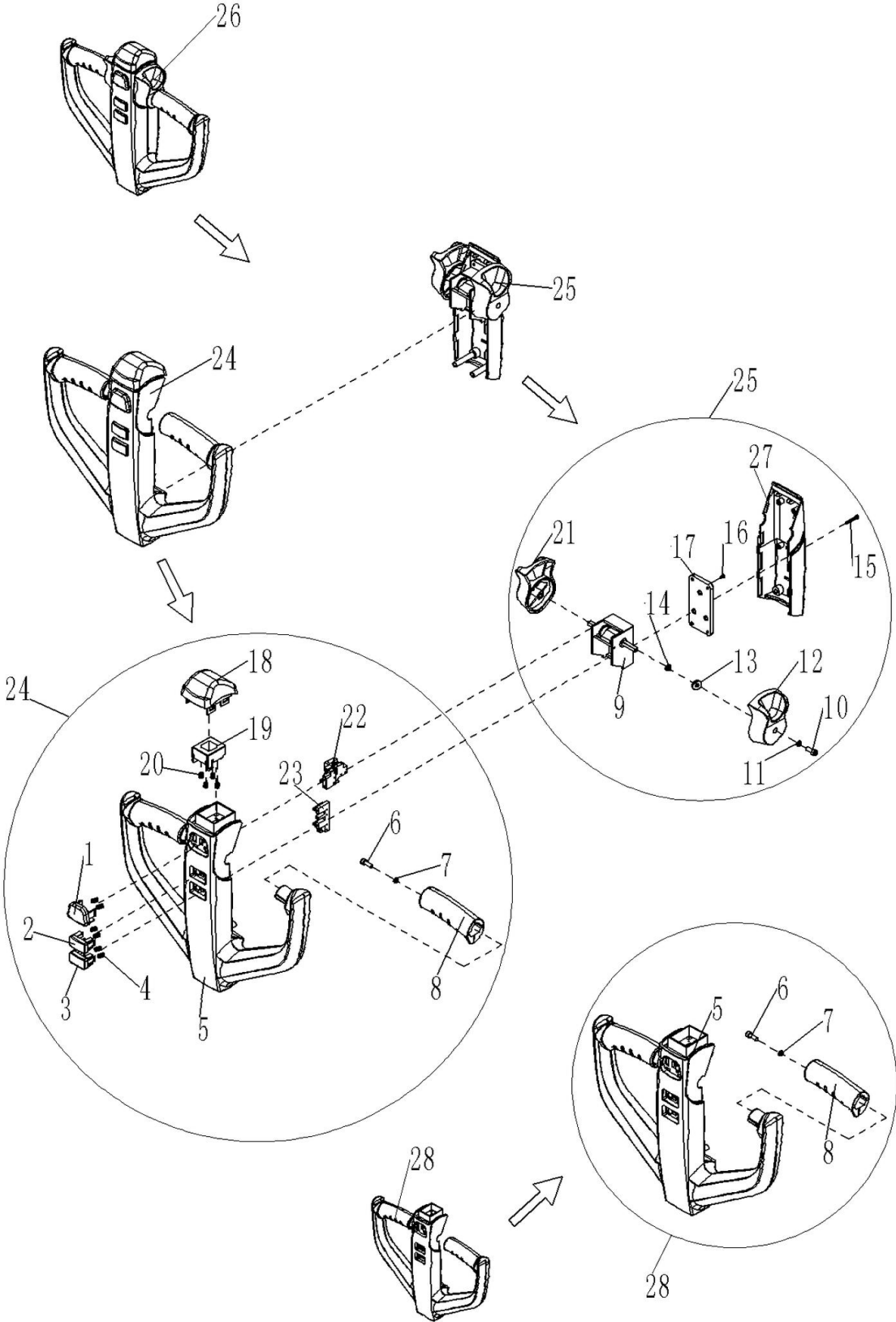

**Fig. 9 Steering Wheel Components (with side rollers)**

No.	Art No.	Description	Qty.	Note
1	941100100005	Screw M10x15-8.8	4	
2		Apron (side roller)	1	Departure altitude: 35mm
				Departure altitude: 45mm
3		Bearing GB276-6203-2RS	2	
4		Roller $\Phi 80 \times 30$ (Steel core PU)	1	
5	508016510005	Side roller components $\Phi 80 \times 30$ (PU/right)	1	
6	502398510015	Roller components	1	
7	508098510047	Spring components	1	
8	910200200076	Screw GB70.1-M10x25-8.8	4	
9	910400100007	Washer GB97.1-10-200HV	4	
10	508016510002	Side roller components $\Phi 80 \times 30$ (PU/left)	1	



Fig. 11 Tiller head



**Fig. 11 Tiller Head**

No.	Art No.	Description	Qty.	Note
1	502398520009	Horn	1	
2	502398520010	Lifting button	1	
3	502398520011	Lowering button	1	
4	502311020022	Spring 0.6	6	Height 16
5		Tiller upper cover	1	
6		Bolt	2	M8*25
7		Washer	2	Φ8
8		Grip	2	
9		Accelerator assembly	1	components
10		Bolt	2	M3*12
11		Washer	2	Φ3
12		Left driving knob	1	
13		Axle external bushing	2	
14		Axle internal bushing	2	
15		Screw GB70.1-M5x50-8.8	2	M5*50
16		Screw	3	M4*6
17		Accelerator fixing plate	1	
18		Belly button base	1	
19		Belly internal base	1	
20		Spring 0.8	4	Height 11
21		Right driving knob	1	
22		Horn micro switch components	1	
23		Lifting and lowering micro switch components	1	
24	508098510031	Tiller upper cover components	1	
25	508098510032	Tiller bottom cover components	1	
26	922100100013	Tiller NL-H300	1	
27		Display panel assembly	1	
28	508098510046	Handle cover fitting	1	

**Fig. 12 Tiller arm components**

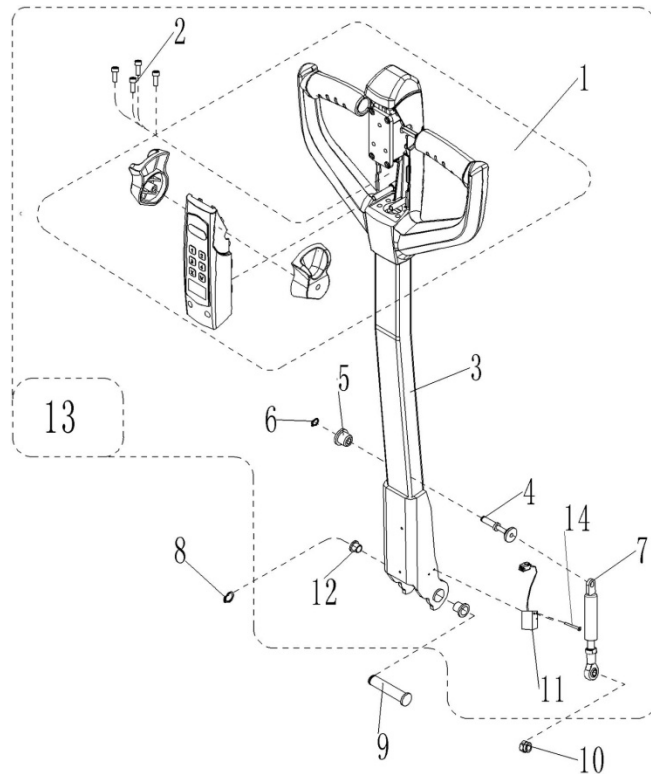

**Fig. 12 Tiller Arm Components**

No.	Art No.	Description	Qty.	Note
1	922100100013	Tiller NL-H300	1	
2		Screw GB70.1-M6x35-8.8	4	
3		Tiller arm welding	1	
4		Fixing axle welding	1	
5		Fixing base	1	
6		Circlip GB894.1-8	1	
7	508011010001	Air spring (D245)	1	
8	910401300006	Circlip GB894.1-15	1	
9	508011020004	Pin $\Phi 15 \times 70$	1	
10		Screw GB70.1-M8x20-8.8	1	
11	505633510002	Proximity switch NBN5-F7-E2(800mm)	1	
12	940500200001	Bushing (With shoulder) $\Phi 15 \times \Phi 17 \times 9$ -SF-1	2	
13	508098510035	Tiller components	1	
14		Screw GB70.1-M3x22-8.8	2	

**Fig. 13 Truck components**

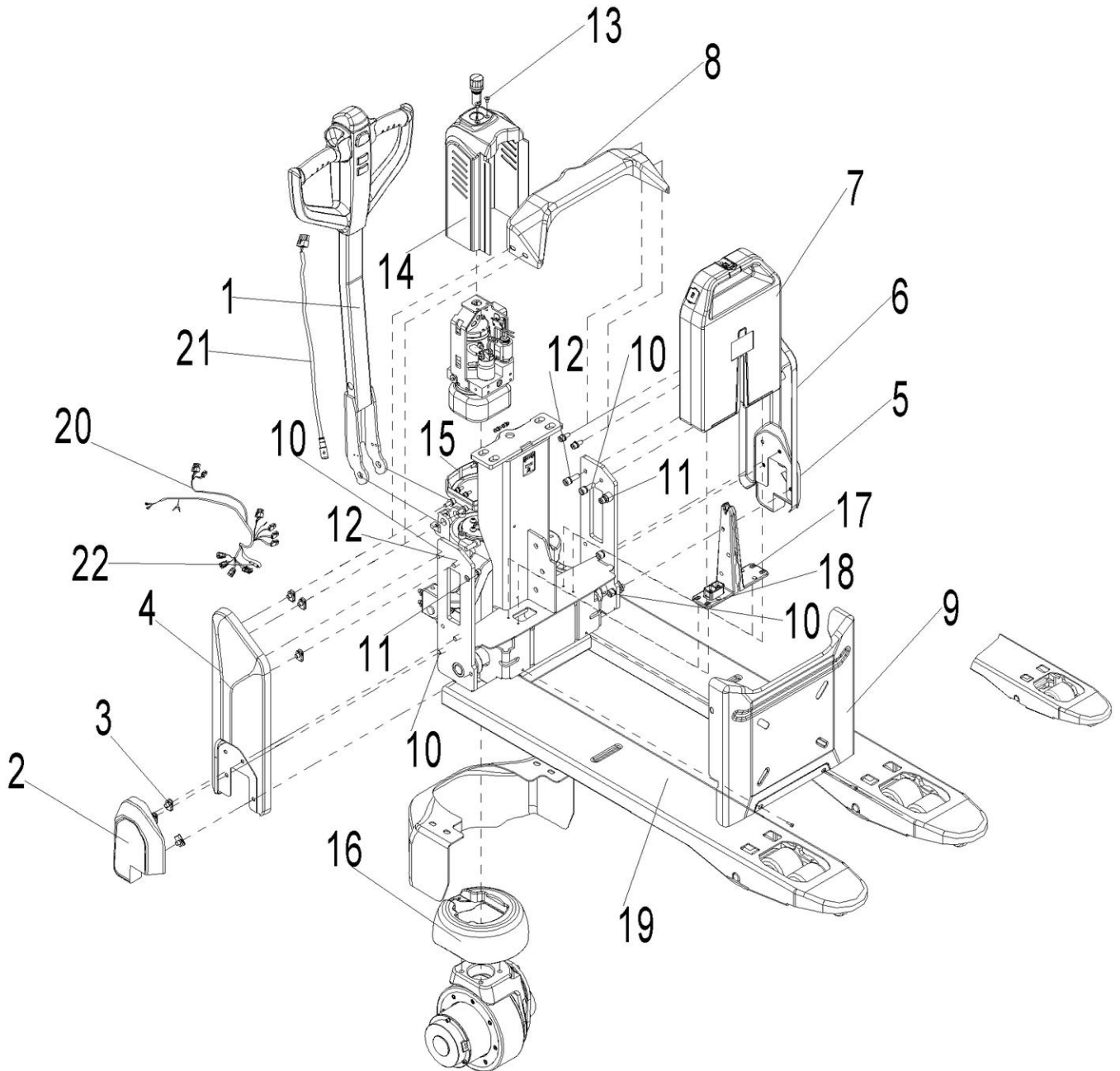
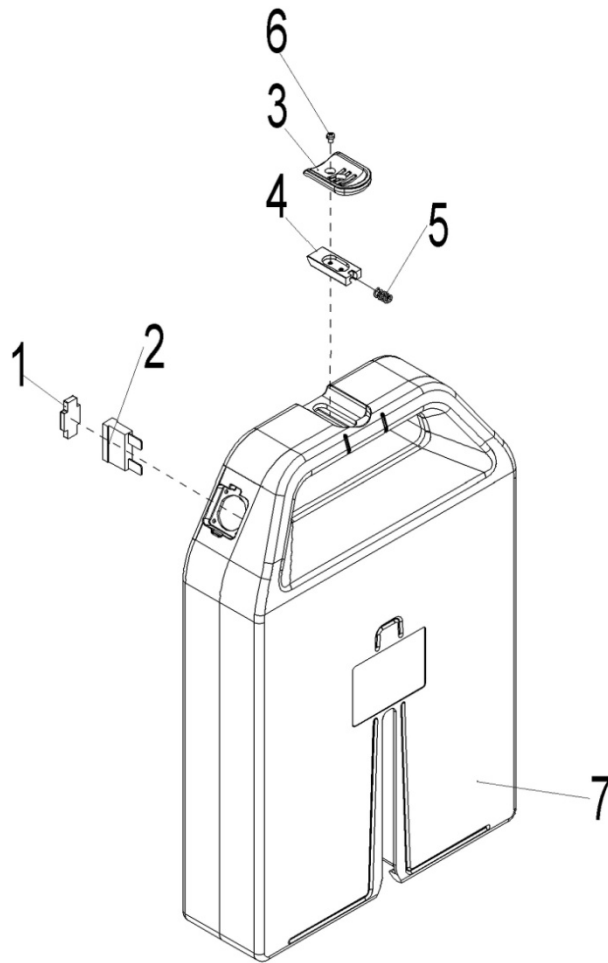

**Fig. 13 Truck Components**

No	Art No.	Description	Qty.	Note
1	508098510035	Tiller assembly	1	
2		Small side cover (right)(540)	1	
		Small side cover (right)(685)	1	

3		Nut M8-t(2-4)	14	
4		Side panel (right)	1	
5		Small side cover (left)(540)	1	
		Small side cover (left)(685)	1	
6		Side panel (left)	1	
7	508037010003	Lithium battery 24V20Ah	1	20Ah
8		Top cover	1	
9		Front cover	1	
10		Screw GB70.1-M8x25-8.8	10	
11		Screw GB70.1-M8x16-8.8	6	
12		Flat washer GB97.1-8-200HV	6	
13		Screw GB70.3-M6x10-8.8	2	
14		Pump protective cover	1	
15		Base cover	1	
16		Round cover	1	
17		Lithium battery guide base	1	
18		Screw GB818-M5x10-4.8	4	M5x10
19		Chassis welding (540x1150)		
20	508033010000	Main control wiring harness	1	
		Main control wiring harness	1	With speed reduction on curve
21	508033010001	Tiller control wiring harness	1	
22	920100200002	Fuse 10A	1	(982124)

**Fig. 14 Power supply assembly**



**Fig. 14 Power Supply Assembly**

No.	Art No.	Description	Qty.	Note
1	508098520021	Fuse protective cap	1	
2	920100200006	70A fuse	1	ATM70A DC32V
3	508098520022	Locker	1	
4	508098520023	Aluminium part	1	
5	508098520024	Spring	1	
6	910200500011	Screw	2	Screw GB818-M3x10-4.8
7	508037010003	Lithium battery 24V20Ah	1	20Ah

**Fig. 15 Controller components**

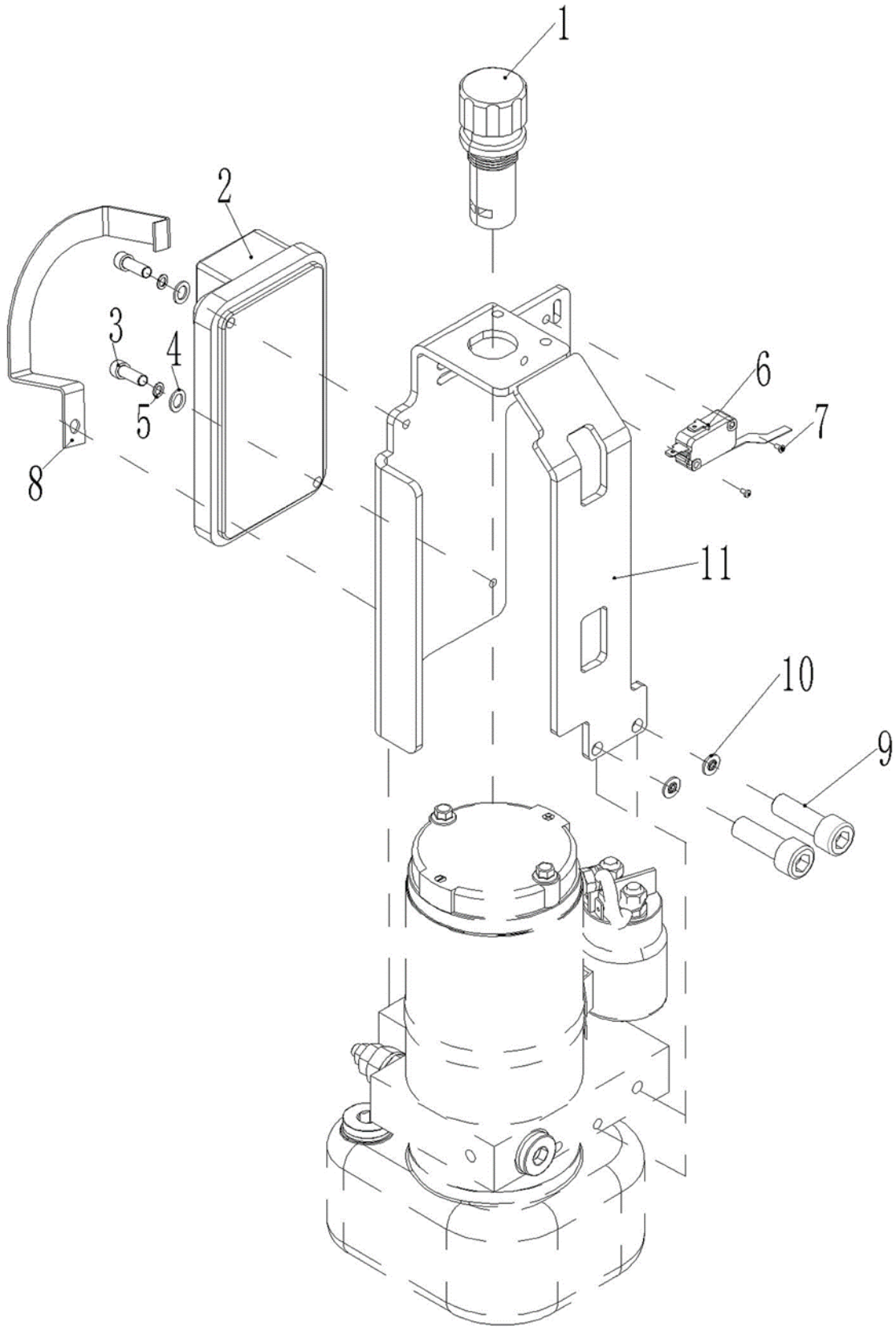
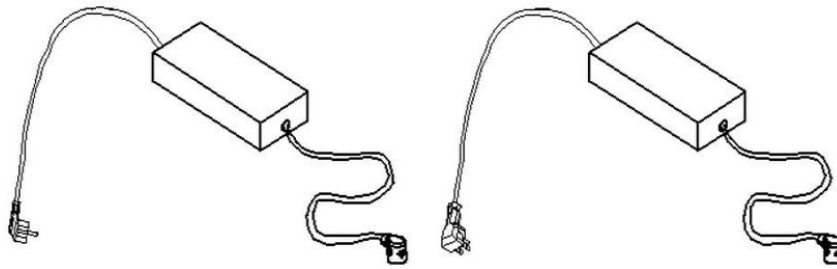

**Fig. 15 Controller Components**

No.	Art No.	Description	Qty.	Note
1	920200100015	Emergency button CE3T-10R-02	1	
2	921400100112	Controller 1212C-2504	1	
3		Screw GB70.1-M5x25- 8.8	2	Screw GB70.1-M5x25- 8.8-c1B
4		Flat washer GB97.1-5- 200HV	2	Flat Washer GB97.1-5- 200HV-A-c1B
5		Washer GB93-5	2	Washer GB93-5-c1B
6	920200300012	Micro switch V-J163- 1C25	1	
7		Screw GB70.1-M3x12- 8.8	2	Screw GB70.1-M3x12- 8.8-c1B
8		Cable clamp	1	
9		Screw GB70.1-M6x20- 8.8	7	Screw GB70.1-M6x20- 8.8-c1B
10		Flat Washer GB97.1-6- 200HV	7	Flat Washer GB97.1-6- 200HV-A-c1B
11		Controller mounting rack	1	



**Fig. 17 Charger**



EU market

US market

**Fig. 17 Charger**

No.	Art No.	Description	Qty.	Note
1	508036510003	Lithium battery charger 24V- 110V	1	US
	508036510004	Lithium battery charger 24V- 230V	1	EU

**Fig. 18 Wiring harness**

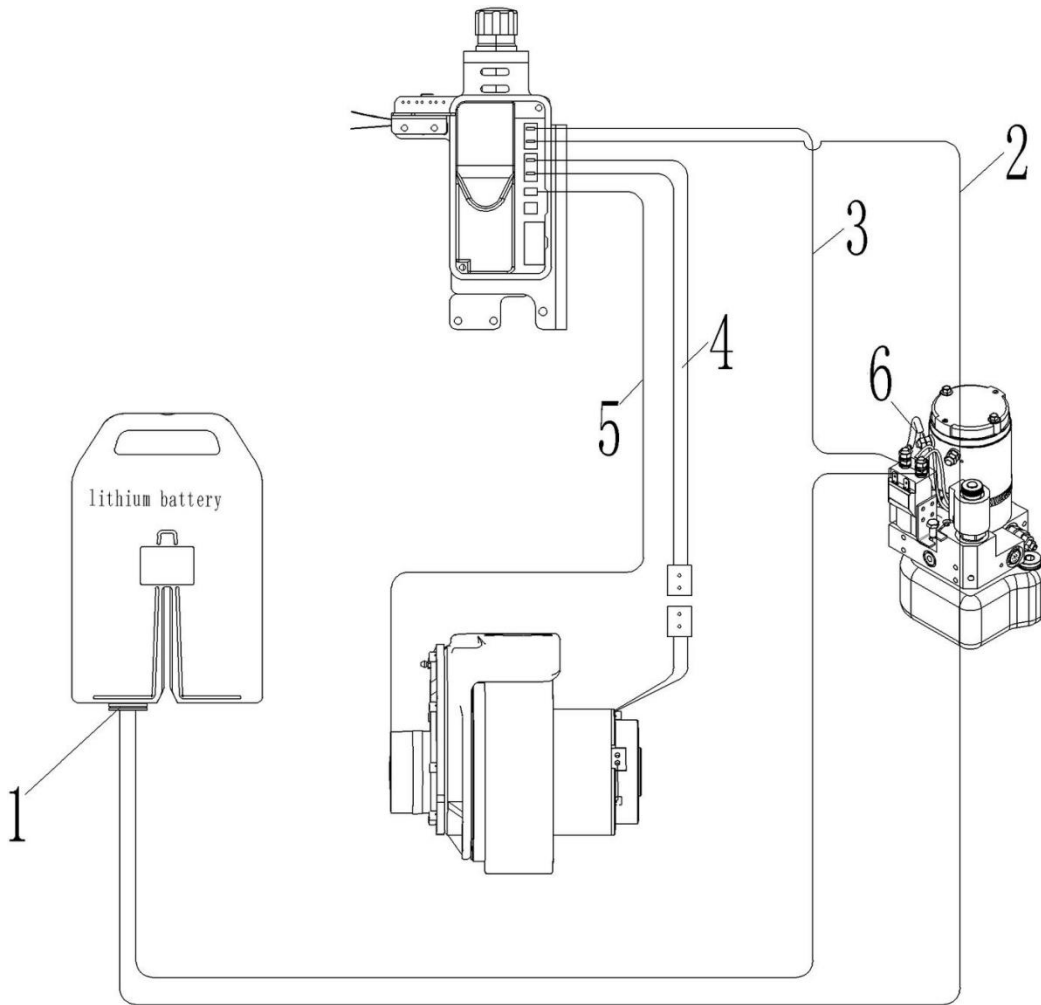

**Fig. 18 Wiring Harness**

No.	Art No.	Description	Qty.	Note
1	508033010003	Main plug wiring harness	1	
2	508033010004	Controller B+ wiring harness	1	
3	508033010005	Controller B- wiring harness	1	
4	508033010006	Motor main wiring harness	1	
5	508033010007	Brake main wiring harness	1	
6	508033010010	Pump motor B+ wiring harness	1	



**S1096 Spare parts list LM1500**