

LOGIFLEX ELFR / ELFSR - ROTATOR

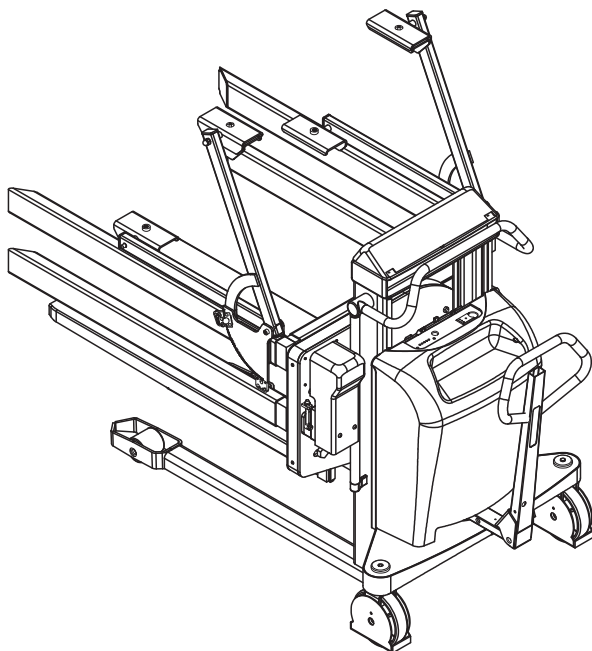

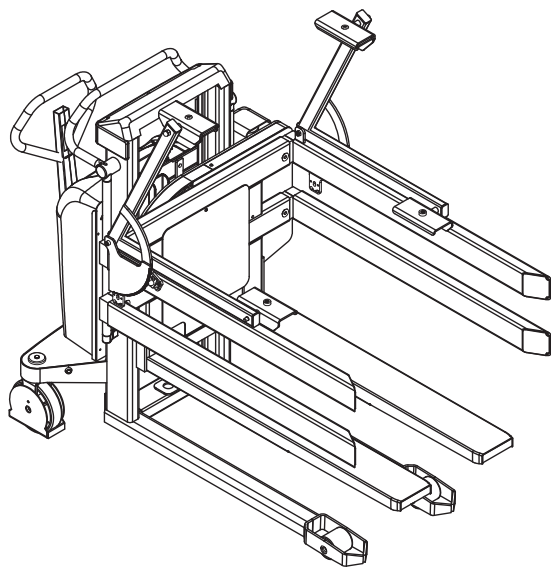

Contents

1.0 Before the first lift...	4
2.0 Functions and identifications	5
3.0 How to operate the Logflex with Rotator	7
3.1 Handling of pallets	7
3.2 Use of the Rotator	8
3.3 Adjusting of stop	9
3.4 Setting the speed	9
3.5 Reset	9
4.0 Optimum safety	10
4.1 Avoid overloads	10
4.2 Avoid offset loads	11
4.3 Rotation range	12
4.4 Safety regulations	14
4.5 Driving loaded	15
4.6 Rotation with load	15
4.7 Emergency braking and Emergency stop	16
5.0 There must be a current supply...	17
5.1 Fuses - replacement	17
5.2 Wiring connections	17
6.0 Long live Logiflex with Rotator	18
6.1 Lubrication and hydraulic oil	18
6.2 Oil change	18
6.3 Fork adjustment	19
6.4 Adjustment of lifting chain	19
6.5 Adjustment of steering wheel chains	20
6.6 The hydraulic pump and gear motor	20
6.7 Cleaning	20
6.8 Adjustment of side play	21
7.0 Adjusting the Rotator	22
7.1 Tensioning the chains	22
7.2 Adjusting the switch	23
7.3 Lubrication	23
8.0 Fault location key	24
9.0 Good service after purchase	26
9.1 Ordering spare parts	26
9.2 Warranty/Compensation	26
9.3 Service and repair	26
9.4 Warranty	26
9.5 Liability exemption	26



1.0 Before the first lift...

The Logiflex with Rotator is manufactured in accordance with safety directives.

Among the subjects dealt with in this **Instruction Manual** are:

- *Proper application*
- *Physical limitations of the product*
- *Risks with improper use*

- Therefore please read this Instruction Manual carefully!

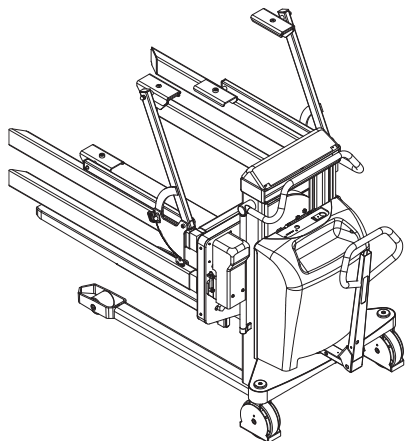
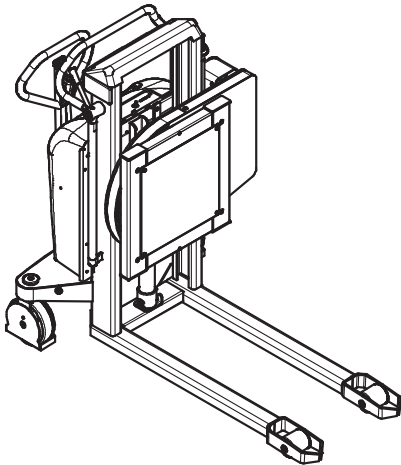

2.0 Functions and identifications

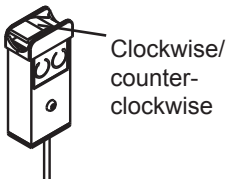
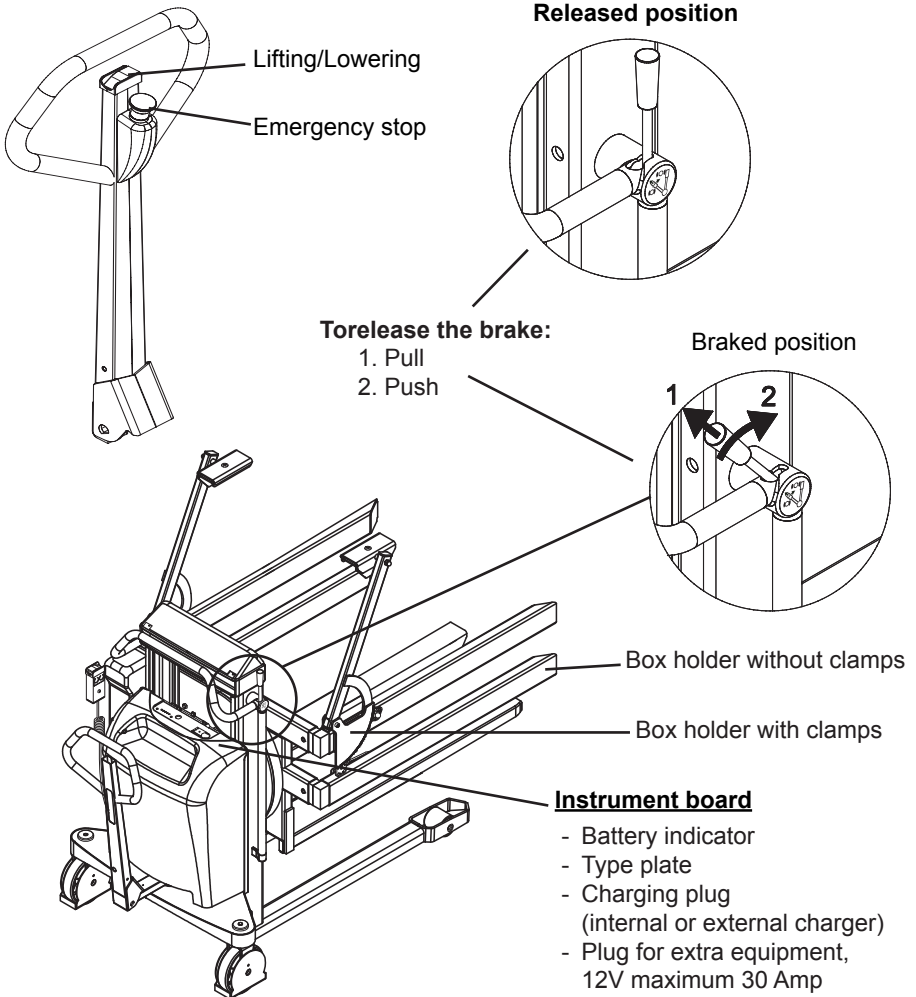

Remote control

The remote control is used when:

- Rotating the forks
- Setting tilt stop in both directions: See paragraph 3.3.
- Setting rotation speed: See paragraph 3.4.

2.0 Functions and indentifications

Box holder

The rotator can be equipped with one or two sets of box holders, adjusted for different box sizes. When loosening the screw (A), the box holder can be moved between the two different positions.



NOTE! The screw has to be tightened, before using the product.

Setting of distance between box holders

- Fork span 560 mm: Fits the box widths 800 or 1000 mm.
- Fork span 680 mm: Fits box widths 1000 or 1200 mm.

Setting of height

The box holders can be placed in two different heights

- It is important that the box holders are placed approx. on the level of or above the load centre of the load.
- If possible, use two box holders in each side
 - 1) When the weight of the load is between 800 and 1000 kg.
 - 2) For high boxes or when the material of the box is unstable, e.g. cardboard

NOTE! If the box holders have no clamps, the load is not allowed to be tilted more than 60° to each side.

Box holders with clamps

If the box can fall off, or if it has to be tilted more than 60°, box holders with clamps have to be used.

Box holders with clamps can grip, hold and rotate boxes with different heights.

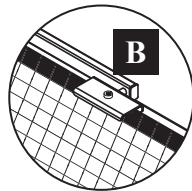

The clamps are placed on the frame of the box and tightened when the box is lifted up (no contact to the floor).

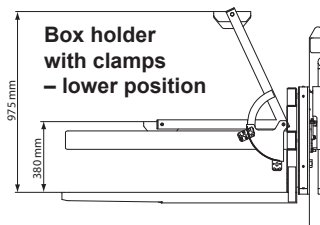
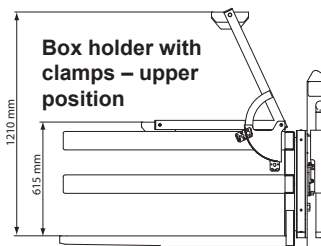



3.0 How to operate Logiflex w/Rotator

3.1 Pallet handling

The Logiflex with Rotator functions as an ordinary stacker, when the forks are placed in horizontal position.

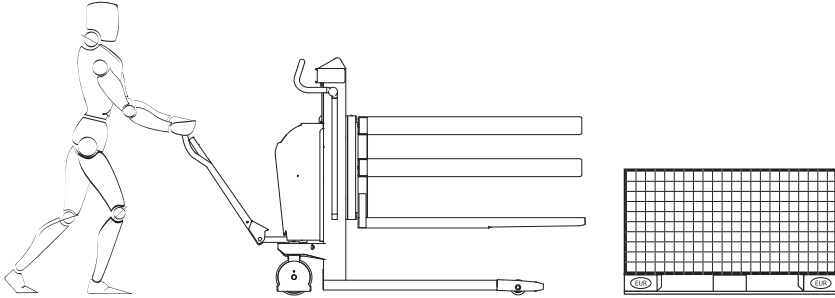

For proper operation,
stand behind the handle.

Push/pull - raise/lower

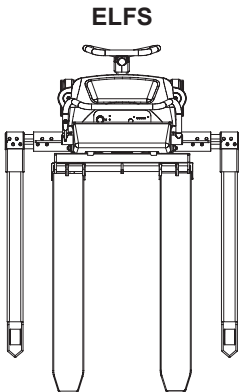
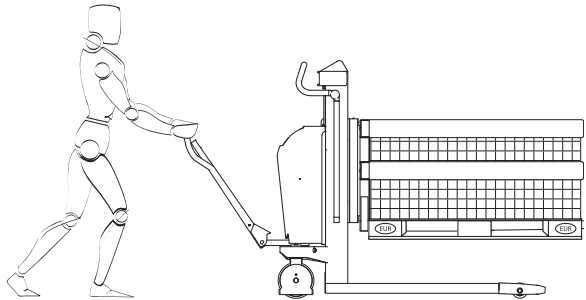

When handling closed pallets
- use the straddle Logiflex!

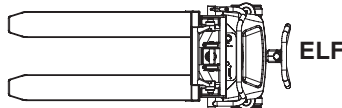
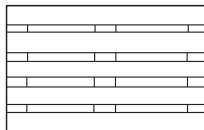

3.0 How to operate the Logiflex with Rotator

3.2 Use of the Rotator

Condition: The upper edge of the forks is lifted between 400 and 900 mm.

The load can be rotated 355° with one adjustable stop in every side.

Note! To continue the tilt function from the horizontal position, the tilt switch has to be released and activated in the requested tilt direction.

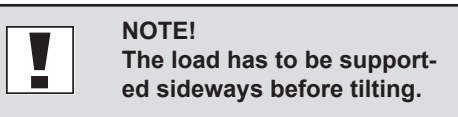

To lower the or to lift higher than 900 mm, the forks have to be placed in horizontal position.

Soft acceleration / deceleration

The Rotator has soft acceleration / deceleration with the following benefits:

- The rotation stops precisely
- The gear is protected, because sudden start / stop are minimised.

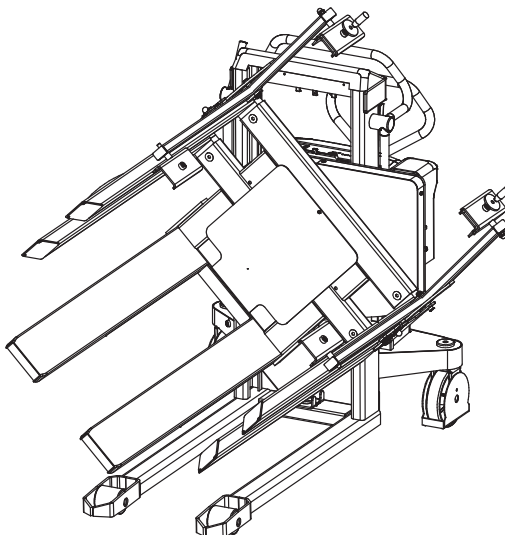

3.0 How to operate the Logiflex with Rotator

3.3 Adjusting of stop

The forks are factory-set to stop in 45°. If another setting is required, the Rotator can be set electronically to stop in different angles.

- 1) The forks are placed in horizontal position.
- 2) Short pressure on the switch A activates the setting procedure. The controller gives a signal (one beep).
- 3) The forks are placed in the requested angle.
- 4) When the forks have reached the requested angle, the controller will give signal after three seconds (one beep), when the position has been stored.

The procedure is repeated to set stop no. 2.

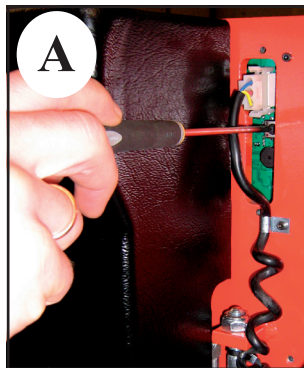

3.4 Setting the speed

- 1) The forks are placed in horizontal position.
- 2) The switch is pressed three seconds, and two short beeps will be given. The switch is released and the speed is set by activating the remote control.

Clockwise: Increasing the speed

Counter-clockwise: Reducing the speed

Note: Maximum tilt time (0-355°): 1 minute.

- 3) When the requested speed has been reached, the controller will give signal after three seconds (two beeps), when the position has been stored.

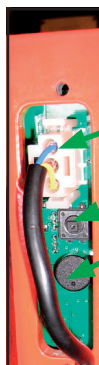

Plug from remote control

Switch A

Signal

3.5 Reset the settings

- 1) The forks are placed in horizontal position.
- 2) Press switch A, until five beeps are given. The switch is released and the controller is set to maximum speed and stops at 45°.



4.0 Optimum safety

4.1 Avoid overloads

The maximum load must not be exceeded. **Remember**, that the Logiflex with Rotator is designed for evenly distributed load, - goods on pallets etc. If the forks are point-loaded on one side, there is a risk of bending.

NOTE! When driving with the truck, the forks should be placed in horizontal position.

Max. capacity of the Rotator/Multi-purpose carriage: 1000 kg / 700 Nm (see load diagram).

Load diagram

When the forks are tilted, the spatial position of the load changes. This means that the load capacity that can be tilted is reduced, the larger the distance is between load centre of the load and rotation centre.

In order to use the load diagram, the following three facts have to be known:

- The distance from the upper edge of the forks/below edge of the Multi-purpose carriage to the load centre
- Requested tilt degree
- Weight of the load

Example:

- The load centre is placed 120 mm (A) over the forks/ below edge Multi-purpose carriage
- Tilt degree: 90° (B)
- Weight of the load: 400 kg

It appears from the load diagram that the maximum allowed load is 425 kg (C).

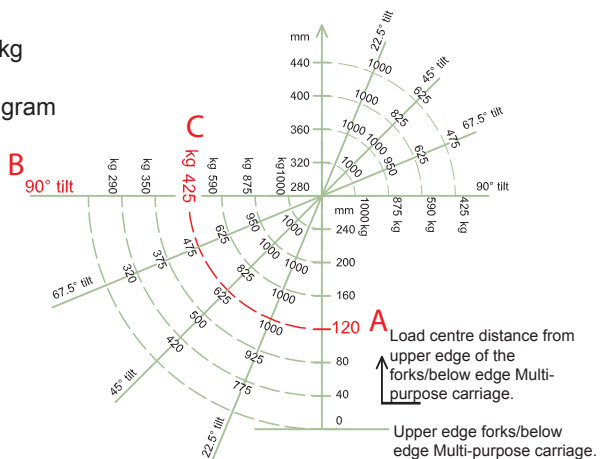

NOTE! If the load centre exceeds the allowed distance shown in the load diagram, there is a risk that the stacker will turn over, when rotating.

4.0 Optimum safety

4.2 Avoid offset loads

The load must be evenly distributed. The maximum centre of gravity distance from the front of the fork mast (given on the truck) must not be exceeded. A greater distance reduces the level of safety and increases the risk of toppling.

Goods on pallets, etc. must be properly secured, so that they cannot fall off during transport, when the truck is lifted, or when the truck must remain lifted for a time.

Marking

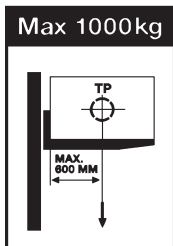

The mast lifting capacity and the corresponding centre of gravity distance are given by the pictogram on the side of the mast.

The lifting capacity of the mast is the same as the max. lifting capacity of the product.

Max. lifting capacity is set on the safety valve of the product.

4.0 Optimum safety

4.3 Rotation range

Standard version

The load can be rotated, when the upper edge of the forks are lifted between 400 and 900 mm. Outside this range, the stacker functions as a standard stacker.



Top stop

Indicates that the forks are lifted 900 mm above the floor.

NOTE: Top stop is only placed on stackers with lifting heights, being higher than:

ELF / SELF 1001/920

ELFS / SELFS 1001/890

Bottom stop

Indicates that the forks are lifted 400 mm above the floor.

4.0 Optimum safety

Special version

The top stop can be set to other intervals than between 400-900 mm.

The height of the top stop depends on the width of the stacker, as a wide stacker can manage a larger sideways movement.

E.g.

On a stacker with 850 mm straddle legs, the stop can be placed at a maximum fork height of 1880 mm.

Normal range for the maximum load 1000 kg /700Nm, fork height 400-900 mm.

Range of maximum load 1000 kg /700Nm of stacker in special version

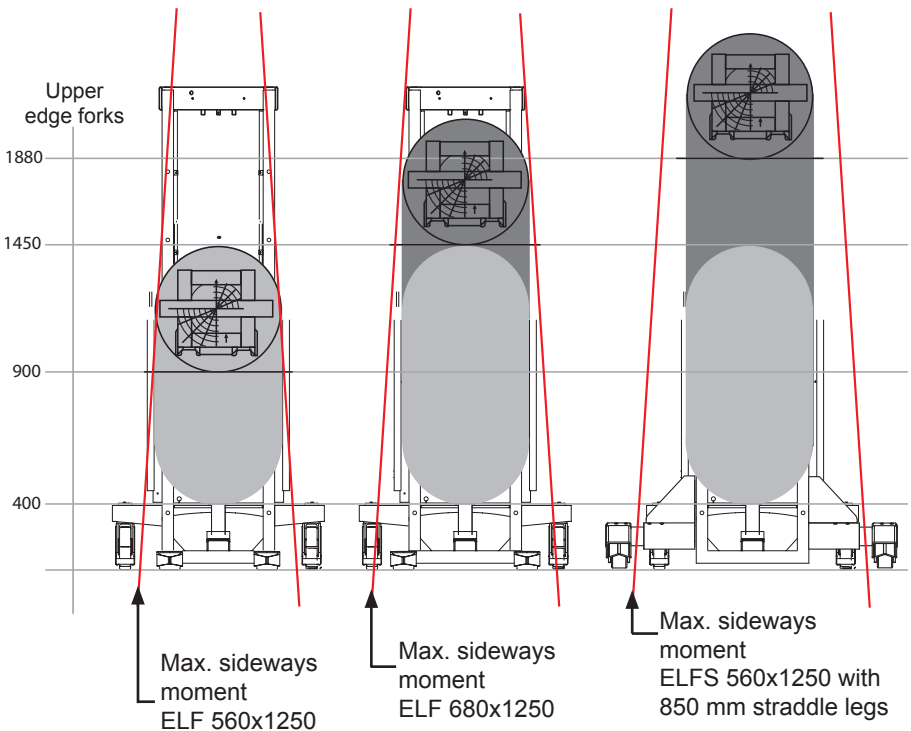

4.0 Optimum safety

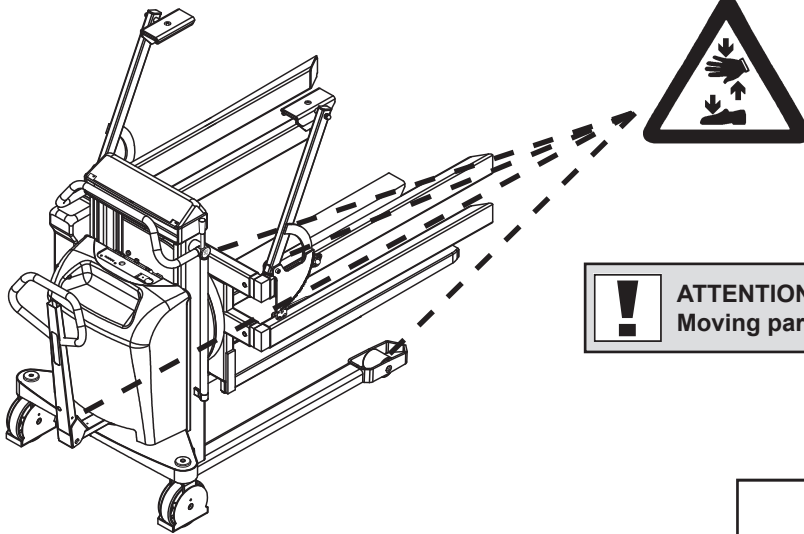

4.4 Safety regulations

- Never walk under a raised load!
- Before lowering the forks, make certain that no foreign elements can hinder the free lowering of the forks
- The LOGIFLEX is designed for use on an even and level floor
- During transport the forks shall be raised as little as possible
- Transport with raised forks should be made over the shortest possible distances and at low speed
- Check that the chains lift equally. They shall be equally tight when the forks are loaded
- Chains and chain bolts must not be damaged. Chains that have become permanently stretched (max. 2 % of original length) must be scrapped.



4.0 Optimum safety

4.5 Driving loaded

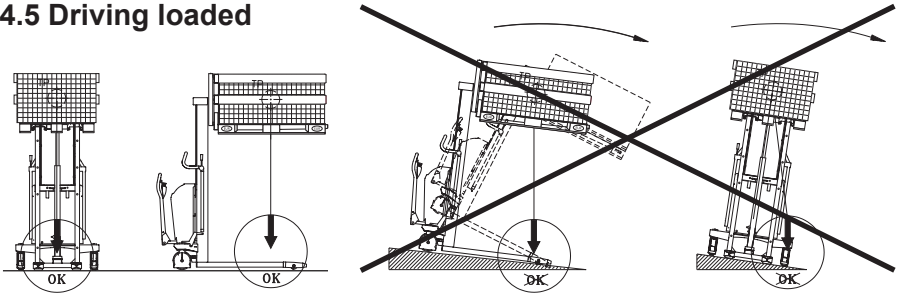

The Logiflex is designed for use on even and level floor. During transport the forks shall be raised as little as possible. Transport with raised forks should be made over the shortest possible distances and at low speed.

4.6 Rotation with load

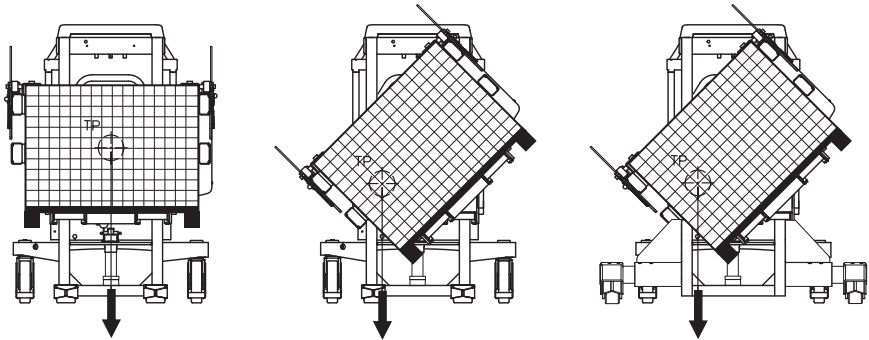

The load centre is not allowed to be placed on the outside of the legs of the stacker, as this will cause a risk of turning over.

NOTE! Rotation is only allowed to take place, if the stacker is placed on an equal floor.

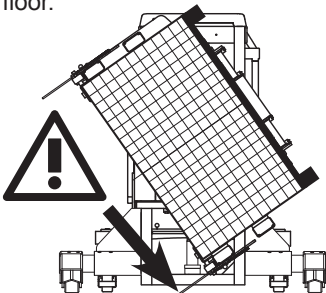

When rotating boxes, the operator needs a full overview of the whole working area, so that the rotation movement can be stopped before the box touches the floor, the items or persons in the working area.

4.0 Optimum safety

4.7 Emergency braking and Emergency stop

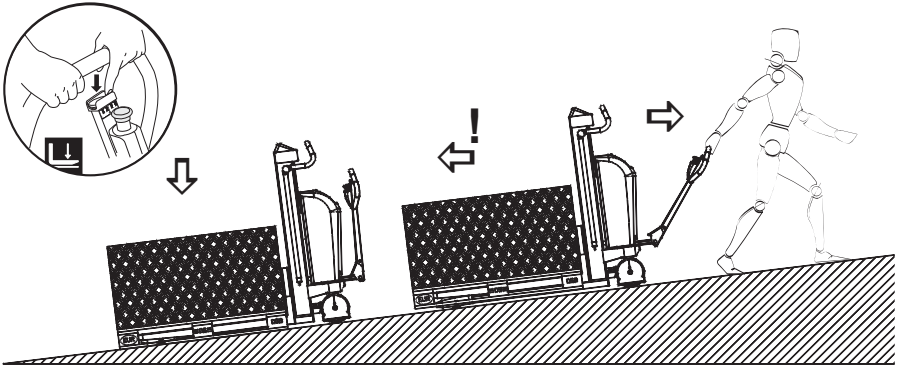

If it becomes necessary to use the load as a brake to prevent the LOGIFLEX from running away, activate the DOWN button quickly, until the load reaches the ground.

The product has an emergency stop. When activating the emergency stop, the main current supply is switched off. The movement of the forks stops immediately when activating the emergency stop.

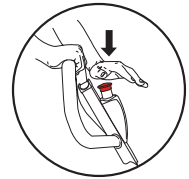

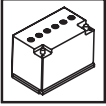

5.0 There must be a current supply...

5.1 Fuses - replacement

There are five fuses in the electrical circuit.

80 Amp fuse in the main supply from battery

5 Amp fuse in the control current circuit

15 Amp fuse (plug for extra equipment on the instrument board)

10 Amp fuse for built-in charger

40 Amp fuse for Rotator

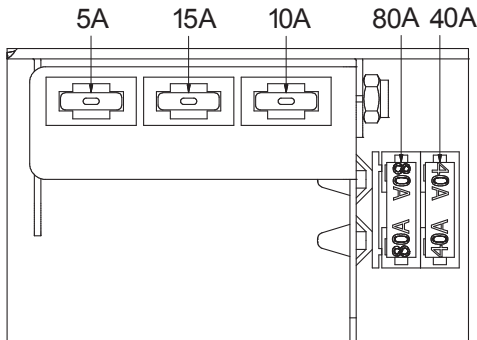

Replacement:

The old fuse is to be removed and replaced by a new one of the same size.

Find out why the fuses blow!

5.2 Wiring connections

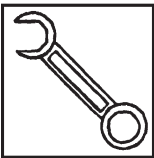

Many operational disturbances are caused by bad connections in the electrical circuit. Make sure that the connections are in order.

Check connections regularly for damage at insulating caps or bad connections at plugs etc. Verdigris must be removed from cable plugs. Keep all screw/nut connections tight.



6.0 Long live Logiflex with Rotator

Regular inspection and the replacement of worn or defective parts in good time will prolong the life of the Logiflex. "Prevention is better than repair", therefore ensure:

- Check battery every 14 cycles
- Correct usage
- Regular cleaning
- Periodic safety and service inspection
- For safety reasons please check the below every 3 month:
 - Tighten loose screw and nuts
 - Check that there are no cracks, fractures and deformations in the bearing construction
 - Wearing parts, such as brakes, wheels and bearings, are adjusted and exchanged continuously

6.1 Lubrication and hydraulic oil



Under normal operation conditions the Logiflex requires no lubrication. All ball bearings are sealed and lubricated for life, and moving parts have self-lubricating bearings or are treated with grease.

The hydraulic system is filled with hydraulic oil of viscosity class ISO VG 15. An additive is added to the oil: - Wynn's Hydraulic Systems

Concentrate. The concentrate reduces friction and wear and protects against corrosion. Pre-mixed hydraulic oil with additive is available from the dealer. The oil is suitable for use in the temperature range -10 to +50° C. A thinner oil is recommended for temperatures lower than -10° C (if necessary, contact your dealer).

6.2 Oil change

Draining the oil:

1. Bring the unloaded forks down to the lowest position.
2. Most of the oil can be drained by loosening the hydraulic hose union and briefly activating the hydraulic pump with the switch.
3. The remaining oil can be drained from the oil tank by taking off the twelve clips on the pump and removing the tank.

Oil filling:

4. Fill oil through the filling hole on the tank.
5. Oil quantity:

ELF 920 & ELFS 890	approx 1,5 liter
ELF 1200 & ELFS 1170	approx 3 liter
ELF 1400 & ELFS 1370	approx 3 liter
ELF 1600 & ELFS 1570	approx 3 liter
ELF 1910 & ELFS 1880	approx 4 liter
6. Refit the filling cap and bleed the system (6.6).

6.0 Longe live Logiflex with Rotator

6.3 Fork adjustment

Two of the rollers on the fork bracket are mounted on eccentric pins, so that they can be adjusted. The adjustable rollers are at the top.

1. Loosen screw (pos. 91) (key width 5 mm).
2. Eccentric pins (pos. 56) (key width 8 mm) can now be turned to give the necessary fork adjustment.
3. Adjustment must be made on both sides to ensure uniform loading of the rollers.

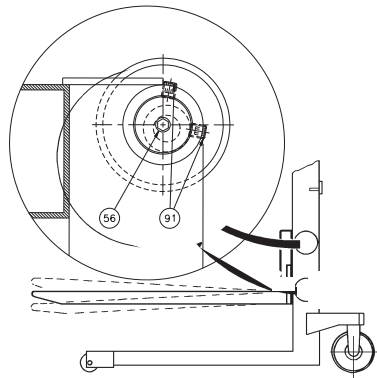

6.4 Adjustment of lifting chain

The chains shall be adjusted so that

- they lift equally
- they are equally tight
- The lifting movement has to stop in the cylinder, before the mast rolls touch the top stop.

After adjusting, please check:

- a: Fork bracket: the forks have to be placed above the wheels
- b: Adjustable carriage: the forks are to be kept clear of the floor

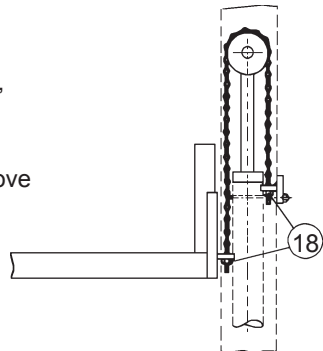

The nuts (pos. 18) are to be adjusted (nut M12, key width 19 mm).

6.0 Longe live Logiflex with Rotator

6.5 Adjustment of steering wheel chains

- Set the handle in its middle position.
- Adjust the nuts (1, 2, 3 and 4) and bring the wheels into parallel.

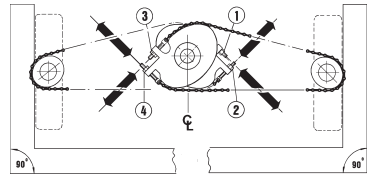

6.6 The hydraulic pump and the gear motor

The hydraulic pump has a S3 "periodic intermittent duty" of 10%. This means that the pump in total is allowed to operate 1 minute for a period of 10 minutes. If the pump operates more than 10%, the motor will be damaged due to superheating.

Bleeding the hydraulic system

With a load of 50-100 kg, the forks must be raised and lowered to top and bottom position 2-3 times.

Gear motor of Rotator

The gear motor has a "short time under constant load" of 10 minutes (S2=10 minutes). This means that the motor is allowed to operate with the maximum load for 10 minutes. Hereafter it has to be cooled down to normal temperature.

NOTE! The motor will be damaged by superheating, if it operates for a longer time or if it is not cooled down.



6.7 Cleaning

When cleaning the Logiflex, do not direct the jet onto bearings and seals. Otherwise the grease will be washed out and the life of the equipment shortened.

Cleaning of the plastic screen (polycarbonate)

The screen is to be washed with slightly warm water added a neutral cleaning material, and afterwards washed with clean water.

Use a soft sponge, a woollen cloth or a wash leather.



Never use sharp objects or solvent cleaners when cleaning.

6.0 Longe live Logiflex with Rotator



6.8 Adjustment of side play

(In the mast rolls of the right side of the fork bracket)

1. Screw (A) is loosened counter-clockwise, until resistance disappears.
2. Turn the screw clockwise, until resistance appears. The follo wing 1.5 to 2.5 turns of the screw will be a tightening of the spring (C).
3. When a larger resistance appears, make 0.25 turn counter-clockwise, and the counter nut (B) will be tightened.
4. Pump the forks to its top position, and when lowering it has to slide to the bottom. If this is not the case, loosen screw A, make c. 0.5 turn counter-clockwise and repeat point 4.

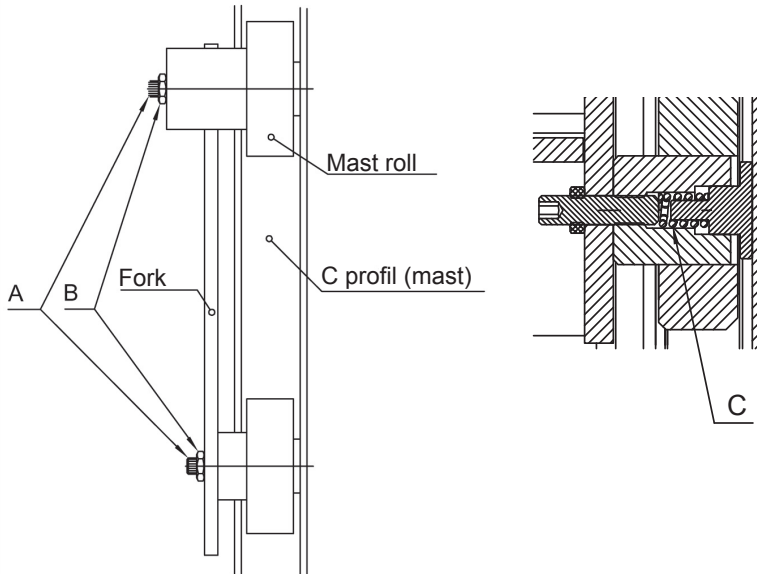

7.0 Adjusting the Rotator

7.1 Tensioning the chains

When the unloaded forks can be tilted manually approx. 5 cm, the chains should be tensioned.

This is done by:

- 1) Removing the cover from the tilt unit.
- 2) Loosening the gear motor (A1)
- 3) Loosening chain wheel (B1)
- 4) Turning the nut (B2), so that the fork chain is tensioned, until the slack is about 5 mm.
- 5) Tightening the chain wheel (B1)
- 6) Tightening the nuts for the gear motor (A2), so that the chain is tensioned, until the slack is about 2-3 mm. Tighten the nuts (A1) again.
- 7) Replace the cover.

NOTE!

Check the location of the inductive switch (see 7.2) and check that the fork chain is tightened correctly in the whole rotation area after adjusting the chains.

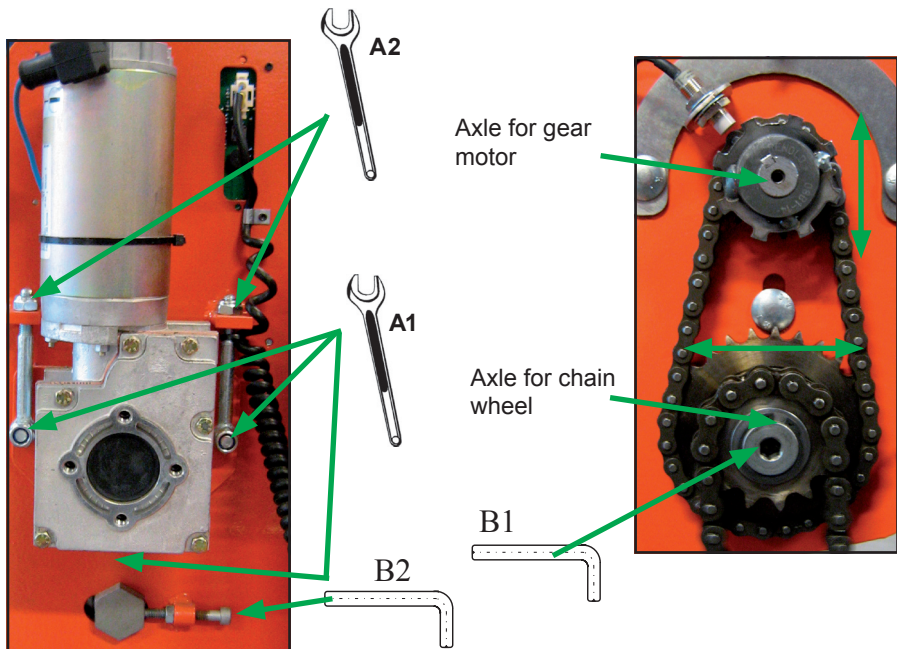

7.0 Justering af Rotator

7.2 Adjusting the switch

The location of the forks is decided by two inductive switches.

A) Inductive switch on thrust ring

Indicates when the forks are in horizontal position.

When the forks are in horizontal position, the inductive switch has to be placed right above the plate on the thrust ring in a distance of 2-4 mm.

B) Inductive switch on the teeth of the little toothed wheel

The number of the impulses indicates the angle of the forks.

The distance from the inductive switch to the tooth has to be 2-4 mm.

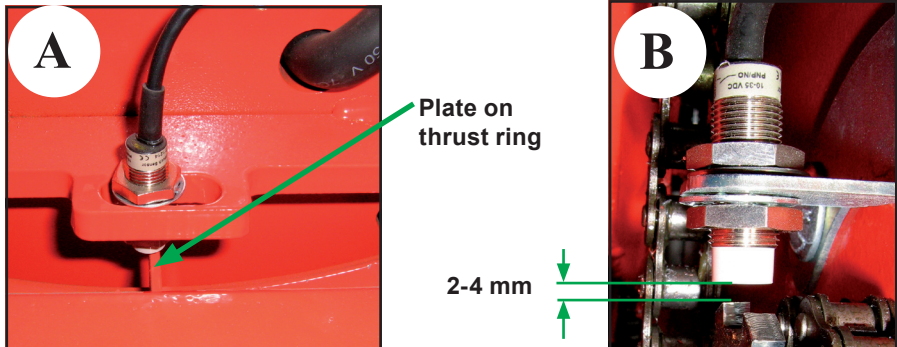

7.3 Lubrication

Support block

To support the thrust ring, two support blocks are placed behind the ring.

The blocks have to press on the ring, and the back of the ring has to be lubricated with grease, so that the blocks slide smoothly.

Chains

The chains of the Rotator have to be lubricated with grease twice a year.

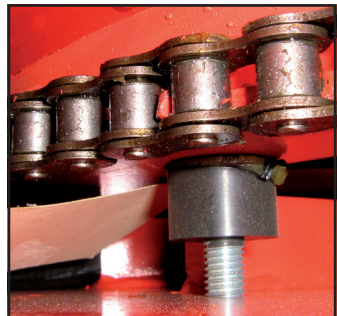



8.0 Fault location key

When the LOGIFLEX is used every day, adjustments and the replacement of worn parts might be necessary..

Adjustments and minor repair can easily be made on the spot. Major repairs should, however, be carried through by the dealer whos has a well-trained staff and the necessary special tools.



**Before asking the dealer for assistance...
...try the fault location key!**

SYMPTOMs AND OBSERVATIONS

- A** Pump does not run when the UP button is pressed _____
- B** Truck does not lift when the UP button is pressed _____
- C** Truck does not lift to max. height _____
- D** Forks fall after being raised _____
- E** Forks do not not fall when DOWN button is pressed _____
- F** Forks cannot be lowered fully _____
- G** Trucks is unable to lift the max. load _____
- H** Truck lifts slowly _____
- I** Forks do not lift horizontally _____
- J** Steering wheel does not drive evenly _____

Cause

Mending

	Oil deficiency	See point 6.1/6.2
	Battery discharged	See separate instruction
	Fuse blown 5Amp or 80Amp	See point 5.1
	Cables defective	See point 5.2
	Max. load exceeded	See point 4.1
	Air in hydraulic system	See point 6.6
	Pressure relief valve incorrectly adjusted	Contact the dealer
	Leakage in hydraulic system Visible oil leakage	Contact the dealer
	Fork bracket needs adjustment	See point 6.3/6.4/6.8
	Solenoid or check valve defective	Contact the dealer
	Defective valves in pump	Contact the dealer
	Steering wheel out of adjustment	See point 6.5
	Defective solenoid valve	Contact the dealer
A		
B		
C		
D		
E		
F		
G		
H		
I		
J		

A
B
C
D
E
F
G
H
I
J

If the problem cannot be solved by using the fault location key...

...please contact your dealer!





9.0 Good service after purchase

9.1 Ordering spare parts

The correct spare parts are obtainable from your dealer.

When ordering, please state:

- Serial number of the product
- Type and width/length of the product
- Spare part no. Please find spare part no. on **www.logitrans.com**

9.2 Warranty/Compensation

Spare parts delivered during the warranty period will be invoiced. A credit note will be sent immediately after we have received and tested the defective parts and found that the warranty conditions have been met.

9.3 Service and repair

You should be able to make adjustments and perform minor repairs on the spot. However, major repairs should be left to the dealer who has well-trained personnel and the necessary special tools. The manufacturer has an exchange system for pumps/cylinders. These are renovated and delivered with warranty.

9.4 Warranty

The warranty covers material and assembly defects which, subject to inspection by us or our representative, are deemed to be faults or deficiencies that prevent normal use of the parts concerned. Such affected parts shall be sent to your Logitrans dealer carriage paid within the warranty period in force at the time in question, together with a copy of the documentation for the service performed (B284 - see the back page). The warranty does not cover normal wear and adjustments. The warranty period is based on singleshift working.

The warranty shall no longer apply if

- the product has been used incorrectly,
- the product is used in environments for which it was not designed,
- the product has been overloaded,
- replacements of parts have been made incorrectly or original parts have not been used and consequential damages have arisen,
- if the product is changed or accessories, not being approved by Logitrans, are used.
- it can not be proved that a qualified technician has performed the service check according to the requirements stated in the instruction manual (see the back page).

9.5 Liability exemption

The manufacturer accepts no responsibility for personal injury or material damage arising from deficiencies, defects or improper usage. The manufacturer accepts no responsibility for lost earnings, operating losses, lost time, lost profits or similar indirect losses incurred by the purchaser or a third party.

Periodic service check

Service check is required once each year.

The service check is to be performed on the basis of form no. B280 and proved on form no. B284. Forms and instructions for the service check are available at your dealer.

Periodic safety inspection

Safety inspection should be performed by the dealer or other qualified persons at least once each year, unless local regulations state otherwise.

The safety inspection to be performed on the basis of form no. B278 and proved on form no. B284. Forms and instructions for the safety inspection are available at your dealer.

S 847

ELRF-L-EN

01122008/02