

REEL ROTATOR ELFRRE / ELFSRRE, ELFRRM / ELFSRRM

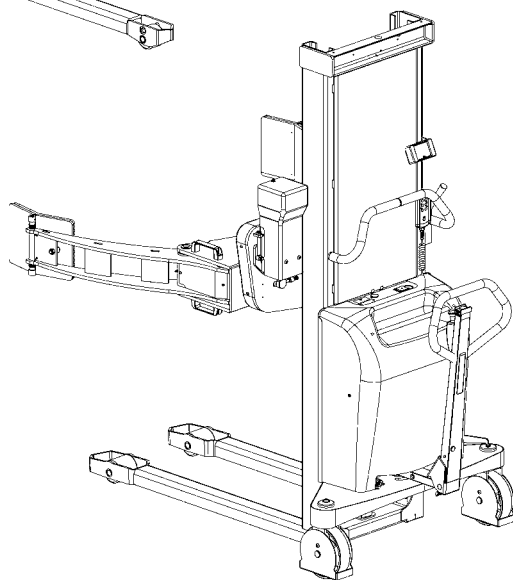
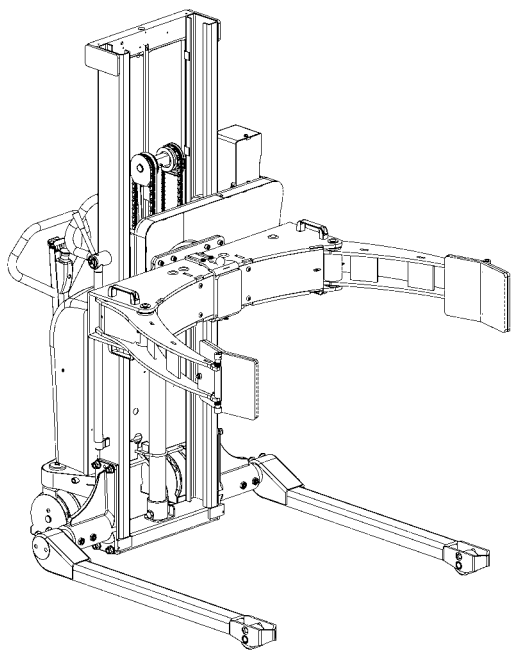

EU DECLARATION CONFORMANCE

Manufacturer: **Logitrans A/S**
Address: **Hillerupvej 35**
6760 Ribe
Danmark

hereby declares that:

machine: Product group: **Reel Rotator**

Type: ELFRRE1001/ELFSRRE1001
 ELFRRM1001/ELFSRRM1001

Production year/
Serial no:

a) has been manufactured in conformance with the stipulations of the:

- **Directive no. 2006/42/EC**
- **Directive no. 2014/30/EC**
- **Directive no. 2014/35/EC**

b) has been manufactured in conformance with the stipulations of the standard:

- **EN ISO 3691-5**

Responsible for the technical dossier:

Name: **Gitte Kirkegaard**
Address: **Hillerupvej 35, DK-6760 Ribe**

Signature:



Gitte Kirkegaard, CEO, Logitrans A/S

Ribe, 20.03.2020.



Contents

1.0 Before the first lift...	4
2.0 Functions and identifications	5
3.0 How to operate Reel Rotator	6
3.1 Handling of reels	6
3.2 Use of the Reel Rotator	6
3.2.1 ELFRRE, ELFSRRE	6
3.2.2 ELFRRM, ELFSRRM - Manual rotation	7
3.3 Remote control MR-1 / Lifting-Lowering-Rotation-Clamping (ELFRRE,ELFSRRE)	8
3.4 Remote control MR-1 / Lifting-Lowering-Clamping(ELFRRM,ELFSRRM)	8
3.5 Remote control / Lift and lower / Rotation	9
3.6 Clamping of reels	10
3.7 User-Interface LUI-1 Reel Rotator	12
3.8 Setting up User-Interface LUI-1 Reel Rotator	12
3.8.1 Home display	12
3.8.2 Display for Setup	13
3.8.3 Setting of rotation speed	13
3.8.4 Setting of stop position	14
3.8.5 Deleting stop positions	14
4.0 Optimum safety	15
4.1 Safety regulations	15
4.2 Rotation range	16
4.3 Driving loaded	16
4.4 Rotation with load	17
4.5 Emergency stop	17
5.0 There must be a current supply...	18
5.1 Fuses - replacement	18
5.2 Wiring connections	18
6.0 Long live Reel Rotator	19
6.1 Lubrication and hydraulic oil	19
6.2 Oil change	19
6.3 The hydraulic pump and the gear motor	20
6.4 Reel carriage adjustment	20
6.5 Adjustment of lifting chain	21
6.6 Adjustment of steering wheel chains	21
6.7 Adjustment of side play	22
6.8 Adjusting the Reel Rotator	23
6.9 Cleaning	25
7.0 Fault location key	26
8.0 Good service after purchase	28
8.1 Ordering spare parts	28
8.2 Warranty/Compensation	28
8.3 Service and repair	28
8.4 Warranty	28
8.5 Liability exemption	28



1.0 Before the first lift...

The Reel Rotator is manufactured in accordance with safety directives.

Among the subjects dealt with in this **Instruction Manual** are:



- Proper application
- Physical limitations of the product
- Risks with improper use

Therefore please read this **Instruction Manual** carefully!

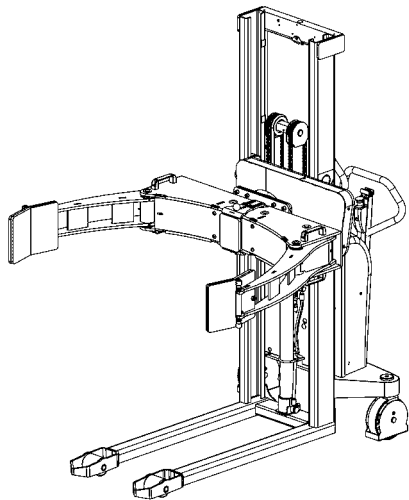
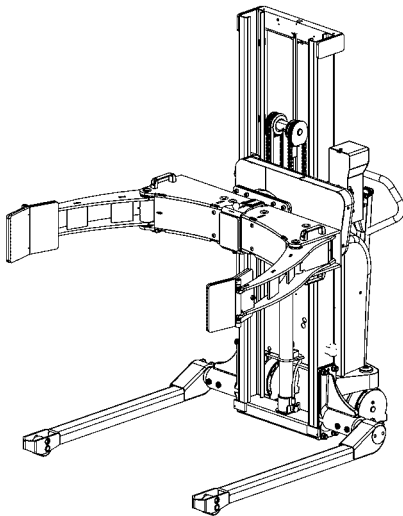



2.0 Functions and identifications

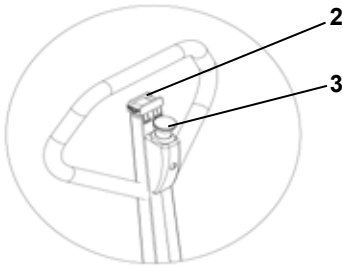

Released position

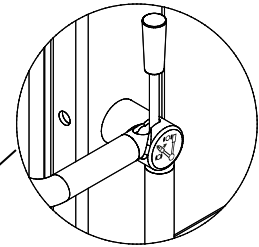

To release the brake:

1. Pull
2. Push

Braked position

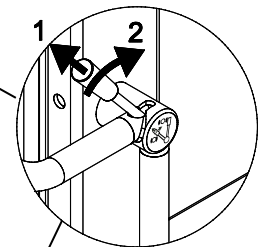

1. Handle
2. Lift/Lower
3. Emergency stop
4. Brake
5. User-Interface
6. Remote control
7. Reel Carriage
8. Gripping arm
9. Name plate, serial number
10. Instrument board :

- Battery indicator
- Charging plug (internal or external charger)
- Plug for extra equipment, 12V maximum 15 Amp

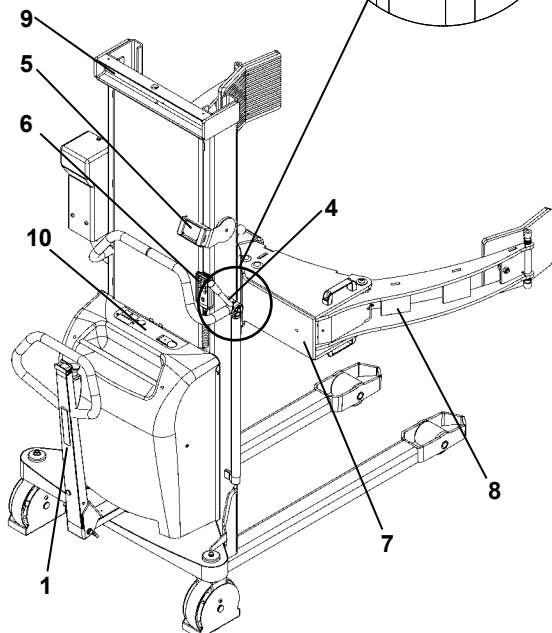



3.0 How to operate Reel Rotator

3.1 Handling of reels

ELFSRRM & ELFSRRE

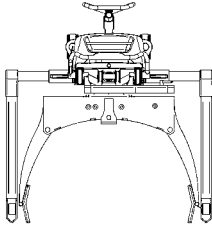

Handling of reels on closed pallets
- Use the Reel Rotator with straddle legs!

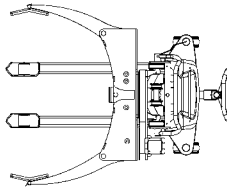
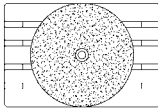

ELFRM & ELFRRE

3.2 Use of the Reel Rotator

3.2.1 ELFRRE, ELFSRRE

Conditions for rotation: Center of the gripping arms is lifted at least:

ELFRRE: 825 mm

ELFSRRE: 750 mm

ELFRRE/ELFSRRE: The load can be rotated 360° with one adjustable stop in every side.

Note: The rotation stops automatically, when the gripping arms are placed horizontally/in position 0°. To continue the rotation function from 0°, the rotation switch has to be released and activated again in the requested rotation direction.

To lower the reel carriage fully, the reel carriage has to be placed in position 0°.

Soft acceleration / deceleration

The Reel Rotator has soft acceleration / deceleration with the following benefits:

- The reel rotation stops precisely.
- The gear is protected, because sudden start / stop are minimised.

3.0 How to operate Reel Rotator

3.2.2 ELFRRM, ELFSRRM - Manual rotation

Conditions for rotation: Center of the gripping arms is lifted at least:

ELFRRM: 825 mm

ELFSRRM: 750 mm



ATTENTION !

Check that the load is placed in the load center and is properly locked before rotating.

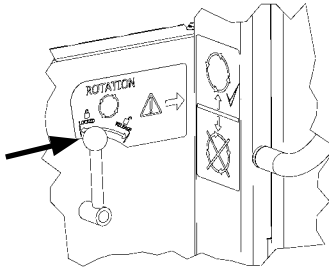

Push the handle to the right - position "Release"

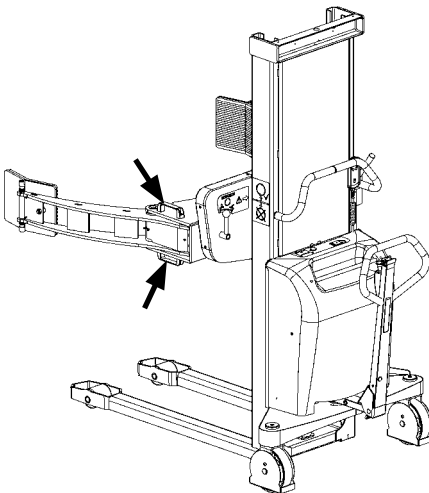

The reel carriage can now be rotated by the gripping handle.

Note: The reel carriage can be locked for each 90°.

3.0 How to operate Reel Rotator

3.3 Remote control MR-1 / Lifting-Lowering-Rotation-Clamping (ELFRRE,ELFSRRE)

The remote control is used for:

- Lifting/lowering the reel carriage/reel
- Rotating the reel carriage/reel
- Clamping/fastening
- Opening/releasing

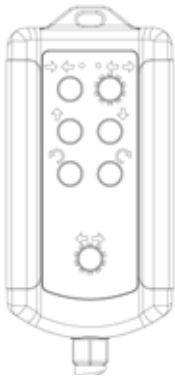

3.4 Remote control MR-1 / Lifting-Lowering-Clamping(ELFRRM,ELFSRRM)

The remote control is used for:

- Lifting/lowering the reel carriage/reel
- Clamping/fastening
- Opening/releasing

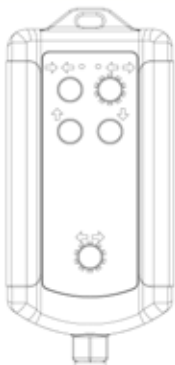

3.0 How to operate Reel Rotator

3.5 Remote control / Lift and lower / Rotation

Lift / Lower

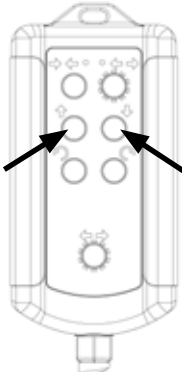

Press ↑ to lift.

Press ↓ to lower.



NOTE! The lowering height with remote control is set from factory - 400 mm to the middle of the gripping arms.

Rotation (ELFRRE/ELFSRRE)



NOTE!

Check that the load is placed in the load center and is properly locked before rotating.

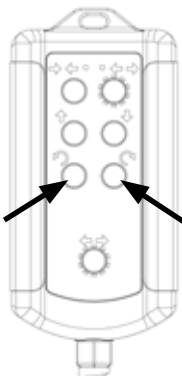

Press to rotate in the direction of the arrow.

The rotation is set to rotate continuously from the factory.

The load can be rotated 360°.

3.0 How to operate Reel Rotator

3.6 Clamping of reels

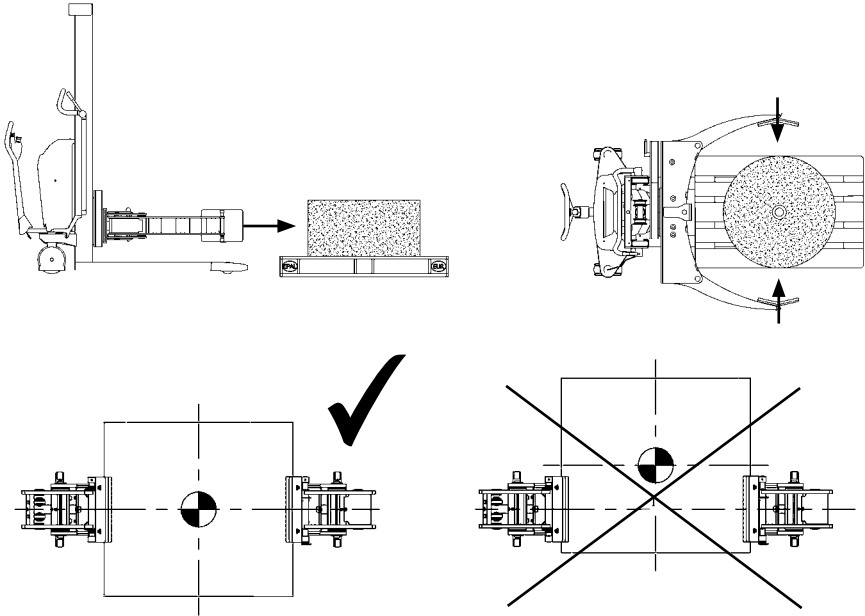

Extra support

For reels from $\text{Ø}800\text{mm}$ to $\text{Ø}1270\text{mm}$ it is possible to use three-points clamping.

By adjusting the shown supporting plate, so that it supports the reel, it can be prevented that the reel moves between the two plates that primarily fasten the reel.

The supporting plate can also be set as stop for a certain reel diameter.

Supporting plate

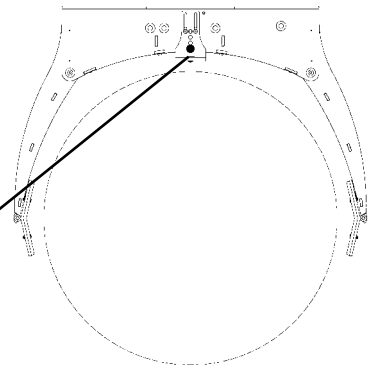

3.0 How to operate Reel Rotator

Clamping

Press “Clamp” until the green lamp(A) is on.
When red lamp lightens (B), the clamping force is not sufficient.

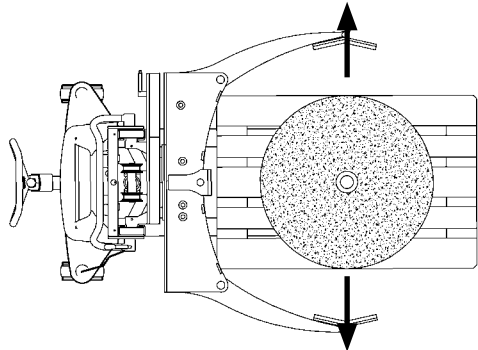
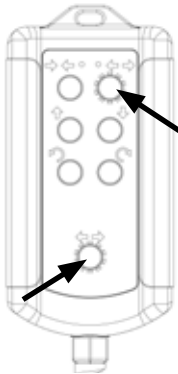
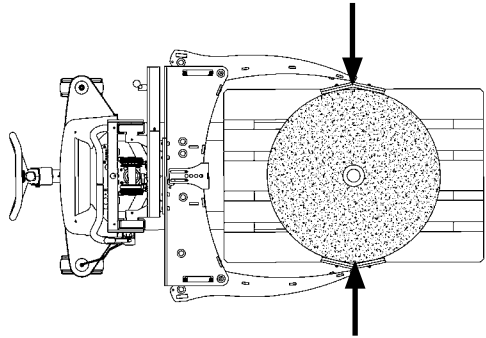
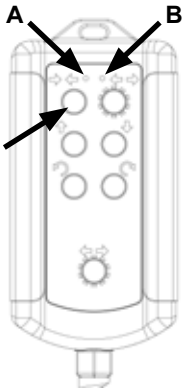

Releasing

Press both buttons at the same time to open the gripping arms.

Note: As a safety precaution, the gripping arms can only be opened, when the lifting system is without pressure.

3.0 How to operate Reel Rotator

3.7 User-Interface LUI-1 Reel Rotator

User-Interface LUI-1 for:

- Setting speed for rotation
- Setting up to three stop position/angles in both rotation directions

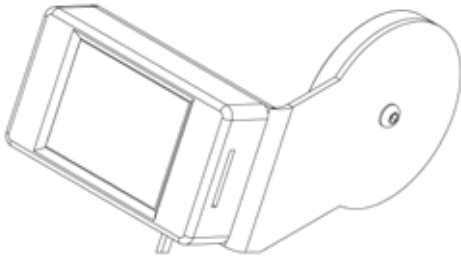

3.8 Setting up User-Interface LUI-1 Reel Rotator

3.8.1 Home display

When starting the machine/deactivating the emergency stop in User-Interface LUI-1, home display is shown.

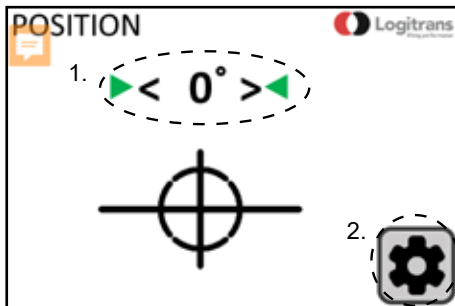

1. Position of the Gripping arms,
 - With green arrow - horizontal (0°)
 - With red arrow - programmed angle

2. Settings

3.0 How to operate Reel Rotator

3.8.2 Display for Setup

At home display, press Setup and the following is shown.

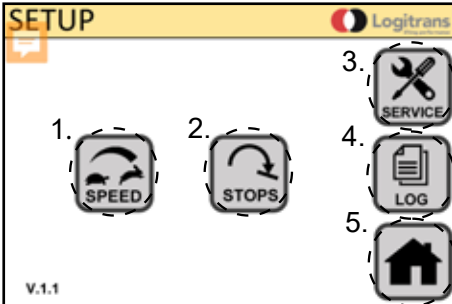

1. Speed (SPEED)
2. Angle stop (STOPS)
3. Service (SERVICE)
4. Output data (LOG)
5. Home display (HOME)

3.8.3 Setting of rotation speed

At the Setup display, press “SPEED” and the following is shown.

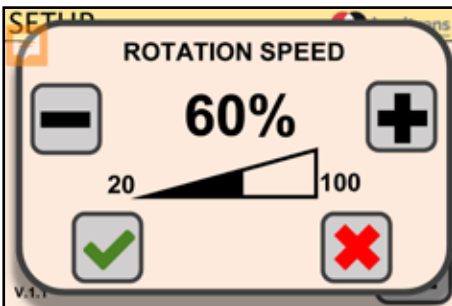

1. Use \pm to adjust the speed.
2. Use \checkmark / \times to accept/cancel the choice and return to Setup display.

3.0 How to operate Reel Rotator

3.8.4 Setting of stop position

From the factory, the reel carriage is set to rotate continuously. When the reel carriage have rotated 360°, the machine stops rotating. If you want rotation to continue, it is necessary to release/press the rotation switch on the remote control again.

It is possible to set up to three stop positions/angles for rotation in both directions.

If the machine is set with one or more stop positions/angles, the machine cannot rotate further than the last set stop position/angle.

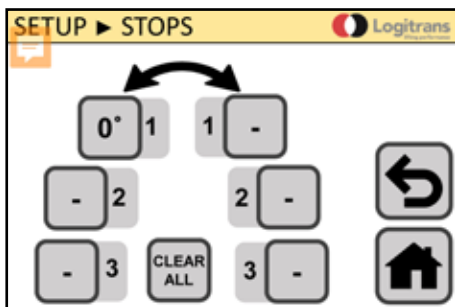

At home display press Setup, and afterwards STOPS, and the following is shown.

At the Stops display, press on the first stop in the requested direction, and the following is shown.

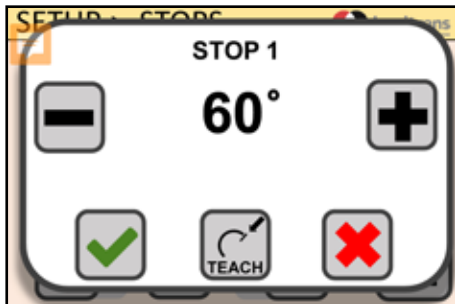

1. Use $+$ / $-$ to choose the size of the angle or use TEACH to choose actual position.
2. Use \checkmark / \times to accept/cancel choice and return to Stops display.
3. At the Stops display choose the next stop position/angle and repeat the procedure.

3.8.5 Deleting stop positions

At the Stops display, press "CLEAR ALL" to delete all set stop positions/angles.



4.0 Optimum safety

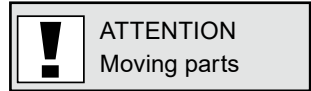
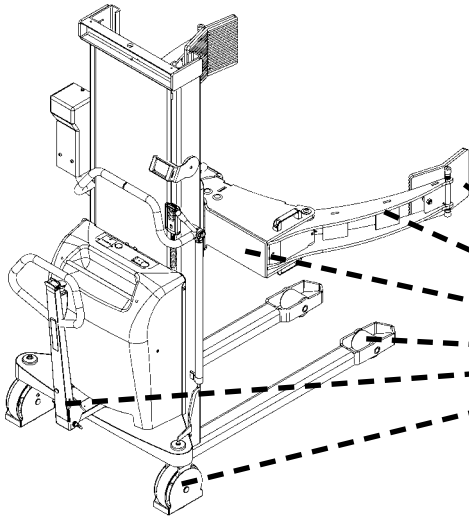

4.1 Safety regulations

- Never walk under a raised load!
- Never stand between the gripping arms!
- Before lowering the reel carriage, make certain that no foreign elements can hinder the free lowering of the reel carriage
- The Reel Rotator is designed for use on an even and level floor
- During transport the reel carriage shall be raised as little as possible
- Transport with raised reel carriage should be made over the shortest possible distances and at low speed
- Do not exceed the permitted capacity of the product.
- Check that the chains lift equally. They shall be equally tight when the reel carriage is loaded
- Chains and chain bolts must not be damaged. Chains that have become permanently stretched (max. 2 % of original length) must be scrapped



4.0 Optimum safety

4.2 Rotation range

Standard version

The load can be rotated, when the turning point of the reel carriage is raised more than 750 mm (ELFSRRM/ELFSRRE) and more than 825 mm (ELFRRM/ELFRRE). Below this range, it is only possible to raise/lower the reel carriage in position 0°.

4.3 Driving loaded

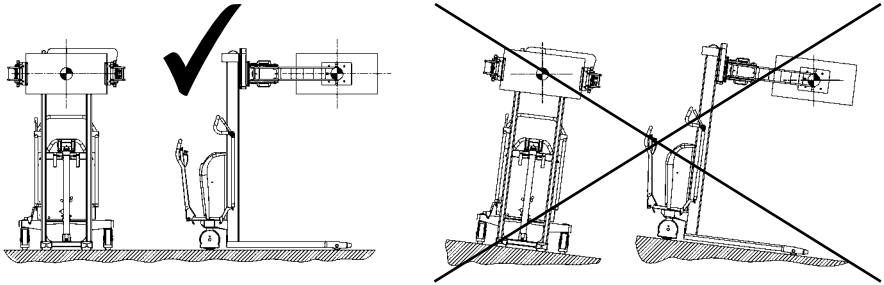

The Reel Rotator is designed for use on even and level floor. During transport the reel carriage shall be raised as little as possible. Transport with raised reel carriage should be made over the shortest possible distances and at low speed.

4.0 Optimum safety

4.4 Rotation with load

NOTE! Rotation is only allowed to take place, if the Reel Rotater is placed on an equal floor.

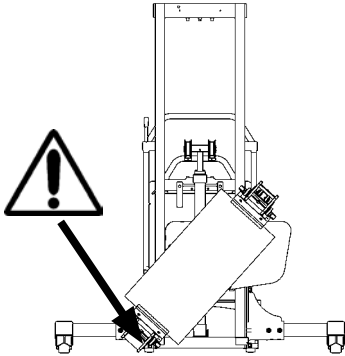

When rotating reels, the operator needs a full overview of the whole working area, so that the rotation movement can be stopped before the reel touches the floor, the items or persons in the working area.

4.5 Emergency stop

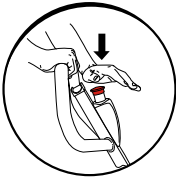

The Reel Rotator has an emergency stop. When activating the emergency stop, the main current supply is switched off. The movement of the reel carriage stops immediately when activating the emergency stop.

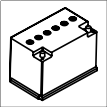

5.0 There must be a current supply...

5.1 Fuses - replacement

There are five fuses in the electrical circuit:

- 10 Amp fuse in the control current circuit
- 20 Amp fuse (plug for extra equipment on the instrument board)
- 20 Amp fuse for built-in charger
- 100 Amp fuse in the main supply from battery
- 40 Amp fuse for rotation

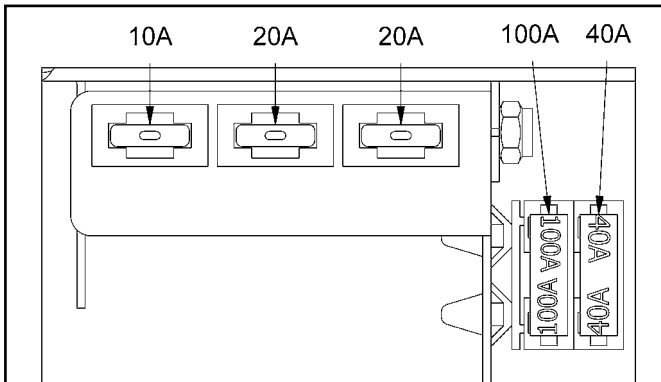

Replacement:

The old fuse is to be removed and replaced by a new one of the same size.

Find out why the fuses blow!

5.2 Wiring connections

Many operational disturbances are caused by bad connections in the electrical circuit. Make sure that the connections are in order.

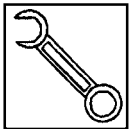

Check connections regularly for damage at insulating caps or bad connections at plugs etc. Verdigris must be removed from cable plugs. Keep all screw/nut connections tight.



6.0 Long live Reel Rotator

Regular inspection and the replacement of worn or defective parts in good time will prolong the life of the Reel Rotator. "Prevention is better than repair", therefore ensure:

- That the battery is fully charged every time
- Correct usage
- Regular cleaning
- Periodic safety and service inspection

For safety reasons please check the below every 3 month:

- Tighten loose screw and nuts
- Check that there are no cracks, fractures and deformations in the bearing construction
- Wearing parts, such as brakes, wheels and bearings, are adjusted and exchanged continuously



6.1 Lubrication and hydraulic oil

Under normal operation conditions the Reel Rotator requires no lubrication. All ball bearings are sealed and lubricated for life, and moving parts have self-lubricating bearings or are treated with grease.

The hydraulic system is filled with hydraulic oil of viscosity class ISO VG 15. An additive is added to the oil. The concentrate reduces friction and wear and protects against corrosion. Pre-mixed hydraulic oil with additive is available from the dealer. The oil is suitable for use in the temperature range -10 to +50° C. A thinner oil is recommended for temperatures lower than -10° C (if necessary, contact your dealer).

6.2 Oil change

Draining the oil:

1. Bring the unloaded reel carriage down to the lowest position.
2. Most of the oil can be drained by loosening the hydraulic hose union and briefly activating the hydraulic pump with the switch.
3. The remaining oil can be drained from the oil tank by removing the tank.

Oil filling:

4. Fill oil through the filling hole on the tank.
5. Oil quantity: ELFRRM 1750 & ELFSRRM 1750 approx 3 liter
ELFRRE 1750 & ELFSRRE 1750 approx 3 liter
6. Refit the filling cap and bleed the system (6.3).

6.0 Long live Reel Rotator

6.3 The hydraulic pump and the gear motor

The hydraulic pump has a S3 “periodic intermittent duty” of 10%. This means that the pump in total is allowed to operate 1 minute for a period of 10 minutes.

Note! If the pump operates more than 10%, the motor will be damaged due to superheating.

Bleeding the hydraulic system

With a load of 50-100 kg, the reel carriage must be raised and lowered to top and bottom position 2-3 times.

Gear motor of the Reel Rotator

The gear motor has a “short time under constant load” of 10 minutes (S2=10 minutes). This means that the motor is allowed to operate with the maximum load for 10 minutes. Hereafter it has to be cooled down to normal temperature.

Note! The motor will be damaged by superheating, if it operates for a longer time or if it is not cooled down.

6.4 Reel carriage adjustment

Two of the rollers on the reel carriage are mounted on eccentric pins, so that they can be adjusted. The adjustable rollers are at the top.

1. Loosen screw (pos. 91) (key width 5 mm).
2. Eccentric pins (pos. 56) (key width 8 mm) can now be turned to give the necessary reel carriage adjustment.
3. Adjustment must be made on both sides to ensure uniform loading of the rollers.

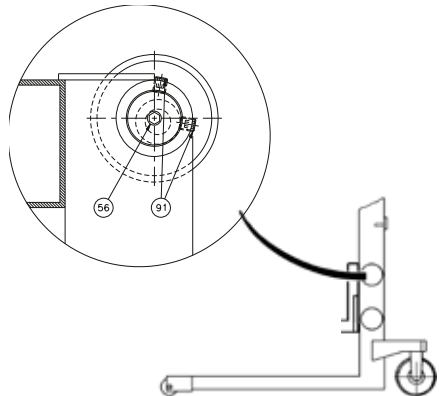

6.0 Long live Reel Rotator

6.5 Adjustment of lifting chain

The chains shall be adjusted so that:

- They lift equally
- They are equally tight
- The lifting movement has to stop in the cylinder, before the mast rolls touch the top stop.

After having adjusted the chains:

- Check that the reel carriage is placed horizontally.

The nuts (pos. 18) are to be adjusted (nut M12, key width 19 mm).

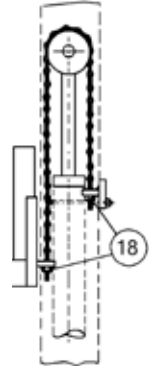

6.6 Adjustment of steering wheel chains

- Set the handle in its middle position.
- Adjust the nuts (1, 2, 3 and 4) and bring the wheels into parallel.

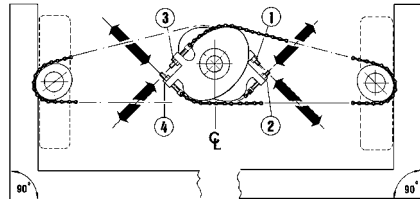

6.0 Long live Reel Rotator

6.7 Adjustment of side play

1. Screw (A) is loosened counter-clockwise, until resistance disappears.
2. Turn the screw clockwise, until resistance appears. The following 1.5 to 2.5 turns of the screw will be a tightening of the spring (C).
3. When a larger resistance appears, make 0.25 turn counterclockwise, and the counter nut (B) will be tightened.
4. Lift the carriage to the top position, and when lowering it has to slide to the bottom. If this is not the case, loosen screw A, make c. 0.5 turn counterclockwise and repeat point 4.

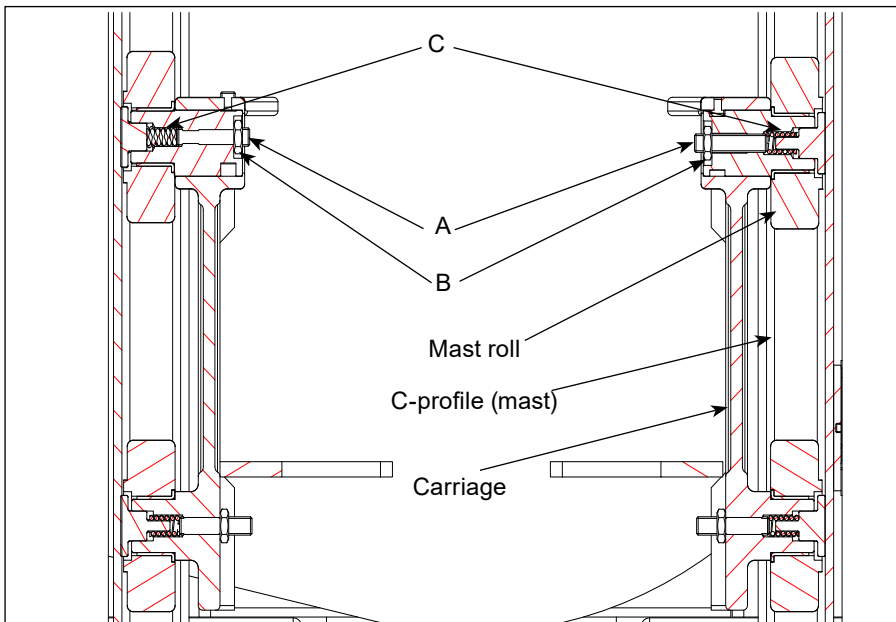

6.0 Long live Reel Rotator

6.8 Adjusting the Reel Rotator

Tensioning the chains (ELFRRE&ELFSRRE)

When the unloaded reel carriage can be tilted manually approx. 2 cm, measured at the rear carriage, the chains should be tensioned.

This is done by:

1. Removing the cover from the reel carriage.
2. Loosening the gear motor (A1)
3. Loosening chain wheel (B1)
4. Turning the nut (B2), so that the large chain is tensioned, until the slack is about 5 mm.
5. Tightening the chain wheel (B1)
6. Tightening the nuts for the gear motor (A2), so that the chain is tensioned, until the slack is about 2-3 mm. Tighten the nuts (A1) again.
7. Replace the cover.

NOTE!

Check the large chain is tightened correctly in the whole rotation area after adjusting the chains.

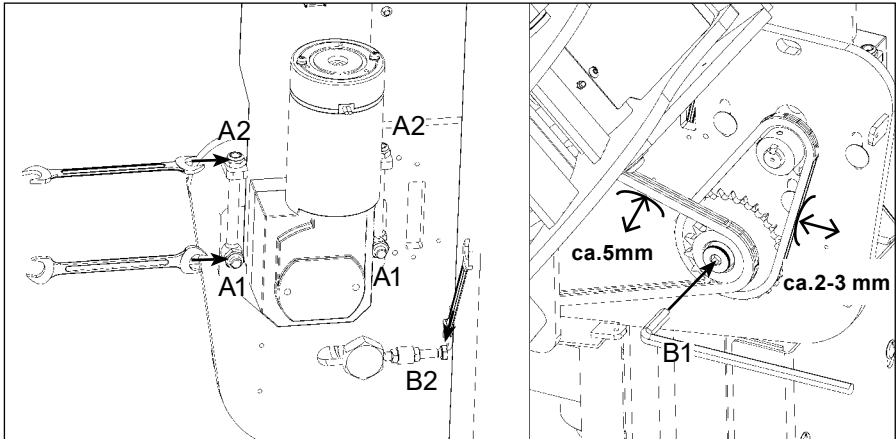

6.0 Long live Reel Rotator

Lubrication

Support bolts

To support the thrust ring, two support bolts (A) are placed behind the ring. The bolts must only just touch the ring, and the back of the ring has to be lubricated with grease, so that the bolts slide smoothly.

Chains

The chains of the Reel Rotator have to be lubricated at the yearly service check.

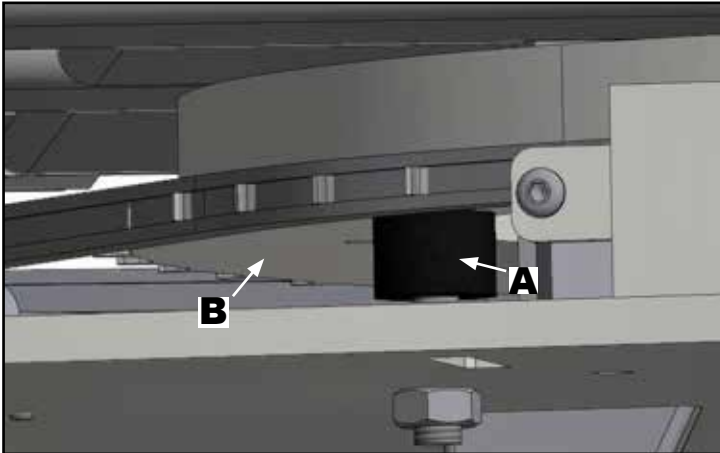

6.0 Long live Reel Rotator

6.9 Cleaning



When cleaning the Reel Rotator, do not direct the jet onto bearings, seals and electric components. Otherwise the grease will be washed out and the life of the equipment shortened.

Cleaning of the plastic screen (polycarbonate)

The screen is to be washed with slightly warm water added a neutral cleaning material, and afterwards washed with clean water.

Use a soft sponge, a woollen cloth or a wash leather.



Never use sharp objects or solvent cleaners when cleaning.



7.0 Fault location key

When the Reel Rotator is used every day, adjustments and the replacement of worn parts might be necessary. Adjustments and minor repair can easily be made on the spot. Major repairs should, however, be carried through by the dealer who has a well-trained staff and the necessary special tools.



**Before asking the dealer for assistance...
...try the fault location key!**

SYMPTOMS AND OBSERVATIONS

- A** Pump does not run when the UP button is pressed _____
- B** Truck does not lift when the UP button is pressed _____
- C** Truck does not lift to max. height _____
- D** The reel carriage lowers after being raised _____
- E** The reel carriage does not lower when DOWN button is pressed _____
- F** The reel carriage cannot be lowered fully _____
- G** Truck is unable to lift the max. loadt _____
- H** Truck lifts slowly _____
- I** The reel carriage does not lift horizontally _____
- J** Steering wheel does not drive evenly _____

Cause

Mending

	Oil deficiency	See point 6.1/6.2
	Battery discharged	See separate instruction
	Fuse blown 10 Amp or 100 Amp	See point 5.1
	Cables defective	See point 5.2
	Max. load exceeded	See point 4.1
	Air in hydraulic system	See point 6.3
	Pressure relief valve incorrectly adjusted	Contact the dealer
	Leakage in hydraulic system Visible oil leakage	Contact the dealer
	Reel carriage needs adjustment	See point 6.4/6.5/6.7/6.8
	Solenoid or check valve defective	Contact the dealer
	Defective valves in pump	Contact the dealer
	Steering wheel out of adjustment	See point 6.6
	Defective solenoid valve	Contact the dealer

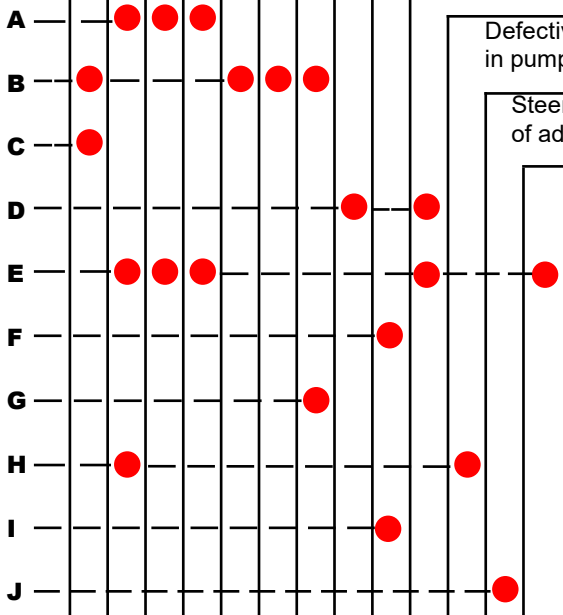

**If the problem cannot be solved
by using the fault location key...
...please contact
your dealer!**



8.0 Good service after purchase

8.1 Ordering spare parts

The correct spare parts are obtainable from your dealer.

When ordering, please state:

- Serial number of the product
- Type and width/length of the product
- Spare part no. Please find spare part no. on **www.logitrans.com**

8.2 Warranty/Compensation

Spare parts delivered during the warranty period will be invoiced. A credit note will be sent immediately after we have received and tested the defective parts and found that the warranty conditions have been met.

8.3 Service and repair

You should be able to make adjustments and perform minor repairs on the spot. However, major repairs should be left to the dealer who has well-trained personnel and the necessary special tools.

8.4 Warranty

The warranty covers material and assembly defects which, subject to inspection by us or our representative, are deemed to be faults or deficiencies that prevent normal use of the parts concerned. Such affected parts shall be sent to your Logitrans dealer carriage paid within the warranty period in force at the time in question, together with a copy of the documentation for the service performed (B0284 - see the back page). The warranty does not cover normal wear and adjustments. The warranty period is based on singleshift working.

The warranty shall no longer apply if

- the product has been used incorrectly,
- the product is used in environments for which it was not designed,
- the product has been overloaded,
- replacements of parts have been made incorrectly or original parts have not been used and consequential damages have arisen,
- the product is changed or accessories, not being approved by Logitrans, are used.
- it can not be proved that a qualified technician has performed the service check according to the requirements stated in the instruction manual (see the back page).

8.5 Liability exemption

The manufacturer accepts no responsibility for personal injury or material damage arising from deficiencies, defects or improper usage. The manufacturer accepts no responsibility for lost earnings, operating losses, lost time, lost profits or similar indirect losses incurred by the purchaser or a third party.

Periodic service and safety inspection

Service check is required once each year.

Safety inspection should be performed by the dealer or other qualified persons at least once each year, unless local regulations state otherwise.

The inspections are to be performed on the basis of form no. B0342 and proved on form no. B0284. Forms and instructions for the inspections are available at your dealer.

S 995

ELFRR-EN

03042020/2