

# REEL ROTATOR SELFRRM/SELFRRM, SELFRRR/SELFRRR

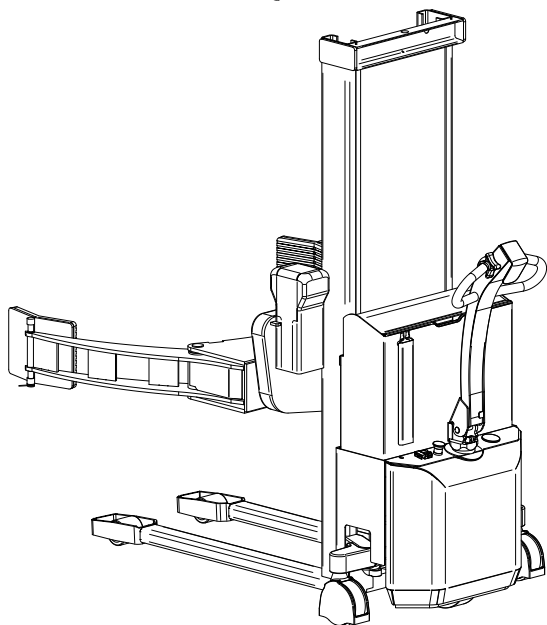
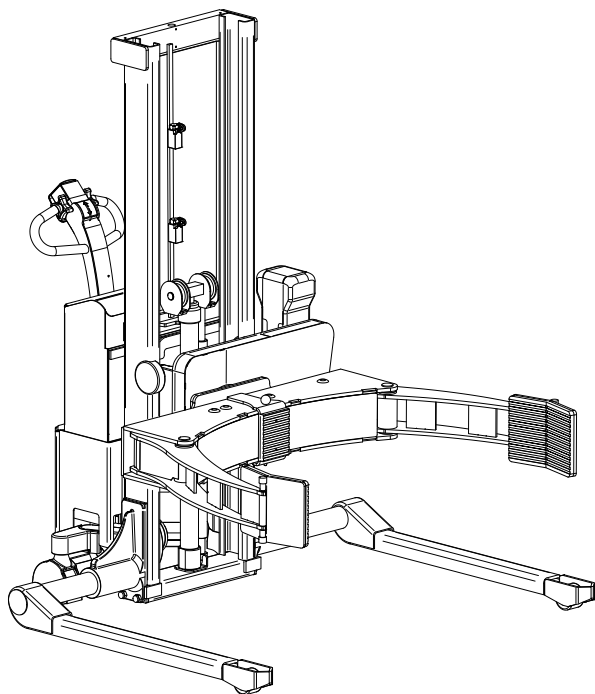

## EU DECLARATION CONFORMANCE

Manufacturer: **Logitrans A/S**  
Address: **Hillerupvej 35**  
**6760 Ribe**  
**Denmark**

hereby declares that:

machine:           Product group:           **Reel Rotator**

Type:                           **SELFRE1002/SEFSRRE1002**

Production year/  
Serial no:

- a) has been manufactured in conformance with the stipulations of the:
- **Directive no. 2006/42/EC**
  - **Directive no. 2014/30/EC**
  - **Directive no. 2014/35/EC**
- b) has been manufactured in conformance with the stipulations of the standard:
- **EN 3691-5**

Responsible for the technical dossier:

Name:           **Gitte Kirkegaard**  
Address:       **Hillerupvej 35, DK-6760 Ribe**

Signature:



Gitte Kirkegaard, CEO, Logitrans A/S

Ribe, 25.04.2019



# Contents

<b>1.0 Before the first lift...</b>	4
<b>2.0 Functions and identifications</b>	5
<b>3.0 How to operate the Reel Rotator</b>	7
3.1 Handling of reels	7
3.2 Use of the Reel Rotator (SELFRRRE/SELFSRRE)	7
3.3 Handle functions	9
3.4 Personal safety	11
3.5 Clamping of reels	12
3.6 Electric rotation (SELFRRRE/SELFSRRE)	14
3.7 Adjusting of rotation stop (SELFRRRE/SELFSRRE)	15
3.8 Setting the speed (SELFRRRE/SELFSRRE)	15
3.9 Reset (SELFRRRE/SELFSRRE)	15
<b>4.0 Optimum safety</b>	16
4.1 Rotation range	17
4.2 Driving loaded	18
4.3 Rotation with load	18
4.4 Emergency stop	18
<b>5.0 There must be a current supply...</b>	19
5.1 Fuses - replacement	19
5.2 Wiring connections	19
<b>6.0 Long live Reel Rotator</b>	20
6.1 Lubrication and hydraulic oil	20
6.2 Oil change	21
6.3 Reel carriage adjustment	22
6.4 Adjustment of lifting chain	22
6.5 The hydraulic pump and gear motor	23
6.6 Cleaning	23
6.7 Adjustment of side play	24
<b>7.0 Adjusting the Reel Rotator</b>	25
7.1 Tensioning the chains	25
7.2 Adjusting the switch (SELFRRRE/SELFSRRE)	26
7.3 Lubrication	26
<b>8.0 Fault location key</b>	27
<b>9.0 Good service after purchase</b>	29
9.1 Ordering spare parts	29
9.2 Warranty/Compensation	29
9.3 Service and repair	29
9.4 Warranty	29
9.5 Liability exemption	29



## 1.0 Before the first lift...

The **Reel Rotator** is manufactured in accordance with safety directives.

Among the subjects dealt with in this **Instruction Manual** are:



- Proper application
- Physical limitations of the product
- Risks with improper use

- Therefore please read this **Instruction Manual** carefully!

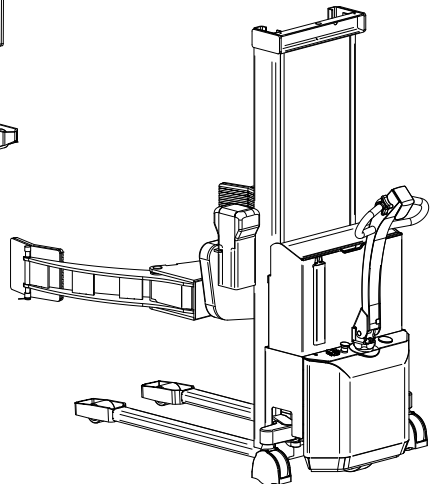
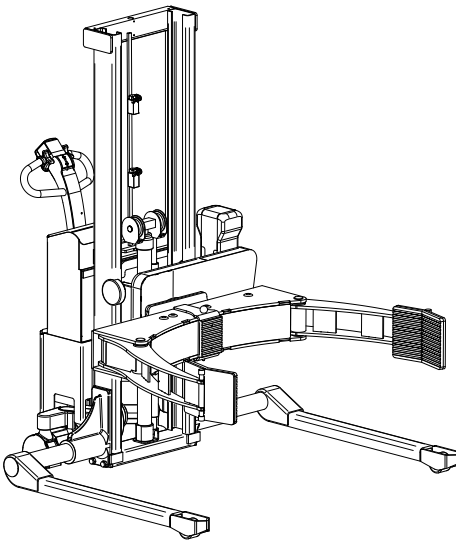

## 2.0 Functions and identifications

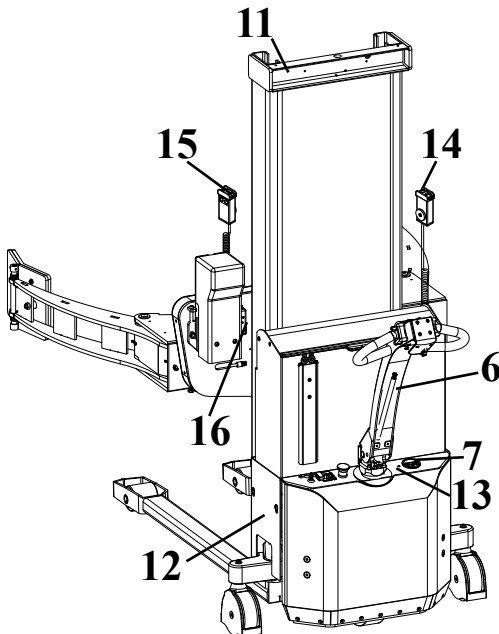
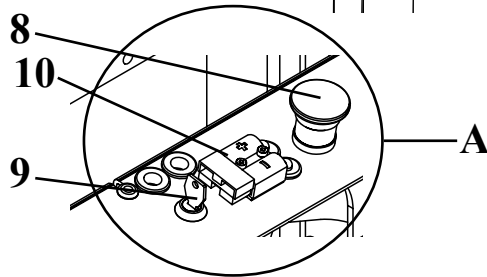
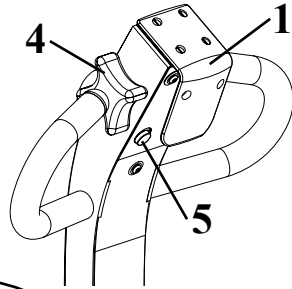
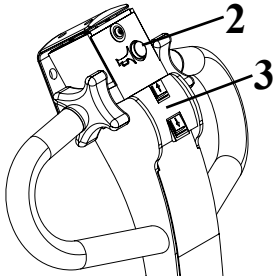

1. Safety switch
2. Horn
3. Lift/Lower
4. Forward/Reverse
5. Multiflex function
6. Handle
7. Battery indicator/ hour counter
8. Emergency stop
9. Ignition key
10. Charger plug (external charger)
11. Type plate
12. Serial number, on chassis behind the plate
13. Charging lamps
14. Remote control for clamping
15. Remote control for rotation
16. Programming of rotation

## 2.0 Functions and identifications

---

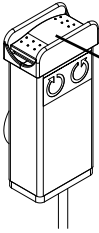

Clockwise/  
counter-  
clockwise

### **Remote control for rotation (SELFRE/SELFSRRE):**

The remote control is used when:

- Rotating the reel carriage
- Setting tilt stop in both directions: See point 3.7
- Setting rotation speed: See point 3.8

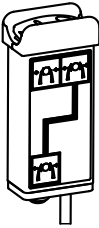

### **Remote control for clamping:**

The remote control is used when:

- Clamping/fastening
- Opening/releasing



## 3.0 How to operate Reel Rotator

### 3.1 Handling of reels

SELSRRE

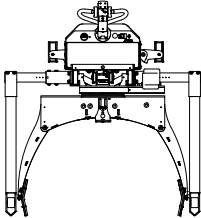

**Handling of reels on closed pallets**

- Use the Reel Rotator with straddle legs!

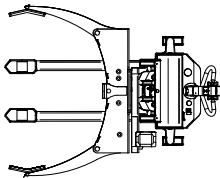
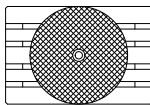

SELSRRE

### 3.2 Use of the Reel Rotator (SELSRRE/SELSRRE)

**Conditions for rotation:** Center of the gripping arms is lifted at least:

SELSRRE: 825 mm

SELSRRE: 750 mm

The load can be rotated 355° with one adjustable stop in every side.

**Note:** The rotation stops automatically, when the gripping arms are placed horizontally/in position 0°. To continue the rotation from 0°, the rotation switch has to be released and activated again in the requested rotation direction.

To lower the reel carriage fully, the reel carriage has to be placed in position 0°.

#### **Soft acceleration / deceleration**

The Reel Rotator has soft acceleration / deceleration with the following benefits:

- The reel rotation stops precisely.
- The gear is protected, because sudden start / stop are minimised.

### 3.0 How to operate the Reel Rotator

---

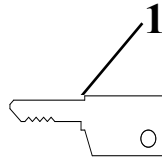
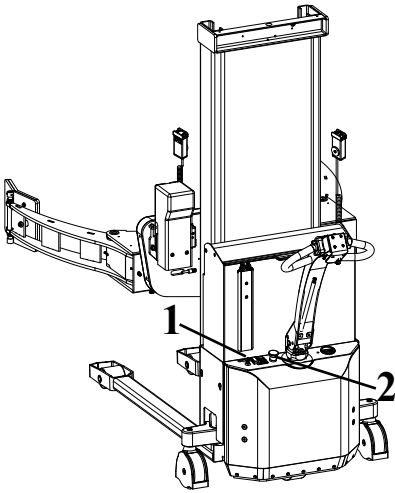

Insert key (1) and turn clockwise to switch on control current ready for function activation.

**!** Note!!! Emergency stop (2) must not be activated.



### 3.0 How to operate the Reel Rotator

#### 3.3 Handle functions

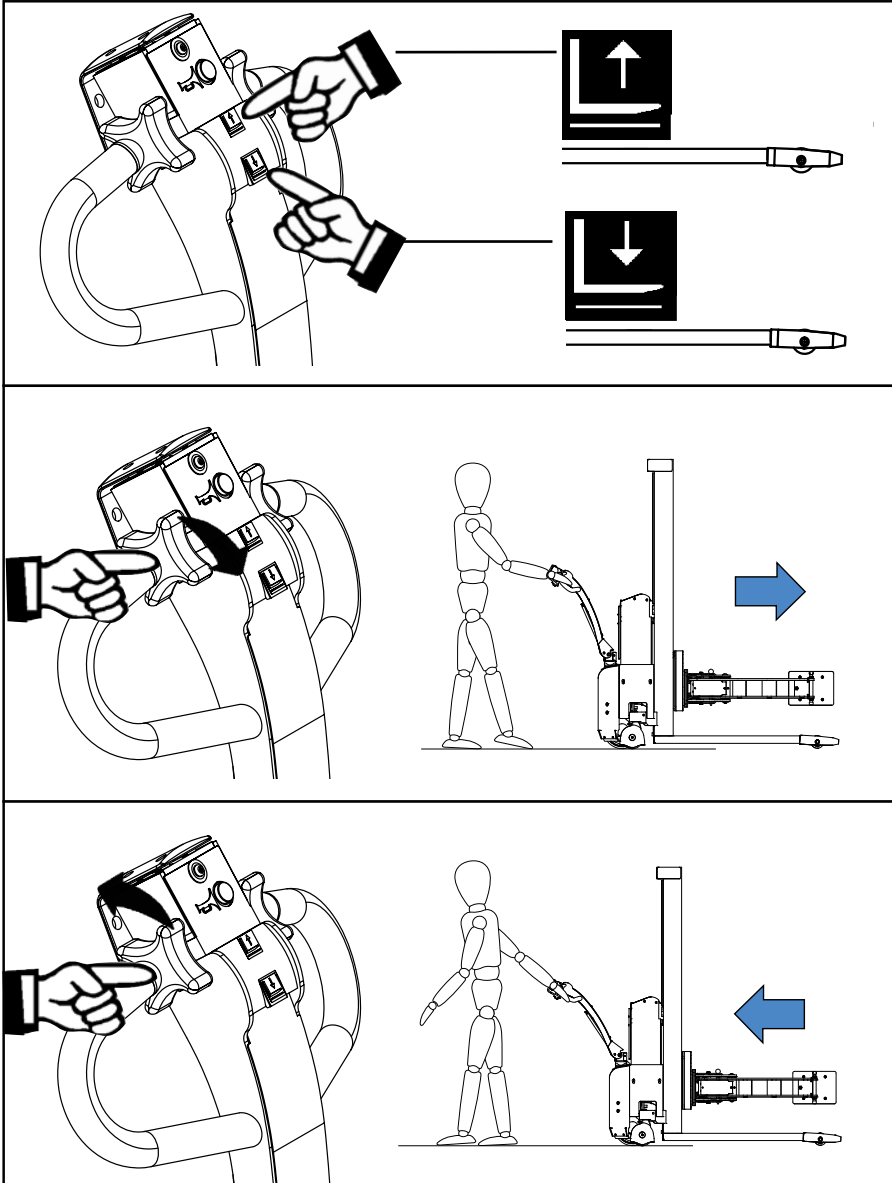

### 3.0 How to operate the Reel Rotator

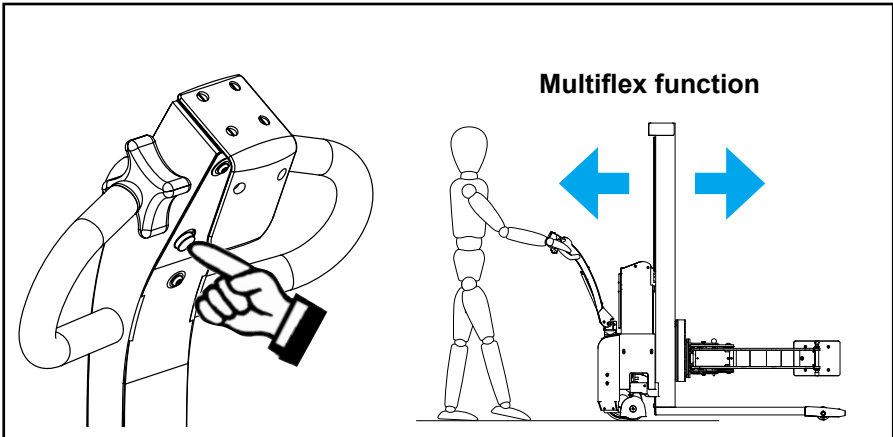

**Multiflex function**

**Multiflex function**

- This function makes it possible to drive the Reel Rotator, even though the handle is in its upright, braked position (B)
- The function requires two-handed operation, i.e. it must be performed deliberately
- The function facilitates manoeuvring in confined areas.

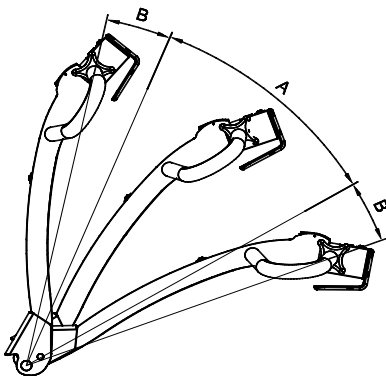

The control functions of the Reel Rotator are located in the handle  
- The functions are dependent on the positions of the handle!

**Position A: Drive position**

Drive current on  
Brake deactivated

**Position B: Stop/Brake/  
Emergency Stop**

Drive current off  
Brake activated

### 3.0 How to operate the Reel Rotator

---

#### 3.4 Personal safety

The safety switch on the end of the handle ensures that the operator cannot be trapped when the Reel Rotator is reversed.

**When the safety switch is activated, the Reel Rotator will change direction, move forwards and stop.**

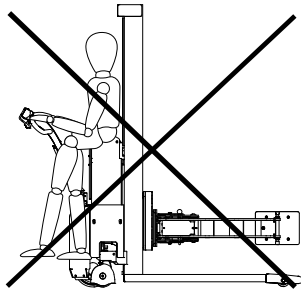
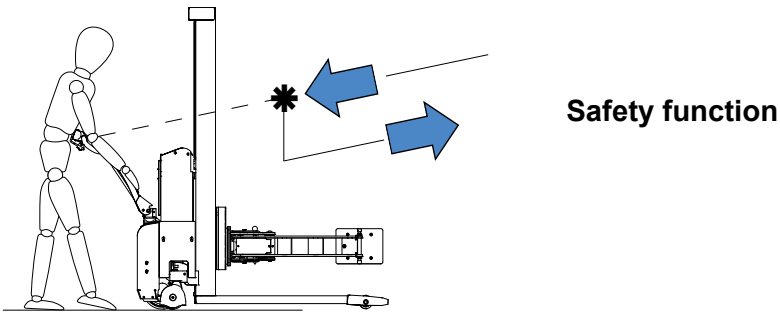

## 3.0 How to operate the Reel Rotator

### 3.5 Clamping of reels

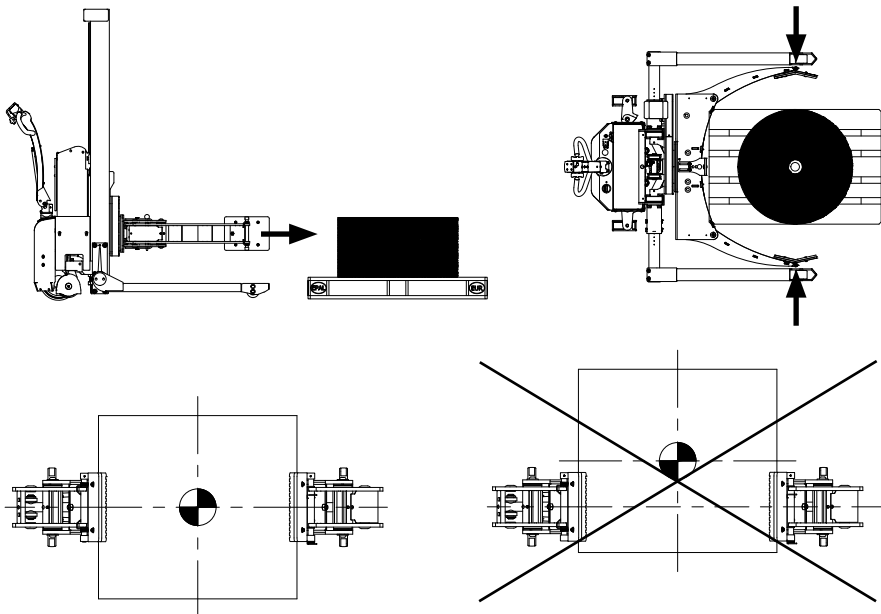

### Extra support

For reels from  $\varnothing 800\text{mm}$  to  $\varnothing 1270\text{mm}$  it is possible to use three-points clamping.

By adjusting the shown supporting plate, so that it supports the reel, it can be prevented that the reel moves between the two plates that primarily fasten the reel.

The supporting plate can also be set as stop for a certain reel diameter.

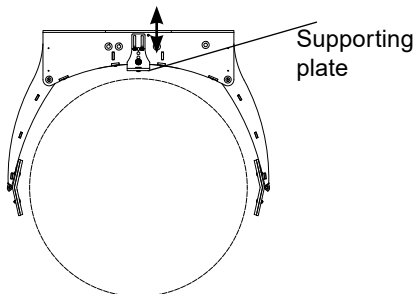

### 3.0 How to operate the Reel Rotator

---

#### Clamping:

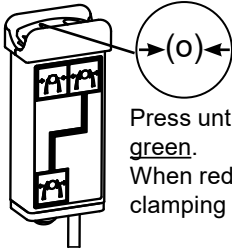

Press until the lamp lightens green.  
When red lamp lightens, the clamping force is not sufficient.

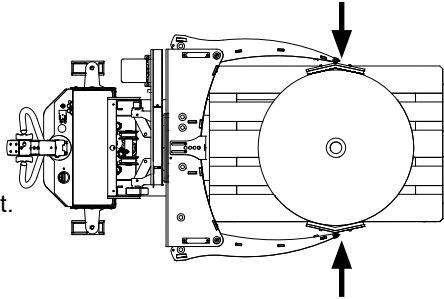

#### Releasing:

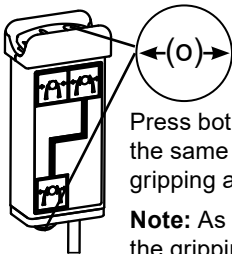

Press both buttons at the same time to open the gripping arms.

**Note:** As a safety precaution, the gripping arms can only be opened, when the lifting system is without pressure.

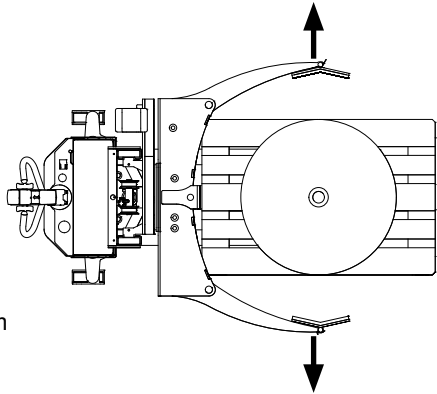

## 3.0 How to operate the Reel Rotator

---

### 3.6 Electric rotation (SELFRR/SELSRRE)



**ATTENTION** Check that the load is placed in the load center before rotating.

Use the remote control for the rotation:

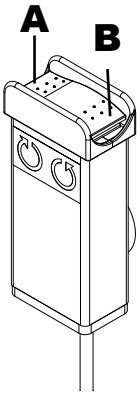

Press “A” to rotate clockwise (seen from position behind the handle).

Press “B” to rotate counterclockwise (seen from position behind the handle).

From the factory the rotation is preset to stop 90° to each side. The load can as maximum be rotated 355° with one adjustable stop in every side.

**Note:** The load has to be placed in position 0°, before the load can be lowered fully.

## 3.0 How to operate the Reel Rotator

---

### 3.7 Adjusting of rotation stop (SELFRE/SELFSRRE)

The reel carriage is factory-set to stop in 90°. If another setting is required, it can be set electronically to stop in different angles.

- 1) The reel carriage is placed in position 0°.
- 2) Short pressure on the switch A activates the setting procedure. The controller gives a signal (one beep).
- 3) The reel carriage is placed in the requested angle.
- 4) When the reel carriage has reached the requested angle, the controller will give signal after three seconds (one beep), when the position has been stored.

The procedure is repeated to set the stop in the other side.



### 3.8 Setting the speed (SELFRE/SELFSRRE)

- 1) The reel carriage is placed in position 0°.
- 2) The switch (A) is pressed three seconds, and two short beeps will be given. The switch is released and the speed is set by activating the remote control.

**Clockwise:** Reducing the speed

**Counter-clockwise:** Increasing the speed

**Note:** Maximum rotation speed (0-355°): 30 sec.

- 3) 3 seconds after releasing the switch on the remote control, the controller will give signal (two beeps), indicating that the requested speed has been stored.

### 3.9 Reset the settings (SELFRE/SELFSRRE)

- 1) The reel carriage is placed in position 0°.
- 2) Press switch (A), until five beeps are given. The switch is released and the controller is set to maximum speed and stops at 45°.



## 4.0 Optimum safety

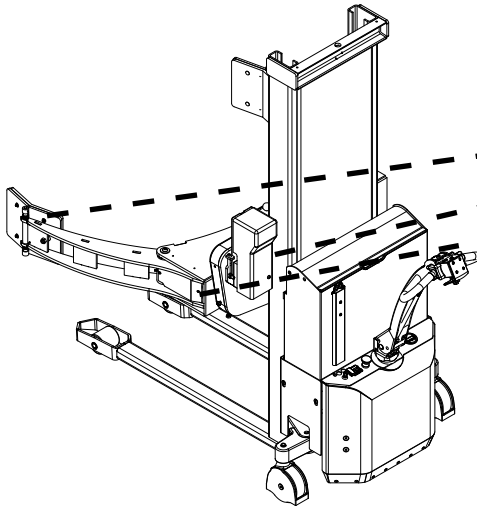

### Safety regulations

- Never walk under a raised load!
- Never stand between the gripping arms!
- Before lowering the reel carriage, make certain that no foreign elements can hinder the free lowering of the reel carriage
- The Reel Rotator is designed for use on an even and level floor
- During transport the reel carriage shall be raised as little as possible
- Transport with raised reel carriage should be made over the shortest possible distances and at low speed
- Check that the chains lift equally. They shall be equally tight when the reel carriage is loaded
- Chains and chain bolts must not be damaged. Chains that have become permanently stretched (max. 2 % of original length) must be scrapped





## 4.0 Optimum safety

---

### 4.1 Rotation range

#### Standard version

The load can be rotated, when the turning point of the reel carriage is raised more than 750 mm (SELFSSRRE) and more than 825 mm (SELFRRRE). Below this range, it is only possible to raise/lower the reel carriage in position 0°.



#### **Bottom stop (SELFRRRE/SELFSSRRE)**

Adjusted with the following turning point above the floor:

SELFSSRRE: 750 mm

SELFRRRE: 825 mm

## 4.0 Optimum safety

---

### 4.2 Driving loaded

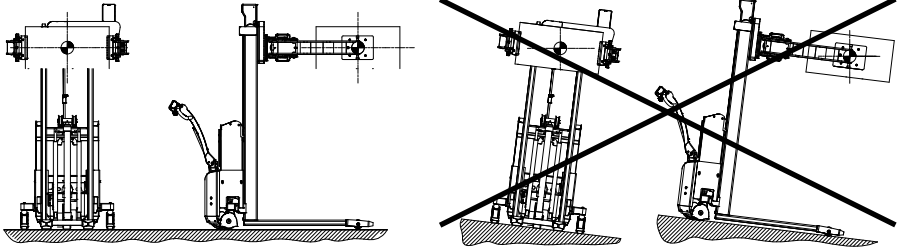

The load centre is never allowed to exceed the centre line of the wheels. The driving speed is reduced when lifting the forks above 400 mm. During transport with load, the reel carriage shall be raised as little as possible.

### 4.3 Rotation with load

**NOTE!** Rotation is only allowed to take place, if the Reel Rotater is placed on an equal floor.

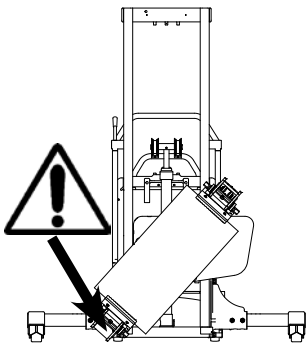

When rotating reels, the operator needs a full overview of the whole working area, so that the rotation movement can be stopped before the reel touches the floor, the items or persons in the working area.

### 4.4 Emergency stop

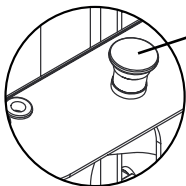

The product has an emergency stop. When activating the emergency stop, the main current supply is switched off.

- The movement of the reel carriage stops immediately.
- Driving with the truck stops immediately.
- The emergency stop is deactivated by turning the switch to the right.

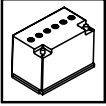

## 5.0 There must be a current supply...

### 5.1 Fuses - replacement

There are five fuses in the electrical circuit:

- 40 Amp** fuse for rotation
- 100 Amp** fuse for the hydraulic pump
- 100 Amp** fuse in the main supply from battery
- 10 Amp** fuse in the control current circuit
- 20 Amp** fuse for built-in charger

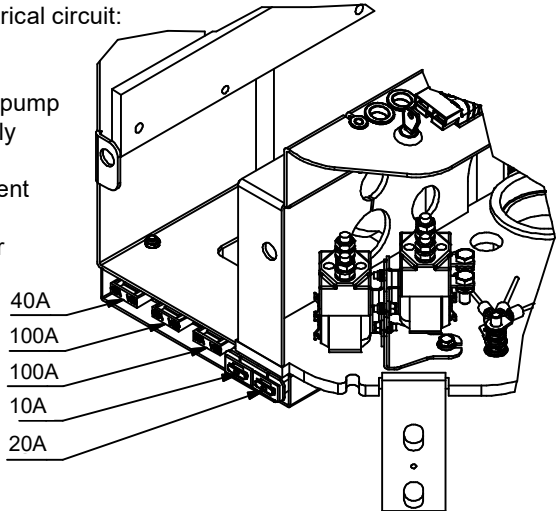

#### Replacement:

The old fuse is to be removed and replaced by a new one of the same size.

**Find out why the fuses blow!**

### 5.2 Wiring connections

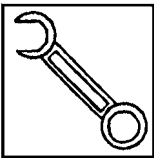

**Many operational disturbances are caused by bad connections in the electrical circuit. Make sure that the connections are in order.**

Check connections regularly for damage at insulating caps or bad connections at plugs etc. Verdigris must be removed from cable plugs. Keep all screw/nut connections tight.



## 6.0 Long live Reel Rotator

Regular inspection and the replacement of worn or defective parts in good time will prolong the life of the truck. "Prevention is better than repair", therefore ensure:

- That the battery is fully charged every time
- Correct usage
- Regular cleaning
- Periodic safety and service inspection (see the back page)
- For safety reasons please check the below every 3 month:
  - Tighten loose screw and nuts
  - Check that there are no cracks, fractures and deformations in the bearing construction
  - Wearing parts, such as brakes, wheels and bearings, are adjusted and exchanged continuously

### 6.1 Lubrication and hydraulic oil



Under normal operation conditions the Reel Rotator requires no lubrication. All ball bearings are sealed and lubricated for life, and moving parts have self-lubricating bearings or are treated with grease. The hydraulic system is filled with hydraulic oil of viscosity class

ISO VG 15.

An additive is added to the oil. The concentrate reduces friction and wear and protects against corrosion.

Pre-mixed hydraulic oil with additive is available from the dealer. The oil is suitable for use in the temperature range -10 to +50° C. A thinner oil is recommended for temperatures lower than -10° C (if necessary, contact your dealer).

## 6.0 Long live Reel Rotator

---

### 6.2 Oil change

#### Draining the oil:

1. Bring the unloaded reel carriage down to the lowest position (with fully open gripping arms).
  2. Most of the oil can be drained by loosening the hydraulic hose union in the bottom of the cylinder. Activate the hydraulic pump by pressure on the switch. The oil will run out.
  3. Take off the side plates.
  4. Take off the cables of the battery and push the battery box to the right side.
  5. The remaining oil can be drained from the oil tank by taking off the oil tank.
  6. Place the oil tank and the hydraulic hose again.
  7. Oil is filled in by removing the angular hose nipple from the tank.
  8. Oil quantity:  
The oil level is measured from the upper edge of the tank and downwards
- |                          | Oil quantity            |
|--------------------------|-------------------------|
| SELFRRRE & SELFSRRE 1750 | approx. 3,5 liter 30 mm |
9. Refit the angular hose nipple and bleed the system (see 6.5).

## 6.0 Long live Reel Rotator

---

### 6.3 Reel carriage adjustment

Two of the rollers on the reel carriage are mounted on eccentric pins, so that they can be adjusted. The adjustable rollers are at the top.

1. Loosen screw (pos. 91) (key width 5 mm).
2. Eccentric pins (pos. 56) (key width 8 mm) can now be turned to give the necessary reel carriage adjustment.
3. Adjustment must be made on both sides to ensure uniform loading of the rollers.

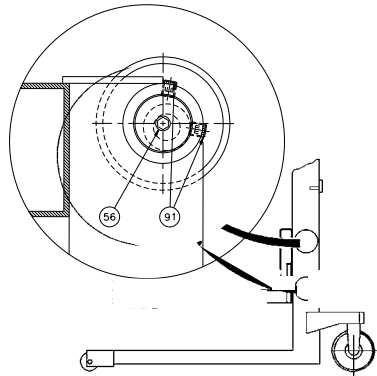

### 6.4 Adjustment of lifting chain

The chains shall be adjusted so that

- they lift equally
- they are equally tight
- The lifting movement has to stop in the cylinder, before the mast rolls touch the top stop.

After having adjusted the chains:

Check that the reel carriage is placed horizontally.

The nuts (pos. 18) are to be adjusted (nut M12, key width 19 mm).

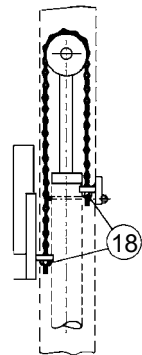

## 6.0 Long live Reel Rotator

---

### 6.5 The hydraulic pump and the gear motor

The hydraulic pump has a S3 "periodic intermittent duty" of 10%. This means that the pump in total is allowed to operate 1 minute for a period of 10 minutes.

**Note!** If the pump operates more than 10%, the motor will be damaged due to superheating.

#### Bleeding the hydraulic system

The reel carriage (without load) is raised and lowered to top and bottom position 2-3 times. Furthermore, the gripping arms are opened and closed 2-3 times.

#### Gear motor of the Reel Rotator

The gear motor has a "short time under constant load" of 10 minutes (S2= 10 minutes). This means that the motor is allowed to operate with the maximum load for 10 minutes. Hereafter it has to be cooled down to normal temperature.

**Note!** The motor will be damaged by superheating, if it operates for a longer time or if it is not cooled down.



### 6.6 Cleaning

When cleaning the Reel Rotator, do not direct the jet onto bearings, seals and electric components .

Cleaning of the plastic screen (polycarbonate)

The screen is to be washed with slightly warm water added a neutral cleaning material, and afterwards washed with clean water.

Use a soft sponge, a woollen cloth or a wash leather.



**Never use sharp objects or solvent cleaners when cleaning.**

## 6.0 Long live Reel Rotator



### 6.7 Adjustment of side play

(In the mast rolls of the right side of the reel carriage)

1. Screw (A) is loosened counter-clockwise, until resistance disappears.
2. Turn the screw clockwise, until resistance appears. The following 1.5 to 2.5 turns of the screw will be a tightening of the spring (C).
3. When a larger resistance appears, make 0.25 turn counterclockwise, and the counter nut (B) will be tightened.
4. Pump the carriage to the top position, and when lowering it has to slide to the bottom. If this is not the case, loosen screw A, make c. 0.5 turn counter-clockwise and repeat point 4.

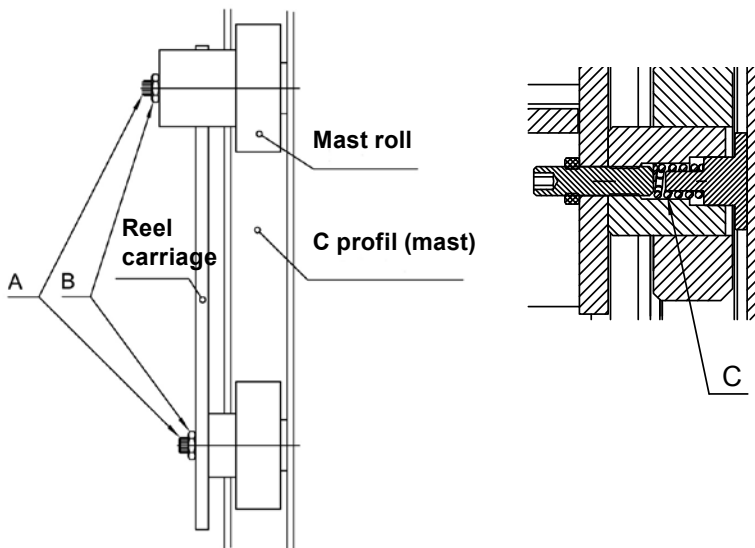



## 7.0 Adjusting the Reel Rotator

### 7.1 Tensioning the chains (only SELFRRE & SELFSRRE)

When the unloaded reel carriage can be tilted manually approx. 2 cm, measured at the rear carriage, the chains should be tensioned.

This is done by:

- 1) Removing the cover from the reel carriage.
- 2) Loosening the gear motor (A1)
- 3) Loosening chain wheel (B1)
- 4) Turning the nut (B2), so that the large chain is tensioned, until the slack is about 5 mm.
- 5) Tightening the chain wheel (B1)
- 6) Tightening the nuts for the gear motor (A2), so that the chain is tensioned, until the slack is about 2-3 mm. Tighten the nuts (A1) again.
- 7) Replace the cover.

#### NOTE!

Check the location of the inductive switch (see 7.2) and check that the large chain is tightened correctly in the whole rotation area after adjusting the chains.

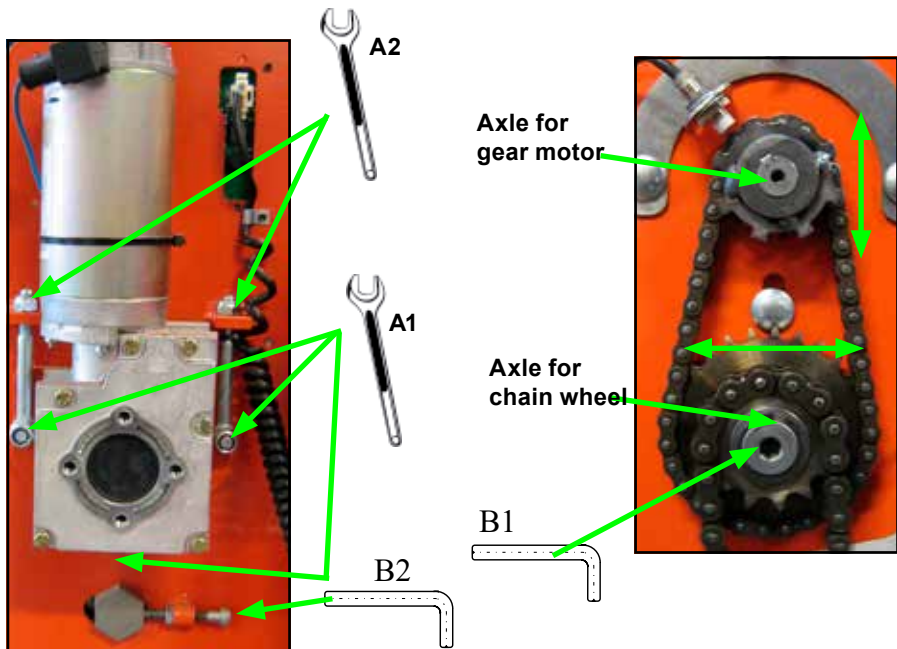

## 7.0 Adjusting the Reel Rotator

### 7.2 Adjusting the inductive switch (SELFRE/SELSRRE)

The location of the reel carriage is decided by two inductive switches.

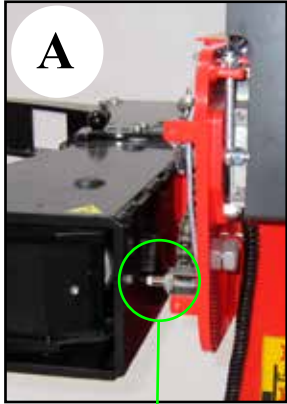

**A**

A) The inductive switch on the carriage indicates when the gripping arms are in position  $0^\circ$  (horizontal position).

When the reel carriage is in position  $0^\circ$ , the inductive switch has to be placed right above the indication pin on the thrust ring in a distance of 1-2 mm.

B) Inductive switch on the teeth of the little toothed wheel. The number of the impulses indicates the angle of the reel carriage.

The distance from the inductive switch to the tooth has to be 0-1 mm.

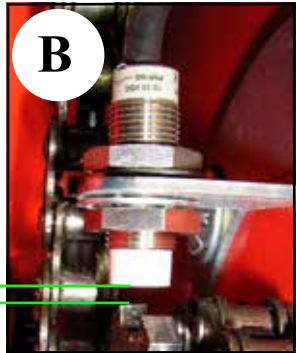

**B**

Inductive switch

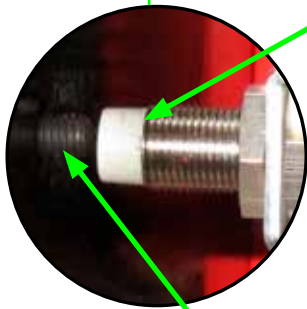

Indication bolt

### 7.3 Lubrication

#### Support bolts

To support the thrust ring, two support bolts are placed behind the ring.

The bolts must only just touch the ring, and the back of the ring has to be lubricated with grease, so that the bolts slide smoothly.

#### Chains

The chains of the Reel Rotator have to be lubricated at the yearly service check.





## 8.0 Fault location key

When the Reel Rotator is used every day, adjustments and the replacement of worn parts might be necessary.

Adjustments and minor repair can easily be made on the spot. Major repairs should, however, be carried through by the dealer who has a well-trained staff and the necessary special tools.

	<b>Before asking the dealer for assistance... ...try the fault location key!</b>
--	--

### SYMPTOMS AND OBSERVATIONS

- A** Pump does not run when the UP button is pressed\_\_\_\_\_
- B** Truck does not lift when the UP button is pressed\_\_\_\_\_
- C** Truck does not lift to max. height\_\_\_\_\_
- D** The reel carriage lowers after being raised\_\_\_\_\_
- E** The reel carriage does not not lower when DOWN button is pressed\_\_\_\_\_
- F** The reel carriage cannot be lowered fully\_\_\_\_\_
- G** Truck is unable to lift the max. load\_\_\_\_\_
- H** Truck lifts slowly\_\_\_\_\_
- I** The reel carriage does not lift horizontally\_\_\_\_\_

**Cause**

**Mending**

	Oil deficiency	See point 6.1/6.2
	Battery discharged	See separate instruction
	Fuse blown 10 Amp or 100 Amp	See point 5.1
	Cables defective	See point 5.2
	Max. load exceeded	See point 4.1
	Air in hydraulic system	See point 6.5
	Pressure relief valve incorrectly adjusted	Contact the dealer
	Leakage in hydraulic system Visible oil leakage	Contact the dealer
	Reel carriage needs adjustment	See point 6.3/6.4/6.7
	Solenoid or check valve defective	Contact the dealer
	Defective valves in pump	Contact the dealer
	Defective solenoid valve	Contact the dealer
<b>A</b>		
<b>B</b>		
<b>C</b>		
<b>D</b>		
<b>E</b>		
<b>F</b>		
<b>G</b>		
<b>H</b>		
<b>I</b>		

**If the problem cannot be solved by using the fault location key...**

**...please contact your dealer!**





## 9.0 Good service after purchase

### 9.1 Ordering spare parts

The correct spare parts are obtainable from your dealer.

When ordering, please state:

- Serial number of the product
- Type and width/length of the product
- Spare part no. Please find spare part no. on [www.logitrans.com](http://www.logitrans.com)

### 9.2 Warranty/Compensation

Spare parts delivered during the warranty period will be invoiced. A credit note will be sent immediately after we have received and tested the defective parts and found that the warranty conditions have been met.

### 9.3 Service and repair

You should be able to make adjustments and perform minor repairs on the spot. However, major repairs should be left to the dealer who has well-trained personnel and the necessary special tools.

### 9.4 Warranty

The warranty covers material and assembly defects which, subject to inspection by us or our representative, are deemed to be faults or deficiencies that prevent normal use of the parts concerned. Such affected parts shall be sent to your Logitrans dealer carriage paid within the warranty period in force at the time in question, together with a copy of the documentation for the service performed (B284 - see the back page). The warranty does not cover normal wear and adjustments. The warranty period is based on singleshift working.

#### **The warranty shall no longer apply if**

- the product has been used incorrectly,
- the product is used in environments for which it was not designed,
- the product has been overloaded,
- replacements of parts have been made incorrectly or original parts have not been used and consequential damages have arisen,
- the product is changed or accessories, not being approved by Logitrans, are used.
- it can not be proved that a qualified technician has performed the service check according to the requirements stated in the instruction manual (see the back page).

### 9.5 Liability exemption

The manufacturer accepts no responsibility for personal injury or material damage arising from deficiencies, defects or improper usage. The manufacturer accepts no responsibility for lost earnings, operating losses, lost time, lost profits or similar indirect losses incurred by the purchaser or a third party.





## **Periodic service and safety inspection**

Service inspection is required once each year, or at least for every 500 hours of operation.

Safety inspection should be performed by the dealer or other qualified persons at least once each year, unless local regulations state otherwise.

The inspections are to be performed on the basis of form no. B0342, and proved on form no. B284. Forms and instructions for the inspection are available at your dealer.

S996

SELFRR-EN

2/25042019