

LOGIFLEX SELF MINI / SELFS MINI

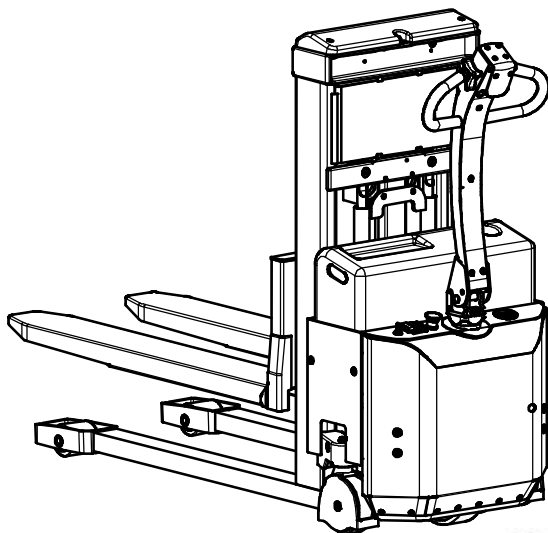
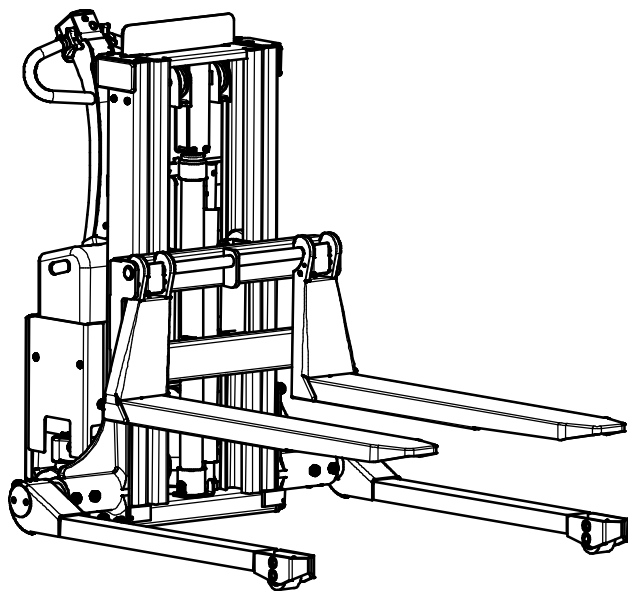

EU DECLARATION OF CONFORMANCE

Manufacturer: **Logitrans A/S**
Hillerupvej 35
DK-6760 Ribe
Denmark

It is hereby declared that:

Machine: Product group: Fully powered LOGIFLEX

 Type: SELF MINI / SELFS MINI

 Year of manufacture/
 Serial No.:

a) Has been manufactured in conformance with the stipulations of the:

- **Directive no. 2006/42/EC**
- **Directive no. 2004/108/EC**
- **Directive no. 2006/95/EC**

b) Has been manufactured in conformance with the stipulations of the standards:

- **EN ISO 3691-5**

Name: **Erling Pedersen**

Position: **Product manager**

Company: **Logitrans A/S**

Signature: 

Product type declaration of:
01.03.2010

Dealer:



Contents

1.0 Before the first lift...	4
2.0 Functions and identifications	5
3.0 How to operate the stacker	6
3.1 Handling of pallets	6
3.2 Handle functions	8
3.3 Emergency stop	9
3.4 Brake function	10
3.5 Personal safety	10
4.0 Optimum safety	11
4.1 Transport with load	12
4.2 Avoid overloads	13
5.0 There must be a current supply...	14
5.1 Fuses - replacement	14
5.2 Wiring connections	14
6.0 Long live the Logiflex Mini	15
6.1 Lubrication and hydraulic oil	15
6.2 Oil change	16
6.3 Hydraulic pump	17
6.4 Cleaning	17
6.5 Fork adjustment	18
6.6 Adjustment of lifting chain	18
6.7 Adjustment of side play	19
7.0 Fault location key	20
7.1 Remedy	22
8.0 Good service after purchase	24
8.1 Ordering spare parts	24
8.2 Warranty/Compensation	24
8.3 Service and repair	24
8.4 Warranty	24
8.5 Liability exemption	24



1.0 Before the first lift...

The **Logiflex Mini** is manufactured in accordance with safety directives.

Among the subjects dealt with in this **Instruction Manual** are:



- Proper application
- Physical limitations of the product
- Risks with improper use

Therefore please read this **Instruction Manual** carefully!

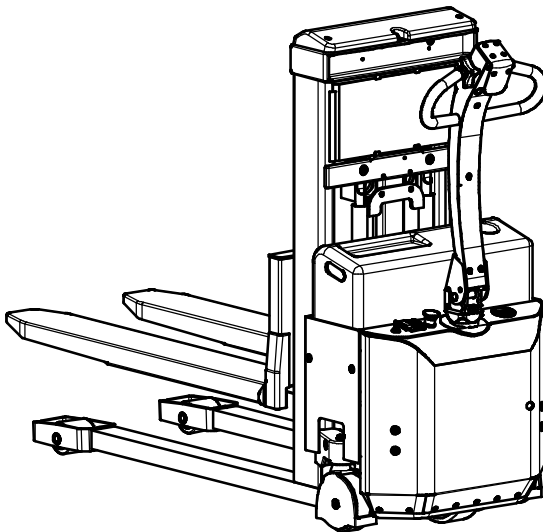



2.0 Functions and identifications

1. Safety Switch
2. Horn
3. Lift/Lower
4. Forward/Reverse
5. Multiflex Function
6. Handle
7. Battery indicator / hours counter
8. Emergency Stop
9. Ignition Key
10. Charger Plug
11. Charging Lamps (built-in charger)

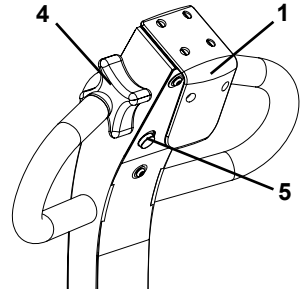
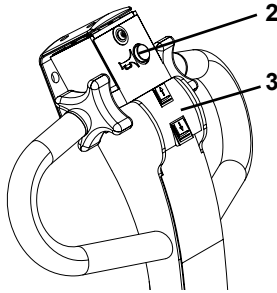

Identification

Battery label,
(below the battery cover).

Name plate, serial number

Truck number, stamped in
chassis behind the rear cover.

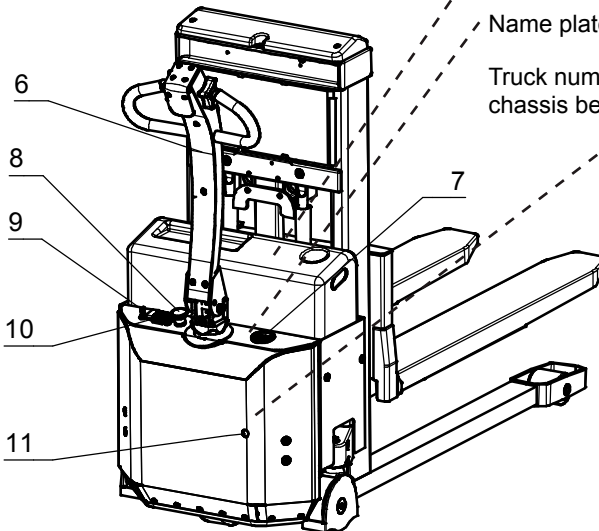



3.0 How to operate the stacker

3.1 Handling of pallets

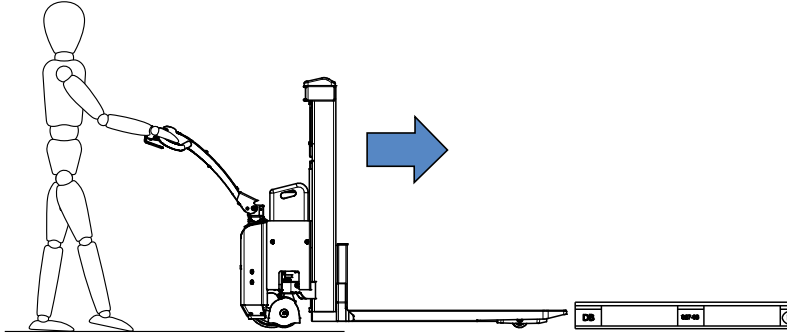

For proper operation,
stand behind the handle!

The forks will lift 330 mm before
the telescopic mast begins to
extend.

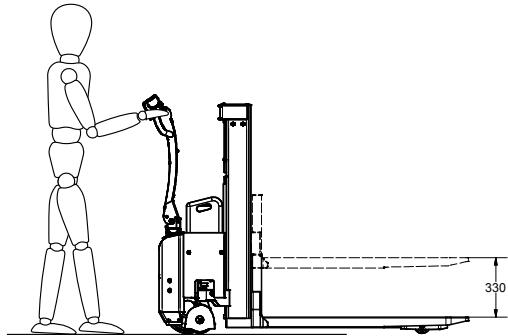

SELS MINI

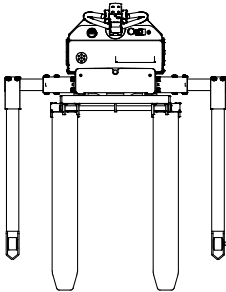

When handling closed pallets...
- use straddle Logiflex Mini.

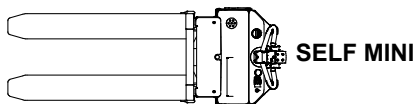
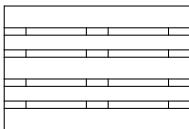

3.0 How to operate the stacker

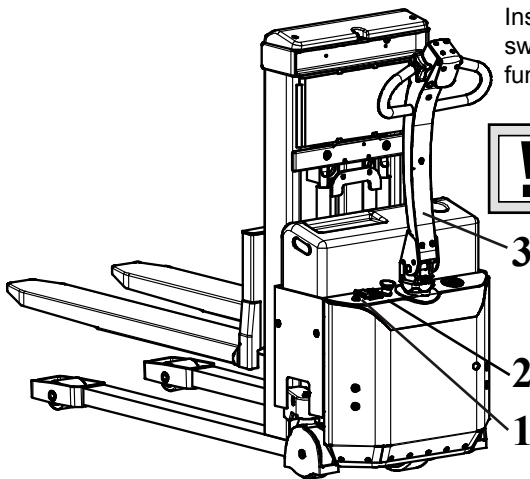

Insert key (1) and turn clockwise to switch on control current ready for function activation.

! Note!!! Emergency stop (2) must not be activated.

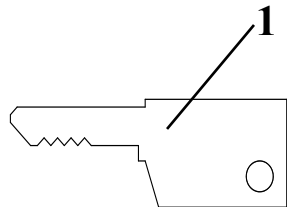

The control functions of the stacker are located in the handle (3).
- The functions are dependent on the positions of the handle!

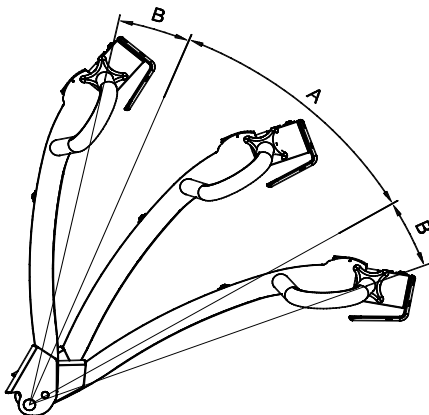

Position A: Drive position
Drive current on
Brake deactivated

**Position B: Stop/Brake/
Emergency Stop**
Drive current off
Brake activated

3.0 How to operate the stacker

3.2 Handle functions

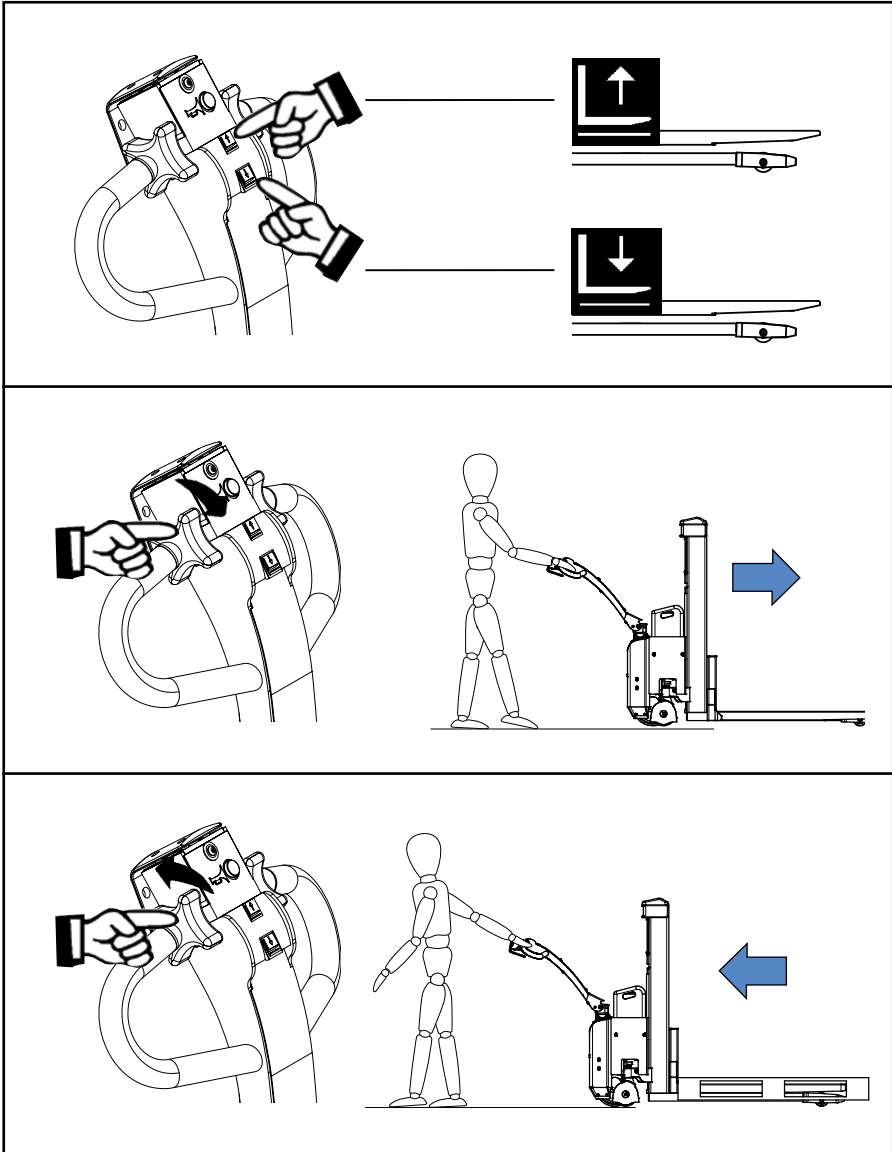

3.0 How to operate the stacker

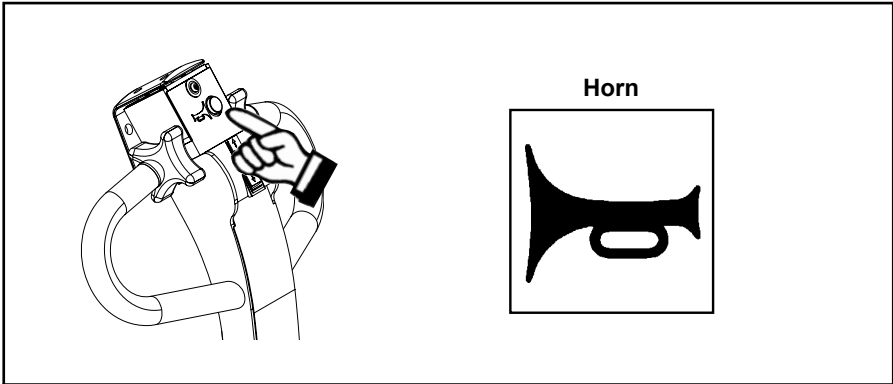

Horn

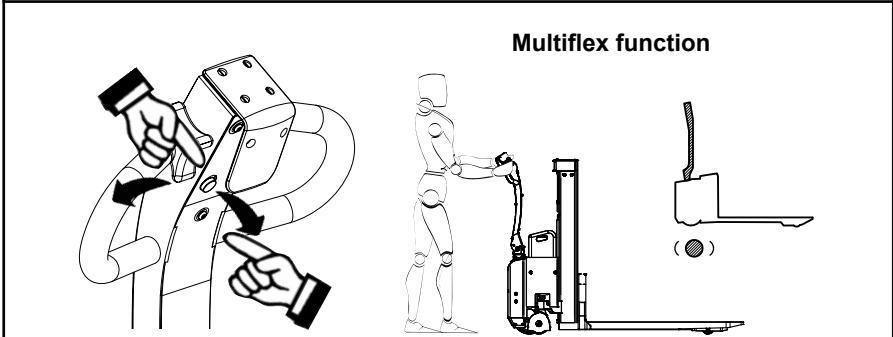

Multiflex function

Multiflex function

- This function makes it possible to drive the stacker, even though the handle is in its upright, braked position
- The function requires two-handed operation, i.e. it must be performed deliberately
- The function facilitates manoeuvring in confined areas.

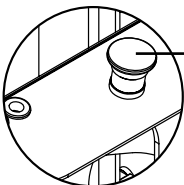

3.3 Emergency stop

The product has an emergency stop. When activating the emergency stop, the main current supply is switched off.

- The movement of the forks stops immediately
- Driving with the truck stops immediately.

3.0 How to operate the stacker

3.4 Brake function

A: Position for driving

B: Position for braking
See multiflex function
for driving in B-position
(see paragraph 3.2)

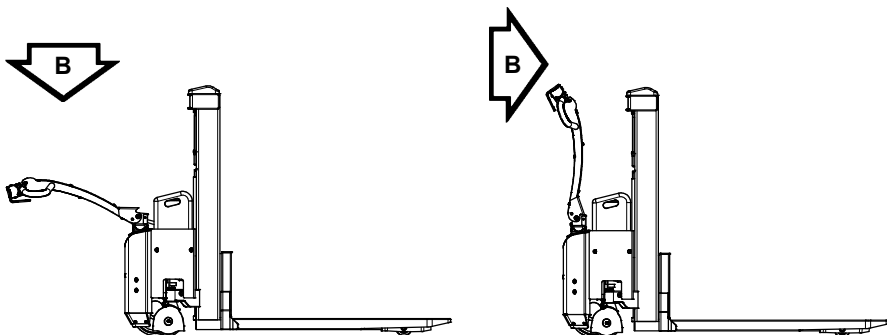
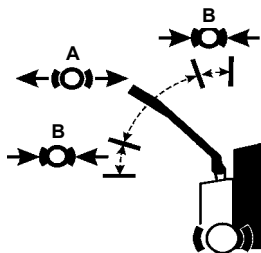

3.5 Personal safety

The safety switch on the end of the handle ensures that the operator cannot be trapped when the stacker is reversed.

When the safety switch is activated, the stacker will change direction and move forwards.

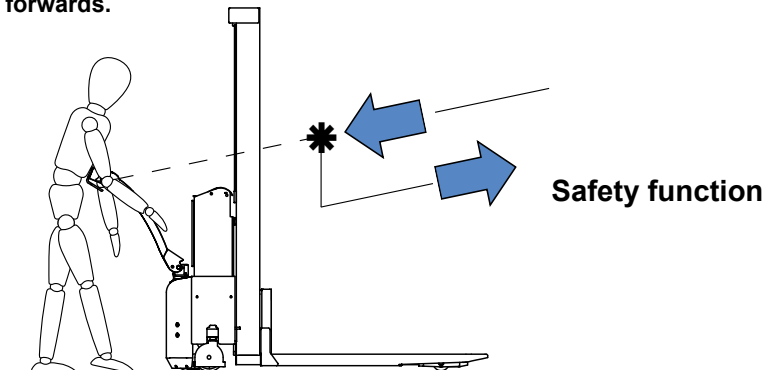



4.0 Optimum safety



ATTENTION
Moving parts

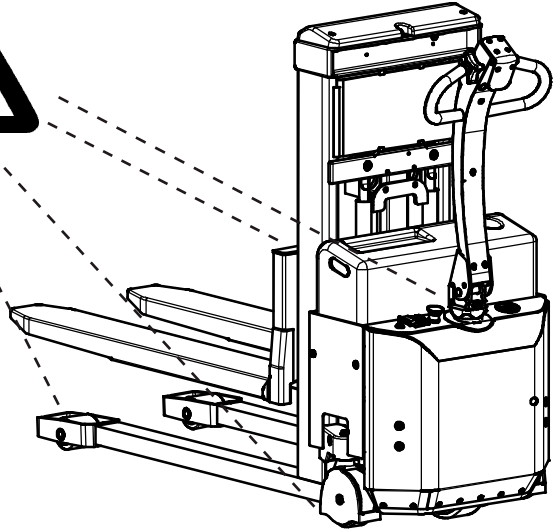

Safety regulations

- Never walk under a raised load!
- Before lowering the forks, make certain that no foreign elements can hinder the free lowering of the forks.
- Logiflex Mini is designed for use on an even and level floor.
- During transport the forks shall be raised as little as possible.
- Transport with raised forks should be made over the shortest possible distances and at low speed.
- Check that the chains lift equally. They shall be equally tight when the forks are loaded
- Chains and chain bolts must not be damaged.
Chains that have become permanently stretched (max. 2% of original length) must be scrapped.



4.0 Optimum safety

4.1 Transport with load

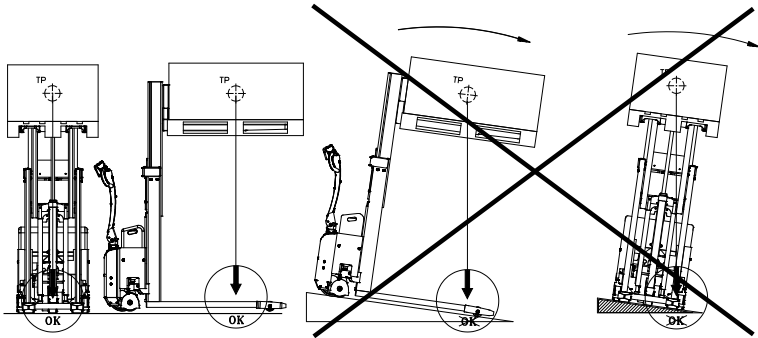

The Logiflex Mini is designed for use on even and level floor. During transport the forks shall be raised as little as possible. Transport with raised forks should be made over the shortest possible distances and at low speed.

4.0 Optimal sikkerhed

4.2 Avoid overloads

The maximum load must not be exceeded.

Remember, the stacker is designed for evenly distributed load; - goods on pallets etc.

- If the forks are point-loaded on one side, there is a risk of bending.

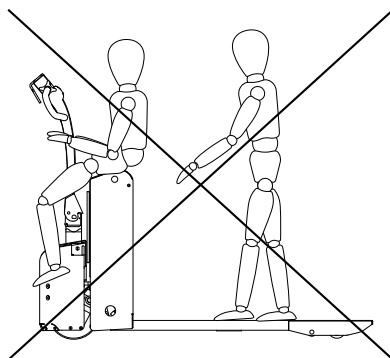
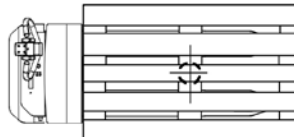

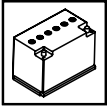

5.0 There must be a current supply...

5.1 Fuses - replacement

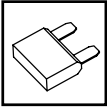

There are 4 fuses in the electrical circuit, located behind the plate with this pictogram.



- G) 50 Amp fuse for driving motor
- I) 60 Amp fuse for lifting motor
- J) 15 Amp fuse (built-in Soneil charger)
- F) 5 Amp fuse in the control current circuit

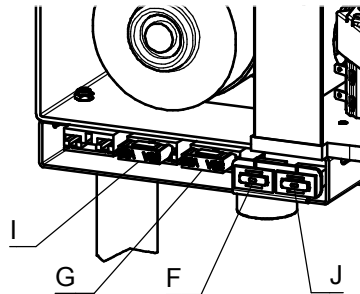

Replacement:

The old fuse is to be removed and replaced by a new one of the same size.

Find out why the fuses blow!

5.2 Wiring connections

Many operational disturbances are caused by bad connections in the electrical circuit. Make sure that the connections are in order.

Check connections regularly for damage at insulating caps or bad connections at plugs etc. Verdigris must be removed from cable plugs. Keep all screw/nut connection tight.



6.0 Long live the Logiflex Mini

Regular inspection and the replacement of worn or defective parts in good time will prolong the life of the Logiflex Mini. "Prevention is better than repair", therefore ensure:

- Check battery every 14 cycles
- Correct usage
- Regular cleaning
- Periodic safety and service inspection
- For safety reasons please check the below every 3 month:
 - Tighten loose screw and nuts
 - Check that there are no cracks, fractures and deformations in the bearing construction
 - Wearing parts, such as brakes, wheels and bearings, are adjusted and exchanged continuously

6.1 Lubrication and hydraulic oil



Under normal operation conditions the Logiflex Mini requires no lubrication. All ball bearings are sealed and lubricated for life, and moving parts have self-lubricating bearings or are treated with grease.

The hydraulic system is filled with hydraulic oil of viscosity class ISO VG 15. An additive is added to the oil. The concentrate reduces friction and wear and protects against corrosion.

Pre-mixed hydraulic oil with additive is available from the dealer.

To ensure that the cylinder pipe is lubricated and thereby protected against corrosion, it is important to lift the forks to top position frequently. The oil is suitable for use in the temperature range -10° to $+50^{\circ}$ C. A special oil is recommended for temperatures lower than -10° C (if necessary, contact your dealer).

6.0 Long live the Logiflex Mini

6.2 Oil change

Draining the oil:

1. Bring the unloaded forks down to the lowest position.
2. Most of the oil can be drained by loosening the hydraulic hose union in the bottom of the cylinder. Activate the hydraulic pump by pressure on the switch. The oil will run out.
3. Take off the cables of the battery. Remove the batteries and the plate below.
4. The remaining oil can be drained from the oil tank by taking off the pump and turning the pump, so that the filling hole is turned upside down.
5. Place the hydraulic hose again.
6. Fill in the oil through the filling hole on the tank.

7. Oil quantity:

SELF Mini	approx. 3,0	Litre
-----------	-------------	-------

8. Refit the connecting piece, the overflow hose and bleed the system (see paragraph 6.3).

6.0 Long live the Logiflex Mini

6.3 Hydraulic pump

The hydraulic pump has a S3 “periodic intermittent duty” of 10%, meaning that the pump is allowed to operate 1 minute in a period of 10 minutes.

Note! If the pump operates more than 10%, the motor will be damaged due to superheating.

Bleeding the hydraulic system

With a load of 50-100 kg, the forks must be raised and lowered to top and bottom position 2-3 times.

6.4 Cleaning



When cleaning the Logiflex Mini, do not direct the jet onto bearings and seals. Otherwise the grease will be washed out and the life of the equipment shortened.

Cleaning of the plastic screen (polycarbonate)

The screen is to be washed with slightly warm water added a neutral cleaning material, and afterwards washed with clean water.

Use a soft sponge, a wollen cloth or a wash leather.



**Never use sharp objects
or solvent cleaners when cleaning.**

6.0 Long live the Logiflex Mini

6.5 Fork adjustment

Two of the rollers on the fork bracket are fitted on eccentric pins so that they can be adjusted. The adjustable rollers are uppermost.

1. Loosen screw (pos. 91) (key width 5 mm).
2. Eccentric pin (pos. 56) (key width 8 mm) can now be turned to give the necessary fork adjustment.
3. Adjustment must be made on both sides to ensure uniform loading of the rollers.

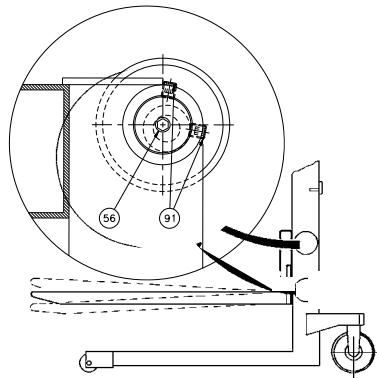

6.6 Adjustment of lifting chain

The chains shall be adjusted so that

- they lift equally
- they are equally tight
- The lifting has to stop in the cylinder, before the mast rolls touch the top stop.

After adjusting the top stop, check the following:

- a: Fork bracket (fixed):
The forks are not allowed to touch the wheels
- b: Fork carriage (adjustable):
The forks are to be kept clear of the floor.

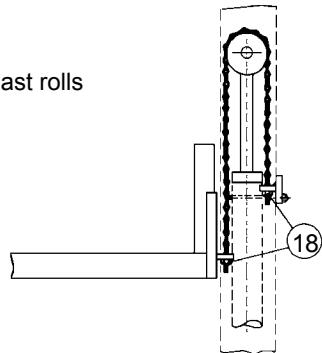

The nuts (pos. 18) are to be adjusted (nut M12, key width 19 mm).

6.0 Long live the Logiflex Mini

6.7 Adjustment of side play (In the mast rolls on the fork bracket)

- 1: Loosen nut (B). Screw (A) is loosened counter-clockwise, until resistance disappears.
- 2: Turn the screw clockwise, until resistance appears.
The following 1.5 to 2.5 turns of the screw will be a tightening of the spring (C).
- 3: When a larger resistance appears, make 0.25 turn counter-clockwise, and the counter nut (B) will be tightened.
- 4: Pump the forks to the top position. When lowering they have to slide to the bottom. If this is not the case, loosen screw A, make c. 0.5 turn counter-clockwise and repeat point 4.

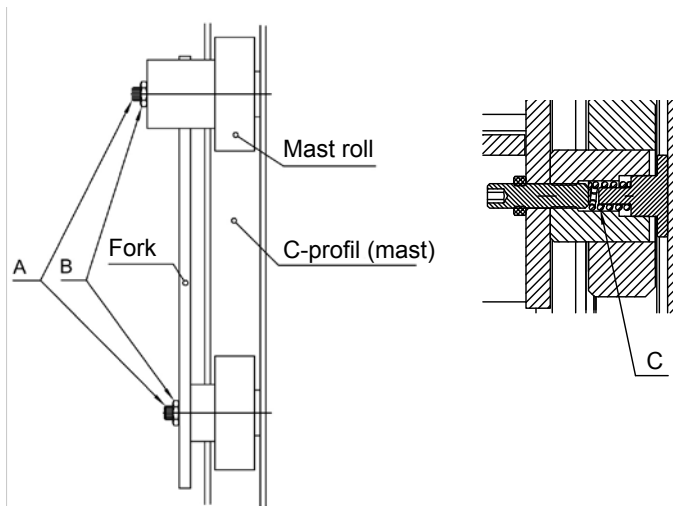



7.0 Fault location key

When the Logiflex Mini is used every day, adjustments and the replacement of worn parts might be necessary.

Adjustments and minor repairs can easily be made on the spot. Major repairs should, however, be carried through by the dealer who has a well-trained staff and the necessary special tools.



**Before asking the dealer for assistance...
...try the fault location key!**

Symptoms and observations

- A** The stacker does not drive when the handle is tilted and drive grip turned!
- - no click can be heard from relays when the handle is tilted _ _ _ _ _
- - no click can be heard when the multiflex button is activated _ _ _ _ _
- - the motor makes a humming noise _ _ _ _ _
- B** The stacker drives slowly _ _ _ _ _
- C** The stacker brakes when drive grip is released (handle tilted) _ _ _ _ _
- D** The stacker does not brake when handle is tilted to upper or lower position _ _ _ _ _
- E** The stacker brakes too little/too much _ _ _ _ _
- F** Forks do not lift when "UP" is pressed _ _ _ _ _
- G** No click can be heard when "UP" is pressed _ _ _ _ _
- H** Forks lift only a little/not to max. height when "UP" is pressed _ _ _ _ _
- I** Forks do not sink when "DOWN" is pressed _ _ _ _ _
- J** Forks sink slowly _ _ _ _ _
- K** The battery is not charged (no light in charging lamp) _ _ _ _ _
- L** Error 1.4 _ _ _ _ _

Cause

Mending

	Cause	Mending
	Inadequate power supply	1)
	Battery discharged (error 4.2)	2)
	Fault in on/off switch	3)
	Fault in control current circuit	4)
	Fault in main/power current circuit	5)
	Too little current on battery (error 4.2)	6)
	No current on brake	7)
	Brake needs adjusting	8)
	Insufficient oil in tank. Load too heavy. Safety valve is set wrongly.	9)
	No current on solenoid valve.	10)
	Oil circuit leakage	11)
	Fault in charging circuit	12)
	Forward/Reverse knob activated before handle is in pos. A	13)
	<p>If the problem cannot be solved by using the fault location key...</p> <p>...read the error code, see paragraph 7.1 and contact the dealer!</p>	

A

- — ● — ● — ● — ● — ●

- — ● — ● — ● — ● — ●

- — ● — — — — — ● — ●

B — ● — — — — — ● — ●

C — — — — — ● — ●

D — — — — — ● — ●

E — — — — — ● — ●

F — ● — — — — — ● — — — — ●

G — ● — ● — — — — — ●

H — ● — — — — — ● — — — — ●

I — — — — — ● — — — — — ●

J — — — — — — — — — — — ●

K — — — — — — — — — — — ●

L — — — — — — — — — — — ●



7.0 Fault location key

7.1 Remedy

- 1) Check that the key (A) is turned clockwise and that emergency stop (B) is not activated.
- 2) Charge battery - (see separate instruction manual for battery and charger).
Access to the battery is achieved by removing the battery lid (C).
 - If necessary, check the liquid level in battery cells.
 - The remaining capacity of the battery can be checked with an acidometer.
- 3) Check switch (D). Check cable connections on switch.
- 4) Check control current fuse (F): 5 A
 - If the fuse is intact and the truck does not drive, contact the dealer.
- 5) Check main fuse for driving motor (G).
Check cable connections on drive motor and pump motor.
If no fault can be found and the truck does not drive, contact the dealer.
- 6) Check the wire connections between the battery cells, and to the battery. In case of verdigris on the connections, these are to be cleaned.
Check that all cable connections are fixed.
- 7) Check the wiring loom on the side of the wheel motor. Check that the brake is activated when the handle is activated. Check that the brake is adjusted correctly. If no fault can be found and the truck still brakes, please contact the dealer.
- 8) Brake needs adjustment - please contact the dealer.
- 9) Fill in oil in the tank (H).
Max. load given on name plate. If the truck can not lift the load, given on the name plate, contact the dealer.
- 10) Check the fuse for the pump motor: 60 A (I)
 - If the fuse is intact and the stacker does not lift, please contact the dealer.
- 11) Locate the oil leak and contact the dealer.
To localise the leak it is necessary to remove the rear cover (E).
- 12) Check the fuse for the charger (J)
- 13) Place the handle in drive position before turning forward/reverse knob.

7.0 Fault location key

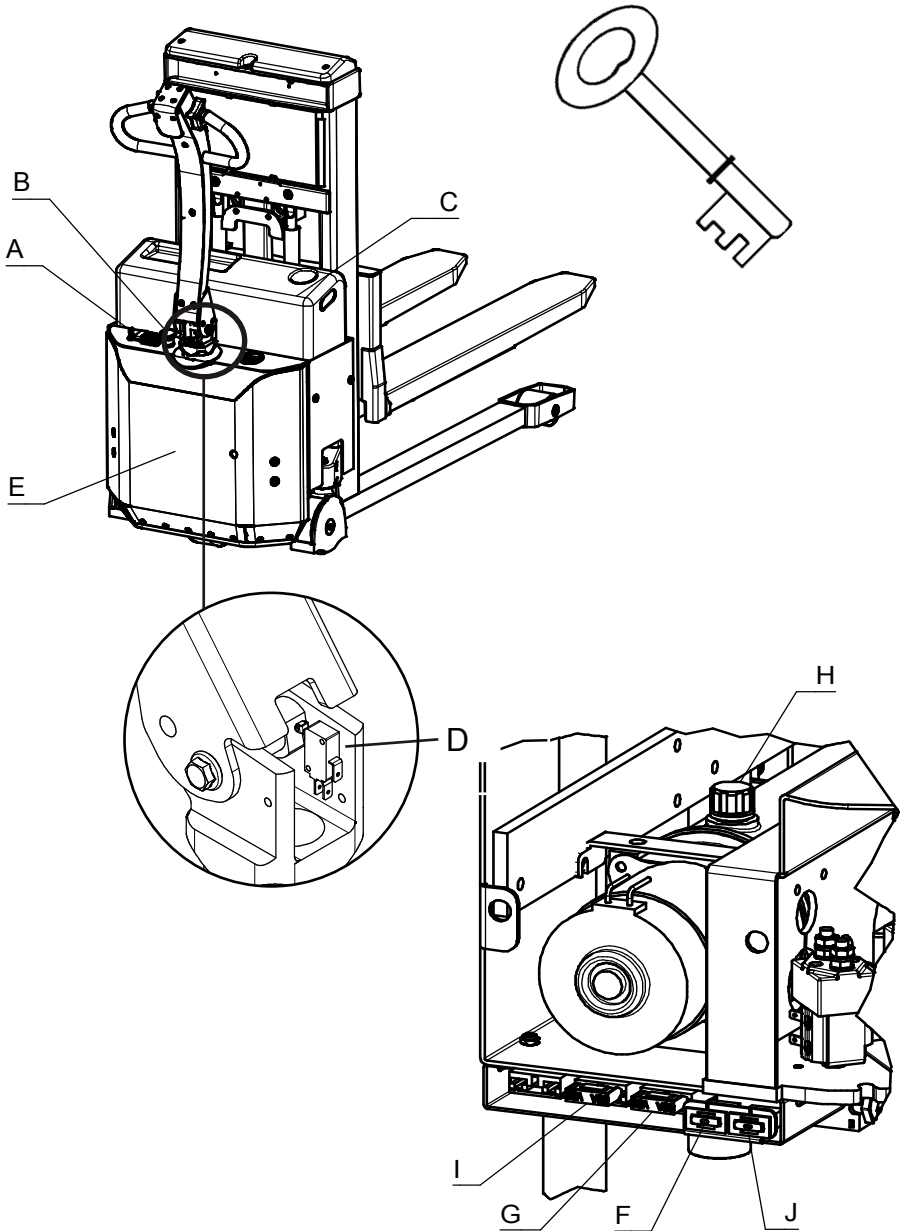



8.0 Good service after purchase

8.1 Ordering spare parts

The correct spare parts are obtainable from your dealer.

When ordering, please state:

- Serial number of the product
- Type and width/length of the product
- Spare part no. Please find spare part no. on **www.logitrans.com**.

8.2 Warranty/Compensation

Spare parts delivered during the warranty period will be invoiced. A credit note will be sent immediately after we have received and tested the defective parts and found that the warranty conditions have been met.

8.3 Service and repair

You should be able to make adjustments and perform minor repairs on the spot. However, major repairs should be left to the dealer who has well-trained personnel and the necessary special tools.

8.4 Warranty

The warranty covers material and assembly defects which, subject to inspection by us or our representative, are deemed to be faults or deficiencies that prevent normal use of the parts concerned. Such affected parts shall be sent to your Logitrans dealer carriage paid within the warranty period in force at the time in question, together with a copy of the documentation for the service performed (B284 - see the back page). The warranty does not cover normal wear and adjustments. The warranty period is based on singleshift working.

The warranty shall no longer apply if

- the product has been used incorrectly,
- the product is used in environments for which it was not designed,
- the product has been overloaded,
- replacements of parts have been made incorrectly or original parts have not been used and consequential damages have arisen,
- if the product is changed or accessories, not being approved by Logitrans, are used.
- it can not be proved that a qualified technician has performed the service check according to the requirements stated in the instruction manual (see the back page).

8.5 Liability exemption

The manufacturer accepts no responsibility for personal injury or material damage arising from deficiencies, defects or improper usage. The manufacturer accepts no responsibility for lost earnings, operating losses, lost time, lost profits or similar indirect losses incurred by the purchaser or a third party.

Periodic service check

Service check is required once each year, or at least for every 250 hours of operation

The service check is to be performed on the basis of form no. B280 and proved on form no. B284. Forms and instructions for the service check are available at your dealer.

Periodic safety inspection

Safety inspection should be performed by the dealer or other qualified persons at least once each year, unless local regulations state otherwise.

The safety inspection to be performed on the basis of form no. B278 and proved on form no. B284. Forms and instructions for the safety inspection are available at your dealer.

S 876

Logiflex_Mini-ENG
01032010